

Installation Information

LIPS[®] P100 CYLINDER – LINEAR POSITION SENSOR

Output Option	Output Description:	Supply Voltage: V _s (tolerance)	Load resistance: (include leads for 4 to 20mA O/Ps)
A	0.5 - 4.5V (ratiometric with supply)	+5V (4.5 - 5.5V)	≥ 5kΩ
B	±5V	±15V nom. (±9 - 28V)	≥ 5kΩ
C	0.5 - 9.5V	+24V nom. (13 - 28V)	≥ 5kΩ
D	±10V	±15V nom. (±13.5 - 28V)	≥ 5kΩ
E	4 - 20mA 2 wire Current Loop	+24V nom. (18 - 28V)	≈ 0 - 300Ω max. @24V ~ 1.2 to 6V across 300Ω {R _L max. = (V _s - 18) / 20 ⁻³ }
F	4 - 20mA 3 wire Sink	+24V nom. (13 - 28V)	≈ 0 - 950Ω max. @24V ~ 3.8 to 19V across 950Ω {R _L max. = (V _s - 5) / 20 ⁻³ }
G	0.5 - 4.5V	+24V nom. (9 - 28V)	≥ 5kΩ
H	4 - 20mA 3 wire Source	+24V nom. (13 - 28V)	≈ 0 - 300Ω max. ~ 1.2 to 6V across 300Ω

Not all output options available - see product datasheet for full options list

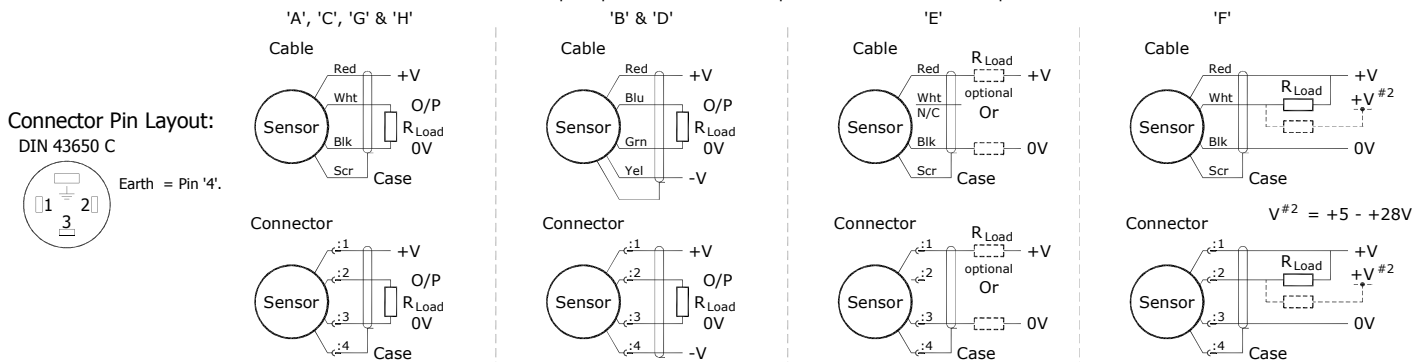

Gain and Offset Adjustment: (Where accessible - Typically ± 10% Min available)

To adjust the gain or offset use a small potentiometer adjuster or screwdriver 2mm across. Do not apply too much force on the potentiometers.

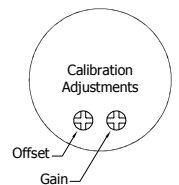

Mechanical Mounting: Via mounting thread, maximum tightening torque: 100Nm. See drawing P100-15, Installation Details Mounting Threads & Seals. An O ring seal is provided, size BS908 for M20 & 3/4 UNF thread or 14.3 x 2.4 for M18 thread. Install the target tube using the flange provided or fix directly into the piston rod using adhesive for instance, the end of the target tube can be proud or flush with the piston end face as required.

Output Characteristic: Target position at start of normal travel is 36.0 mm from seal face. The output increases as the target is moved away from the sensor body, the calibrated stroke is between 5 mm and 800 mm.

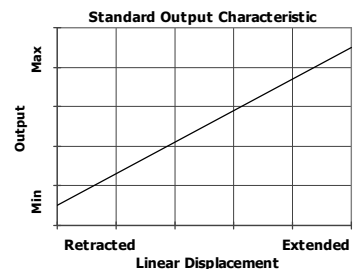

Incorrect Connection Protection levels:-

- A **Not protected** – the sensor is **not** protected against either reverse polarity or over-voltage. The risk of damage should be minimal where the supply current is limited to less than 50mA.
- B & D Supply leads diode protected. Output must not be taken outside ± 12V.
- C & G Supply leads diode protected. Output must not be taken outside 0 to 12V.
- E, F & H Protected against any misconnection within the rated voltage.