

LIPS[®] P103 SHORT STROKE LINEAR POSITION SENSOR

Position feedback for industrial and scientific applications

- Non-contacting inductive technology to eliminate wear
- Travel set to customer's requirement
- Short body length
- High durability and reliability
- High accuracy and stability
- Sealing to IP65/IP67 as required



As a leading designer and manufacturer of linear, rotary, tilt and intrinsically safe position sensors, Positek[®] has the expertise to supply a sensor to suit a wide variety of applications.

Our P103 LIPS[®] (Linear Inductive Position Sensor) is an affordable, durable, accurate position sensor designed for a wide range of industrial applications. It is particularly suitable for OEMs seeking good sensor performance in situations where a short-bodied sensor is needed and cost is important. The unit is compact and space-efficient, being responsive along almost its entire length, and like all Positek[®] sensors provides a linear output proportional to displacement. Each unit is supplied with the output calibrated to the travel required by the customer, from 2 to 50mm and with full EMC protection built in.

Overall performance, repeatability and stability are outstanding over a wide temperature range.

The sensor has a rugged stainless steel body and plunger. It is easy to install and set up, mounting options include flange and body clamps. The plunger can be supplied free or captive, with female M4 thread, or spring-loaded with a ball end. The P103 also offers a wide range of mechanical and electrical options, environmental sealing is to IP65 or IP67 depending on selected cable or connector options.

SPECIFICATION

DIMENSIONS

For full mechanical details see drawing P103-11

Independent linearity	< ± 0.25% @ 20°C
Temperature coefficients	< ± 0.01%/°C Gain & < ± 0.01%FS/°C Offset
Frequency response	> 10 kHz (-3dB) > 300 Hz (-3dB) 2 wire 4 to 20 mA
Resolution	Infinite
Noise	< 0.02% FSO
Environmental Temperature Limits	
Operating	-40 to +125°C standard -20 to +85°C buffered
Storage	-40 to +125°C
Sealing	IP65/IP67 depending on connector / cable option
EMC Performance	EN 61000-6-2, EN 61000-6-3
Vibration	IEC 68-2-6: 10g
Shock	IEC 68-2-29: 40 g
MTBF	350,000 hrs 40°C Gf
Drawing List	
P103-11	Sensor Outline
<i>Drawings, in AutoCAD[®] dwg or dxf format, available on request.</i>	

Do you need a position sensor made to order to suit a particular installation requirement or specification? We'll be happy to modify any of our designs to suit your needs - please contact us with your requirements.

For further information please contact:

www.positek.com sales@positek.com

Tel: +44(0)1242 820027 fax: +44(0)1242 820615

Positek Ltd, Andoversford Industrial Estate, Cheltenham GL54 4LB U.K.

LIPS® P103 SHORT STROKE LINEAR POSITION SENSOR

Position feedback for industrial and scientific applications

How Positek's PIPS® technology eliminates wear for longer life

Positek's PIPS® technology (Positek Inductive Position Sensor) is a major advance in displacement sensor design. PIPS®-based displacement transducers have the simplicity of a potentiometer with the life of an LVDT/RVDT.

PIPS® technology combines the best in fundamental inductive principles with advanced micro-electronic integrated circuit technology. A PIPS® sensor, based on simple inductive coils using Positek's ASIC control technology, directly measures absolute position giving a DC analogue output signal. Because there is no contact between moving electrical components, reliability is high and wear is eliminated for an exceptionally long life.

PIPS® overcomes the drawbacks of LVDT technology – bulky coils, poor length-to-stroke ratio and the need for special magnetic materials. It requires no separate signal conditioning.

Our LIPS® range are linear sensors, while RIPS® are rotary units and TIPS® are for detecting tilt position. Ask us for a full technical explanation of PIPS® technology.

We also offer a range of ATEX-qualified intrinsically-safe sensors.

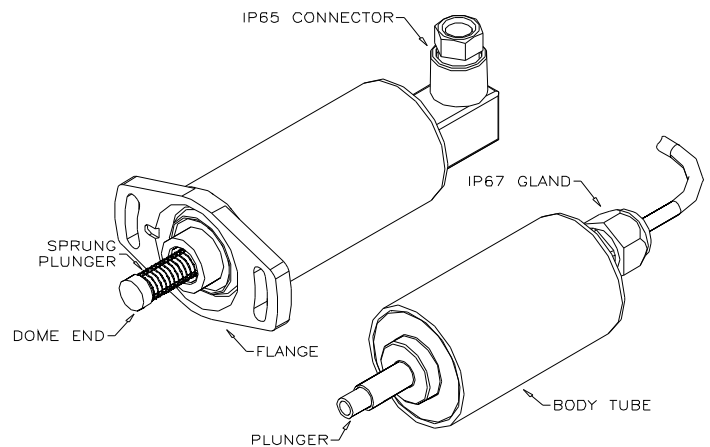

TABLE OF OPTIONS

MEASUREMENT RANGE: Factory-set to any length from 2 to 50 mm in increments of 1mm.

ELECTRICAL INTERFACE OPTIONS

OUTPUT SIGNAL	SUPPLY INPUT	OUTPUT LOAD
Standard:		
0.5-4.5V dc ratiometric	+5V dc nom. ± 0.5V.	5kΩ min.
Buffered:		
0.5-4.5V dc	+24V dc nom. + 9-28V.	5kΩ min.
±5V dc	±15V dc nom. ± 9-28V.	5kΩ min.
0.5-9.5V dc	+24V dc nom. + 13-28V.	5kΩ min.
±10V dc	±15 V dc nom. ± 13.5-28V.	5kΩ min.
Supply Current	10mA typical, 20mA maximum.	
4-20mA (2 wire)	+24 V dc nom. + 18-28V.	300Ω @ 24V.
(3 wire sink)	+24 V dc nom. + 13-28V.	950Ω @ 24V.
(3 wire source)	+24 V dc nom. + 13-28V.	300Ω max.

Option for output 'zero' and 'span' adjustment available.

CONNECTOR/CABLE OPTIONS

Connector - Hirschmann GD series IP65
 Cable with M12 gland or short gland IP67
 Cable length >50cm – please specify length in cm

MOUNTING OPTIONS

Flange, Body Tube Clamp.

PUSH ROD OPTIONS – standard retained with M4x0.7 female thread
 Sprung loaded (spring supplied loose), Dome end (sprung loaded) or Free.

