

Datasheet

Compact laser diode module - iFLEX-Q3

The iFLEX-Q3™ is a compact laser diode module with a small form laser head and remote electronics module. The laser is mode-hop free and wavelength stabilized as a direct result of active temperature control. A closed loop control provides long term power stability and an ability to monitor the power via an external output signal.

The diode laser system is guaranteed for long lifetime and delivers exceptional power stability with low amplitude noise. All models feature an interlock and output diagnostics for laser current and temperature as standard.

All lasers feature diffraction limited collimated output beams with elliptical profiles as standard. Customized options for circular beam profiles are available. A feature of this laser is low dynamic pointing error and precise static beam alignment tolerances.

The iFLEX-Q3 is compatible with a number of commercially available imaging software packages such as Olympus cell[^]R™, MetaMorph® and μManager and a number of add-on interfaces ensure a complete solution for all microscope systems.

The laser has been designed for integrated measurement applications where a small optical head is required to deliver an exceptionally stable and precise laser beam. The highly polarized nature of the beam makes the laser ideal for scatter and reflection based measurement such as ellipsometry. All models deliver exceptional brightness and reliability for optical media inspection applications.

Some of the product features include:

- Available in powers up to 100mW
- Available wavelengths are 375, 405, 445, 473, 488, 515, 640, 660, 670, 780, 830nm
- Compact laser head footprint for limited space applications
- Customizable umbilical connector cable lengths
- Modulation capability on request
- OEM versions available upon request



Technical Specifications

Lasers												units	
Wavelength	375 ^a	405 ^b	445 ^a	473 ^a	488 ^b	515 ^b	640 ^c	660 ^c	670 ^a	780 ^d	830 ^d	nm	
Output power	15	50, 85	40	10	50	20	35, 100	60	8	60	100	mW	
Centre wavelengths												± 5	nm
Optical power stability												< 2% (over 8 hours)	-
Optical Noise (20Hz to 2MHz) rms*												< 0.1	%
Optical Noise (20Hz to 2MHz) pk to pk*												< 1	%
Laser beam parameters													
Polarization ratio												≤ -27	dB
Beam diameter												^a 2.2 (vertical) x 0.7 (horizontal) ^b 2.1 (vertical) x 0.9 (horizontal) ^c 1.6 (vertical) x 0.9 (horizontal) ^d 2.0 (vertical) x 0.9 (horizontal)	mm
M squared												≤ 1.2*	-
Beam divergence												Diffraction limited	-
Beam position												≤ ±0.25	mm
Beam angle												≤ ±0.5	mrad
Pointing stability												≤ 5μrad/ °C	-
Mechanical, electrical and environmental													
Dimensions (laser head)												36 x 36 x 90	mm
Power supply (laser)												12 V DC, 0.5A	-
Power supply (TE controller)												5 V DC, 3A max, 1A running	-
Max. base plate temperature												+ 40	°C
Max. heat dissipation												12.5	W
Storage temperature												10 to 50	°C
Operating pressure												Atmospheric	-
Operating temperature												10 to 40	°C
Operating humidity												Non-condensing	-

*Model Specific - contact Qioptiq for clarification

Note: OEM versions available please call

Laser head

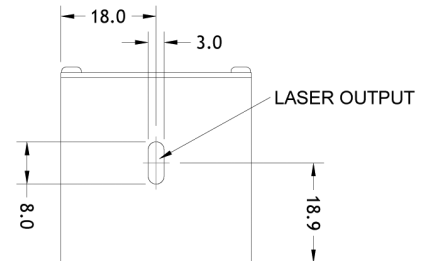
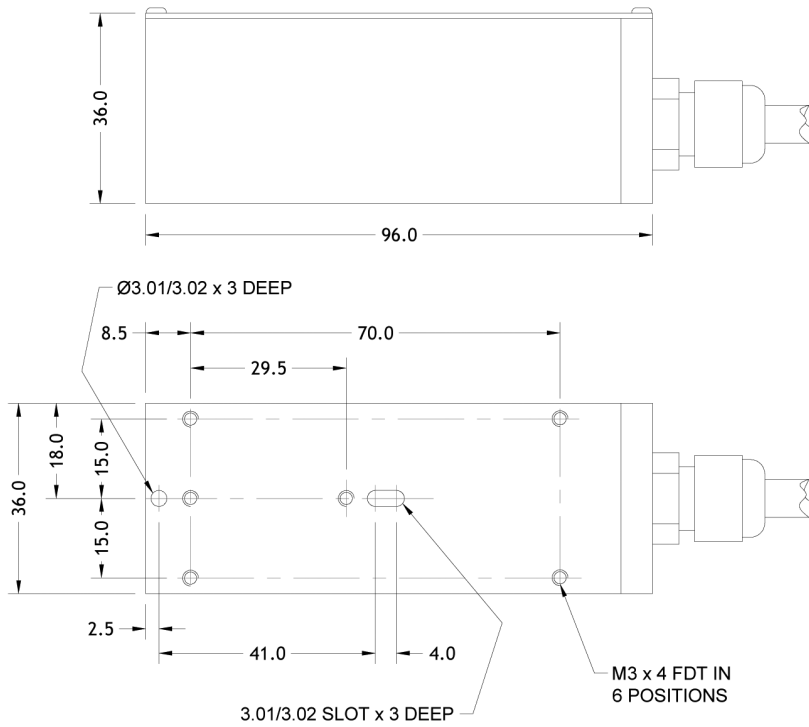

Electrical interface

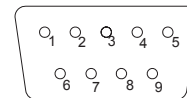

1. 5V ± 5% DC/3A (Temperature controller)
2. 12V ± 5% DC/0.5A (Laser driver)
3. Laser enable; 4-5V to enable, <1.2V to disable
4. Temperature OK signal, TTL logic level output (high = temperature locked)
5. External current control (0V fully on; 5V fully off)
6. 0V Temperature controller
7. 0V Laser driver
8. Diode operating current output; (Vop is scaled 10mV/mA laser diode current)
9. Monitor photodiode output (uncalibrated)

Laser controller

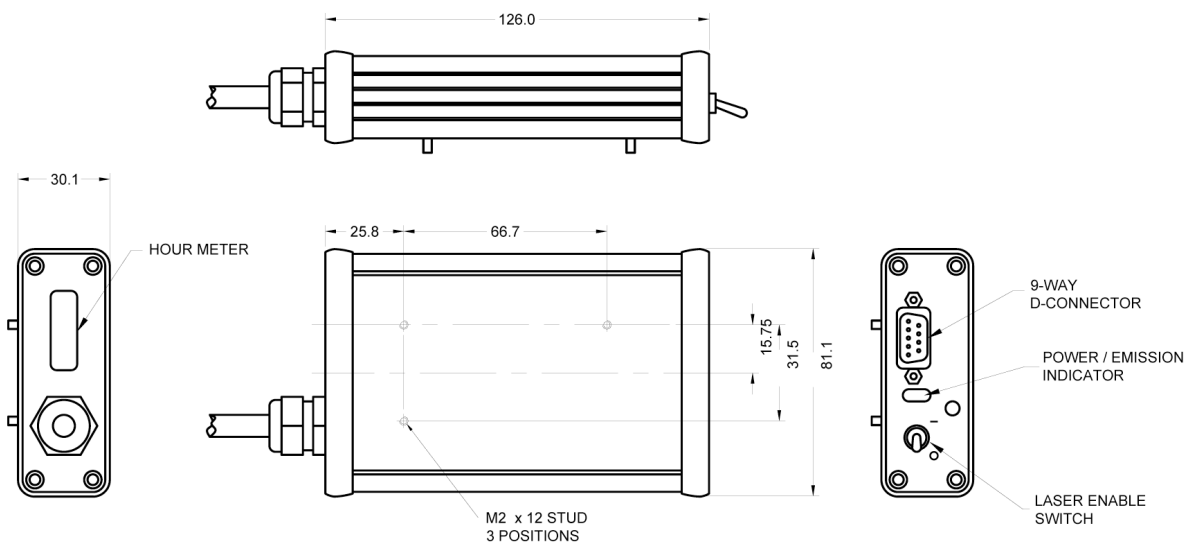

Fiber Optics



kineFLEX™

Robust laser beam delivery system for precision measurement applications

- Fiber coupling for DPSS, diode and gas lasers
- Highly repeatable and stable operation
- Greater than 65% coupling efficiency



kineFLEX-HPV™ / kineFLEX-UV™

Robust high power laser beam delivery system for precision measurement applications

- Input power up to 500mW for 488nm or higher
- Input power up to 20mW for 375nm
- OEM multiple wavelength versions available

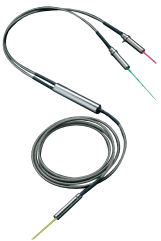

kineFLEX-DUO™

Robust laser beam delivery system for two laser sources at visible wavelengths

- Efficient and simple beam combination
- Visible wavelengths
- Rugged platform for industrial applications



laserPLATE™

Rapid and convenient mechanical mounting and packaging system for laser to fiber alignment

- Compatible and integrated laser to fiber coupling
- Combined laser chassis and heatsink
- Easy to integrate and align

For further information please contact:

Mitchell Point, Ensign Way, Hamble, Hampshire, SO31 4RF
Email: sales@qpl.qioptiq.com
Tel: +44 (0) 23 80 744 500 Fax: +44 (0) 23 80 744 501
www.qioptiq.com



www.qioptiq.com/diode-lasers
www.qioptiq.com/fiber-optics

iFLEX-Q3™ is a trademark of Qioptiq Photonics Ltd. Copyright ©2011 Qioptiq Photonics Ltd. Qioptiq Photonics Ltd. follows a policy of continuous improvement. Specifications are subject to change without notification.

Lasers



iFLEX2000™

Extremely reliable and robust fiber coupled laser designed for volume manufacturing

- UV, Visible and NIR Wavelengths
- Integrated drive and temperature control electronics
- Modular singlemode fiber delivery system

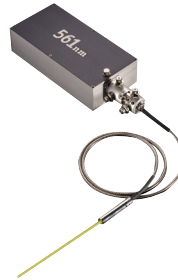

iFLEX-Mustang™

Fiber coupled solid state laser with on-board acousto-optic modulation

- DPSS lasers, 488, 532 and 561nm
- High long term stability and low noise
- 25mW of output power

Multi-laser Engines

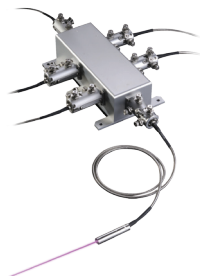

iFLEX-Adder™

5 into 1 fiber-coupled laser beam combination system

- True 'Plug & Play' capability enabling ultimate flexibility of laser suite
- Upgradeable from 2 to 5 wavelengths as required
- Compatible with kineFLEX™ and kineFLEX-HPV™



iFLEX-Viper™

The world's first integrated Multi-laser Engine

- Combines 5 wavelengths in one instrument
- Delivers wavelengths via a singlemode fiber optic cable
- On-board acousto-optic modulation up to 3MHz