

- Miniature Surface Mount
(17 x 12 mm)
- Enhanced Noise immunity
internal PLL
- **Very High sensitivity -112dBm**
- CMOS / TTL Output
- Stable Operating Frequency
- Sleep Mode $0.5\mu A$
- 3.3Vdc Operating Voltage
- Analog RSSI Output
- Low Power Consumption



Applications

- Security Systems
- Automation Systems
- Remote Gate Controls
- Remote Sensing
- Data Communications
- Sensor Reporting
- Pager Systems

Description

The Quasar UK AM-RX1 Super Heterodyne receiver module provides a complete Radio receiver which can be used to receive undecoded data from the range of Quasar (UK) transmitter modules.

The module is very simple to operate and offers low power consumption allowing for extended battery life without the need to power down the module.

Data can be fed directly into a microprocessor or decoding device, thus keeping the component count down and ensuring a low hardware cost.

All receivers are compatible, producing a CMOS/TTL output, and only require connections to power and antenna.

Pin Descriptions

Pin	Description
3.3V	Supply Voltage
GND	Ground
ANT	Connect External Antenna
RSSI	Received Signal Strength Output
DATA	Data Output
PD	Power Down Mode (Active High)

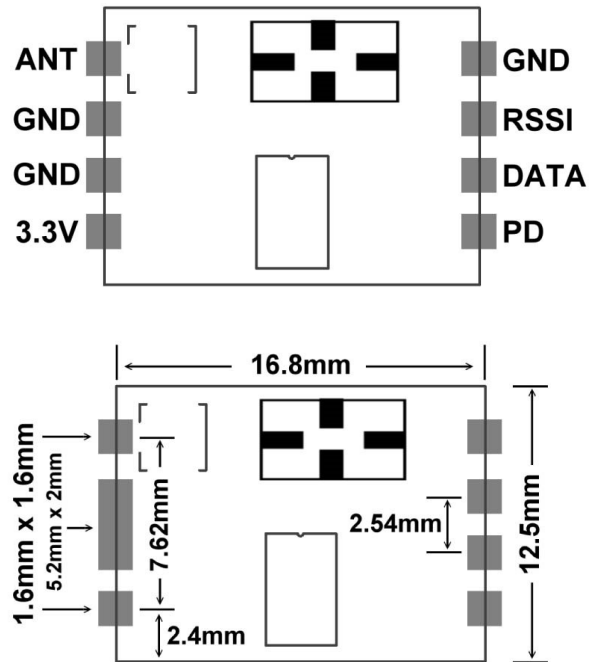

Electrical Characteristics

Ambient temp = 25°C unless otherwise stated.

Characteristic	Min	Typical	Max	Dimensions
Supply Voltage		3.3		Vdc
Supply Current		6		mA
Standby Current (PD=+Vcc)		0.5		µA
RF Sensitivity (Vcc=5V, 1Kbps AM 99% Square wave modulation)		-112		dBm @433MHz
Working Frequency		433.92		MHz
Turn On Time	25	30		mS
RSSI DC Output voltage		0.4—2		V
RSSI Response Slope @ -108dBm to -40dBm		25		mV/dBm
Operating Temperature Range	-40		+85	°C

Part Numbers

Part Number	Description	Range** (Metres)
QAM-RX1-315	AM Super Heterodyne Receiver Module, 315MHz	
QAM-RX1-433	AM Super Heterodyne Receiver Module, 433MHz	

**Range stated is optimum, direct line of sight. In worst conditions this can be reduced by over 50%

Typical Application

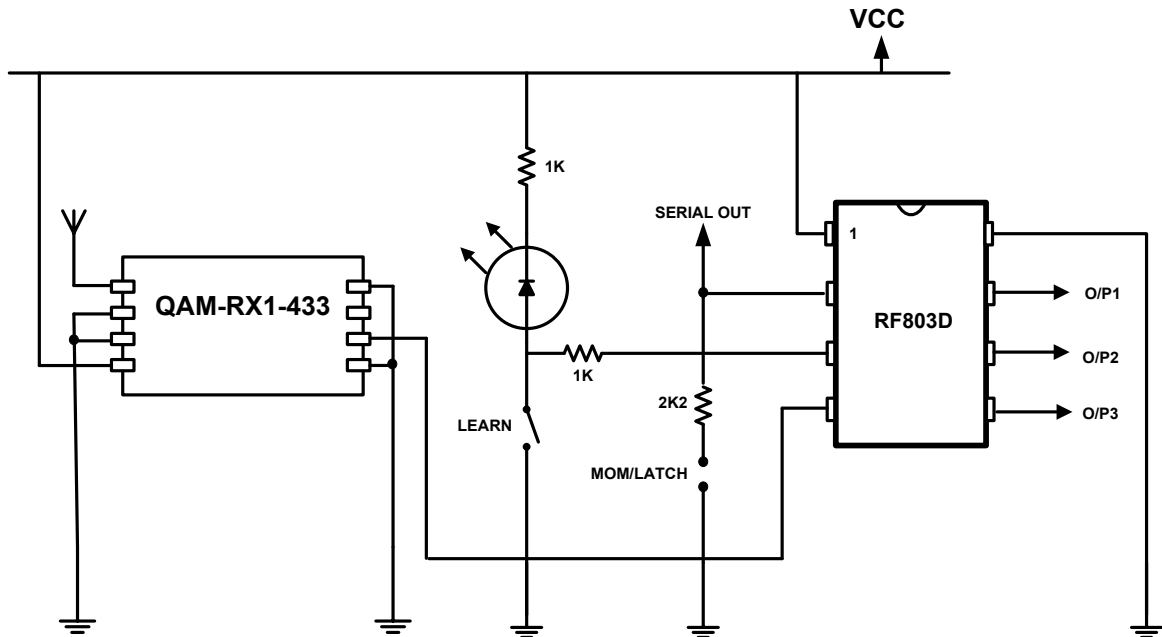

QuasarUK is an internet based company. All Sales / support and interface is via our website at

www.quasaruk.co.uk

for Sales:

Sales : sales@quasaruk.co.uk

for Support:

Support : sales@quasaruk.co.uk

Support Tel: 0907 639 0000

Calls charged at £0.60 per minute from a BT landline; other networks may vary.
 Callers must be 18 or over and have the bill payers permission. Service provided by
 StealthNET Ltd :08444150774

Disclaimer:

Whilst the information in this document is believed to be correct at the time of issue, QuasarUK Ltd does not accept any liability whatsoever for its accuracy, adequacy or completeness. No express or implied warranty or representation is given relating to the information contained in this document. QuasarUK Ltd reserves the right to make changes and improvements to the product(s) described herein without notice. Buyers and other users should determine for themselves the suitability of any such information or products for their own particular requirements or specification(s). QuasarUK Ltd shall not be liable for any loss or damage caused as a result of user's own determination of how to deploy or use R F Solutions Ltd's products. Use of QuasarUK Ltd products or components in life support and/or safety applications is not authorised except with express written approval. No licences are created, implicitly or otherwise, under any of QuasarUK Ltd's intellectual property rights. Liability for loss or damage resulting or caused by reliance on the information contained herein or from the use of the product (including liability resulting from negligence or where QuasarUK Ltd was aware of the possibility of such loss or damage arising) is excluded. This will not operate to limit or restrict QuasarUK Ltd's liability for death or personal injury resulting from its negligence.



AM SuperHeterodyne Receiver

Reader Response

It is our intention to provide you with the best documentation possible to ensure successful use of your QuasarUK product.

If you wish to provide your comments on organization, clarity, subject matter, and ways in which our documentation can better serve you, please email us your comments to the Technical Publications Manager

The following is a few suggestions to comments you may have.....

To: Technical Publications Manager

RE: Reader Response

From:

Company

Address

email:

Application:

Would you like a reply? Y / N

Datasheet: DSQAM-RX3-1

Questions:

1. What are the best features of this document?
2. How does this document meet your hardware and software development needs?
3. Do you find the organization of this document easy to follow? If not, why?
4. What additions to the document do you think would enhance the structure and subject?
5. What deletions from the document could be made without affecting the overall usefulness?
6. Is there any incorrect or misleading information (what and where)?
7. How would you improve this document?