



A Marmon Wire & Cable  
Berkshire Hathaway Company

# VITALink Taped Splice Straight Through Crimp

2 Hour Fire-Rated Splice  
VITALink MC Cables, **UL FHIT 120**

## Installation Instructions

### Description

The VITALink® Taped Splice Kit contains components and instructions for assembling a 2 hour fire-rated splice on VITALink® MC Cable.

Read instructions completely before starting.

For technical support, call RSCC Wire & Cable LLC at 800-327-7625.

### Tools Required

- Utility knife
- Pipe cutter
- Cable cutter
- Crimping tool (comply with UL listing)
- Channel Locks
- Needle Nose Pliers

### Materials Provided (RSCC part number VX99000-001)

- 2 Rolls of item A below: Self-sealing silicone rubber electrical tape
- 1 Roll of item B below: Fiberglass tape

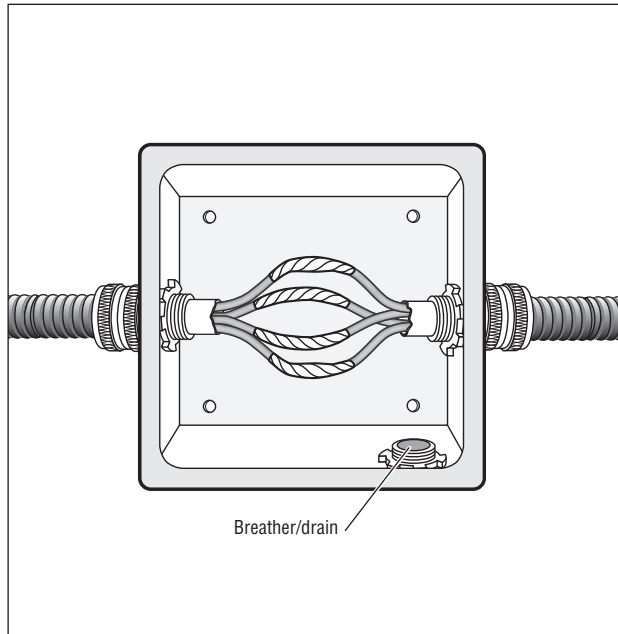
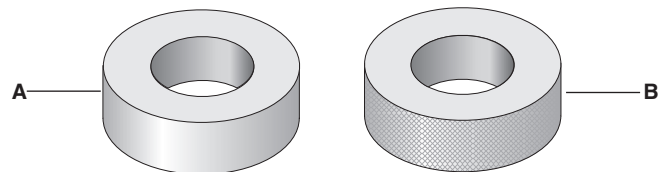

Picture does not represent all tape splice configurations.

### Additional Materials Required

- Adalet stainless steel NEMA 4X enclosure with silicone gasket (Series TRN4X-S)
- Stainless steel breather/drain
- American Connector stainless steel MC connector – Type WT-WSE (See Figure 1)
- Thomas&Betts tin plated copper compression two-way splice connector – standard barrel (See Figure 1)

### Materials not supplied

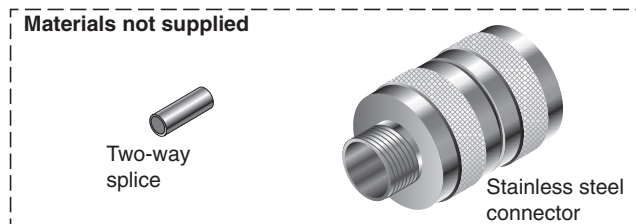

Figure 1

### WARNING:

The VITALink® MC Splice Kit system must be installed by qualified personnel familiar with generally accepted construction techniques and safe electrical practices.

- Take all appropriate precautions when installing splices, including following OSHA and other applicable regulations.

### IMPORTANT: Installation Guidelines

- To ensure this kit is installed correctly, read and follow all the safety warnings and instructions contained in this document.
- Only stainless steel enclosures and stainless steel MC connectors may be used.
- The installation must comply with all national and local electrical codes and all the requirements of the UL Electrical Circuit Integrity System listing (UL Category FHIT, System #120) requirements, and carefully follow the installation instructions.
- Ensure the cable is in good condition prior to commencing splice installation.
- Do not pull cables around corners that have sharp edges, such as corners in cable trays, or other obstructions.
- Support the cable in the manner and at the intervals described in the Electrical Circuit Integrity System listing.

## General

A stainless steel enclosure must be used. The enclosure shall be sized in accordance with the National Electric Code (NEC) but in no case smaller than Table 1 below. For reference, Table 2, in the last page of the installation guide, shows a more detailed list of available boxes that may be used to follow Table 1 rules. Cutouts should be positioned to allow splices to hang without touching the bottom of the box. Support the cable within 12 inches from box and every four feet on center thereafter. RSCC's Firewall® LSZH bonding wire shall be used inside the box (Not Shown). Do not introduce any materials into splice box that are not described within this installation guide.

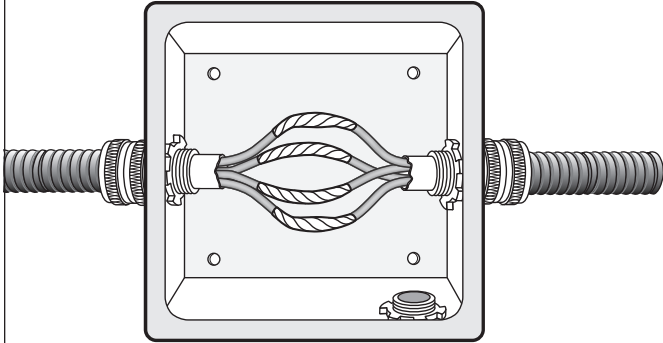

**Table 1 – Minimum Enclosure Size**

• The enclosure depth is 4 inches. minimum
• The minimum enclosure width shall be 8X the NPT of the MC connector.
• The minimum enclosure height shall be 6X the NPT of the MC connector.

## MC Connector Installation

**1**

The MC Connector must be American Connector WT-WSC series stainless steel

- Check to ensure you have all connector components

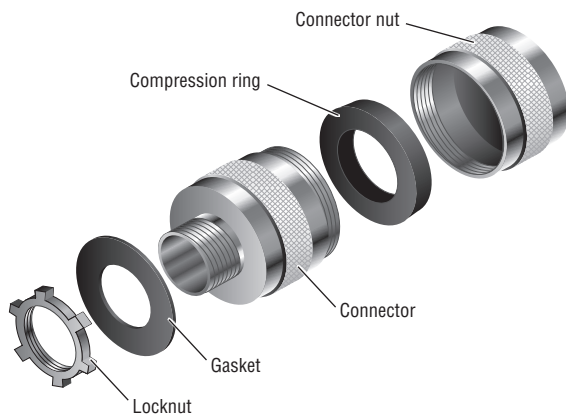

**2**

- Remove enough armor so the conductors can be easily spliced inside the enclosure. To avoid damaging the insulation on the conductors it is advisable to leave the white inner jacket until you insert the cable into the enclosure.
- Strip the black outer jacket to the length specified in the connector instructions.
- Inspect the edge of the armor for any burrs or sharp edges. Flatten or remove as necessary with needle nose pliers.
- Slide connector nut and compression ring over cable sheath/jacket

Note: for detailed instructions on preparation of cable, including removal of armor, see the VITALink® Installation Manual.

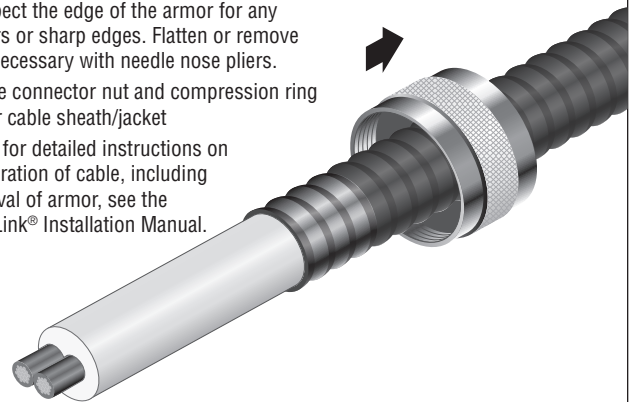

**3**

- Screw connector onto sheath and continue until tight.



**4**

- Tighten the connector nut onto the connector. Use channel locks as necessary.



**Straight Through Tape Splice Installation – Read Section completely before beginning installation****1 Secure Cable and Grounds**

- Prepare box cutouts and file sharp edges as needed. Clean up any metal shavings or oil. Some boxes come pre-cut.
- Install stainless steel breather drain on bottom of box.
- Ensure rubber gasket is on connector and insert cables into enclosure taking care not to nick or cut the cable core.
- Attach and secure the MC connector to the steel box using the locknut.
- Attach the earth tag and secure second locknut to the MC connector.
- Attach bare ground or Firewall LSZH green ground to the earth tag and ground stud to bond the connector and box to ground.

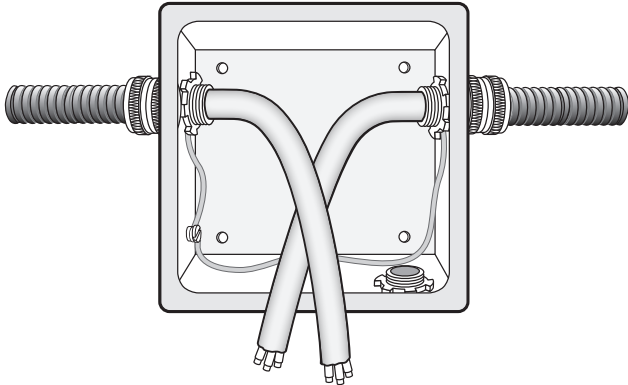
**2 Remove Inner Jacket**

- Taking care not to nick or cut the black insulation, carefully remove the white inner belting material leaving minimum of ½ inch where the cable exits the threaded part of the MC connector. One method to accomplish this is to cut through the end of the inner jacket ½ inch inward and use your hands to peel the jacket back. This is preferred over scoring the jacket lengthwise down the cable because it eliminates the risk of cutting the insulation accidentally. Damage to the insulation will require a new piece of cable.

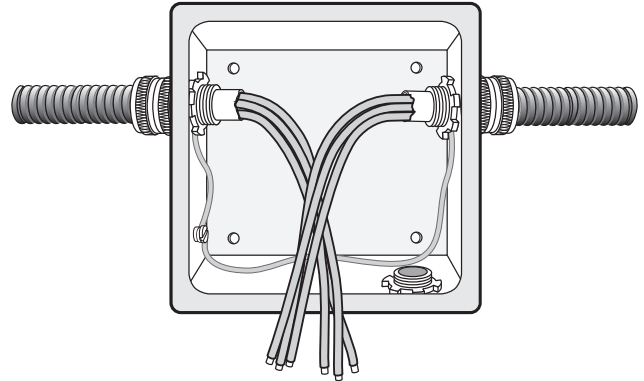
**3 Splice Layout and Crimp**

- Each crimp shall be cut so that they are staggered in the box when complete (see picture in step 7).
- It is recommended to train the conductors where the crimp will be located before cutting. This will help with the splice layout. Respect bend radius limits. See Step 7 for layout. Crimps should not line up vertically.
- Cut the ends of the cable square and carefully remove the black insulation to expose the amount of conductor specified by the manufacturer of the copper compression two-way splice connector barrel.
- Connect the conductors together using the appropriate copper compression two-way splice connector and crimping tool. Verify crimp is not loose.

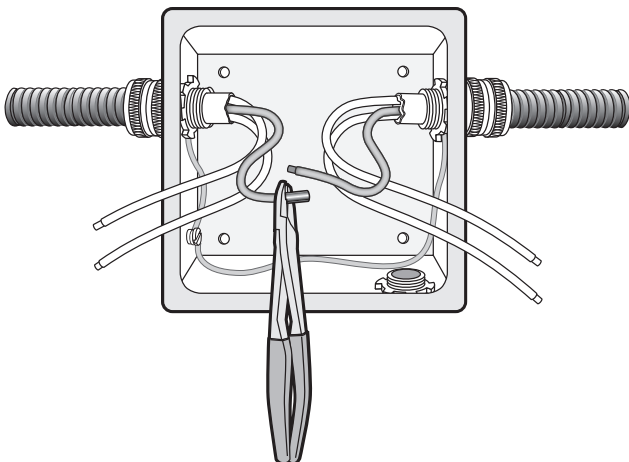
**4 Silicone Tape**

- The first tape to apply is the gray colored supplied self-fusing silicone rubber. Several silicone tape wraps shall be applied with tension, and one final layer shall be applied without tension. Instructions are provided below. Take care to keep tape clean. Dirty tape shall be discarded. It is critical that the silicone tape stays clean.
- Start the tape 1.5 inches back from the end of the insulation and tape over the conductor insulation. Pull tape with moderate tension (50% to 100% elongation) and begin to wrap helically towards crimp. Stretching the tape is required to cure the material.
- 50% Overlap is required. Each wrap of tape shall overlap onto itself half way. Continue over the bare conductor, the crimped connection, and extend 1.5 inches over the insulation on the opposite conductor. This is one pass. The next pass would follow the same process in reverse. There is not a need to cut the silicone tape after each pass.
- Continue this process. The number of required passes across the crimp, as described in the previous steps, to achieve the fire rating is shown in Table 2. One pass is defined as one pass across the crimp. For example starting 1.5 inches from the left side of the crimp and continuing 1.5 inches past the right side of the crimp at 50% overlap is one pass. Returning to the starting position would be the second pass, so on and so forth.

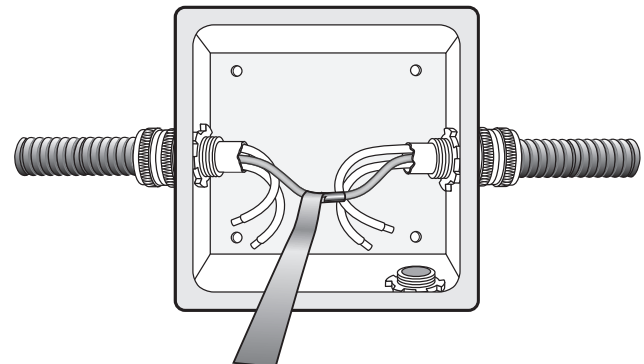

**Straight Through Tape Splice Installation Continued****5 Final Silicone Layer**

- After silicone tape has been wrapped according to Table 2, apply a final layer of the self-fusing silicone rubber tape with zero stretch or tension. Press down to avoid the tape ends from lifting before fusing takes place.

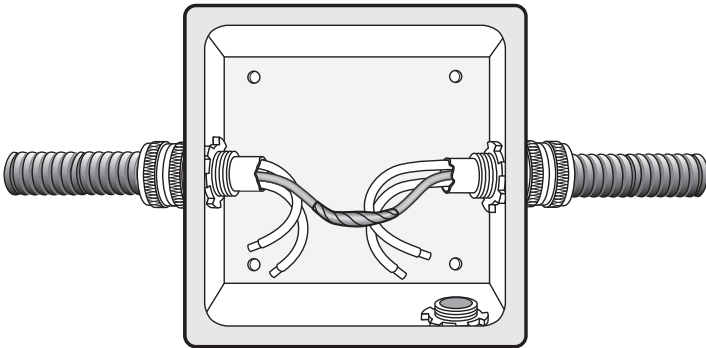
**6 Glass Protective Tape**

- The Second tape to apply is the white fiberglass tape.
- Start ½ inch past the end of the first layer of the silicone tape and apply one layer over the silicone tape. Each wrap of tape should cover over the previous wrap half way. Cover all surfaces of the silicone tape.
- Be careful not to cut silicone insulation or silicone tape when cutting the glass tape
- Additional layers are not required after silicone tape is covered.
- Use hand and apply pressure around crimp to ensure tape is adhering well.

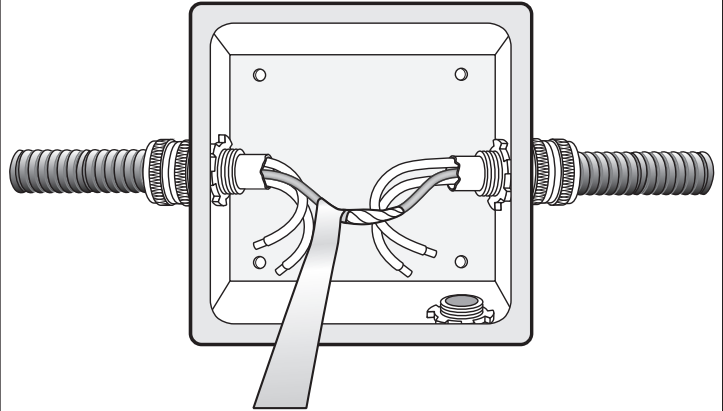
**7 Train Cables**

- It is important to train the cables neatly away from each other in the enclosure as shown. Avoid contacting the sides of the enclosure. Maintain at least a ½ inch spacing between the splices and the inside of the enclosure sides, top or bottom.

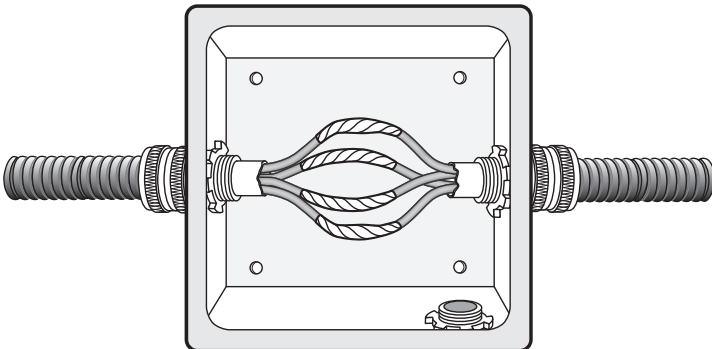
**8 Clean Up, Final Inspection, Close Box**

- Remove any loose debris from inside the box.
- Inspect box cover gasket for any damage and wipe clean if it is dirty.
- Secure the box cover and gasket to the box using the clips and tighten screws (not shown).

Table 2 – Tape Passes, Box Sizes, and Two-Way Connectors

Conductor Size	Conductor Number	Insulation Thickness (mils)	Number of Silicone Tape Passes Under Tension	Connector Hub OD (In)	Box Size WxHxD (In)	Thomas&Betts Two-Way Splice Connector Cat. No./Color
2 AWG	3	70	9	1.5	12x10x4	54507/ Brown
	4	70	9	1.5	12x10x4	
	5	70	9	2	16x14x4	
1 AWG	3	90	11	1.5	12x10x4	54508/ Green
	4	90	11	2	16x14x4	
	5	90	11	2	16x14x4	
1/0 AWG	1	140	16	1	8x6x4	54509/ Pink
	3	90	11	2	16x14x4	
	4	90	11	2	16x14x4	
	5	90	11	2.5	20x20x6	
2/0 AWG	1	140	16	1	8x6x4	54510/ Black
	3	90	11	2	16x14x4	
	4	90	11	2	16x14x4	
	5	90	11	2.5	20x20x6	
3/0 AWG	1	140	16	1	8x6x4	54511/ Orange
	3	90	11	2	16x14x4	
	4	90	11	2.5	20x20x6	
	5	90	11	2.5	20x20x6	
4/0 AWG	1	140	16	1	8x6x4	54512/ Purple
	3	90	11	2.5	20x20x6	
	4	90	11	2.5	20x20x6	
	5	90	11	2.5	20x20x6	
250 kcmil	1	155	18	1.25	10x8x4	54513/ Yellow
	3	105	13	2.5	20x20x6	
	4	105	13	2.5	20x20x6	
350 kcmil	1	155	18	1.25	10x8x4	54515/ Red
	3	105	13	2.5	20x20x6	
	4	105	13	3	24x18x6	
400 kcmil	1	155	18	1.5	12x10x4	54516/ Blue
	3	105	13	2.5	20x20x6	
	4	105	13	3	24x18x6	
500 kcmil	1	155	18	1.5	12x10x4	54518/ Brown
	3	105	13	2.5	20x20x6	
	4	105	13	3	24x18x6	
600 kcmil	1	170	19	2	16x14x4	54520/ Green
	3	120	14	3	24x18x6	
750 kcmil	1	170	19	2	16x14x4	54523-TB/ Black



**RSCC Wire & Cable LLC.**  
 20 Bradley Park Road  
 East Granby, CT 06026  
 USA  
 Tel: 860-653-8300  
 Fax: 860-653-8301  
[r-scc.com](http://r-scc.com)



**Marmon Engineered Wire & Cable LLC**

A Berkshire Hathaway Company