

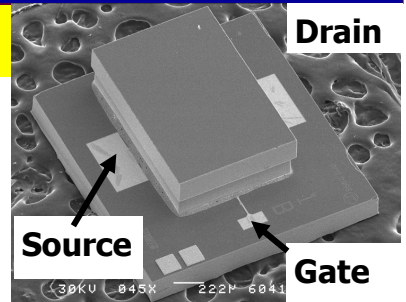

SPST, High-Isolation, RF-MEMS Switch DC to 20 GHz



RMSW201

Functional Block Diagram

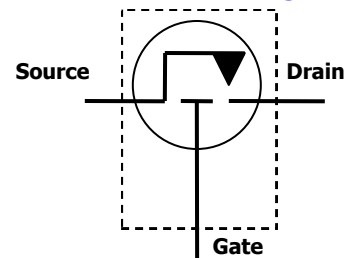

Features

- **High Isolation (20 dB typical @ 10 GHz)**
- **Low Insertion Loss (<0.5 dB typical @ 10 GHz)**
- **Near Zero Harmonic Distortion**
- **No Quiescent Power Dissipation**
- **Long Life (typical lifetime >100 billion cycles @ 27 dBm, >1 billion cycles @ 30 dBm)**
- **Hermetically sealed die designed for die-attach and wire-bond to board. Please contact us for other packaging options.**

Description

The RMSW201 is a Single Pole Single Throw (SPST) Reflective RF Switch utilizing Radant's breakthrough MEMS technology that delivers high linearity, high isolation, and low insertion loss in a chip-scale package configuration.

This device is ideally suited for use in many applications, such as RF and microwave multi-throw switching, radar beam steering antennas, phase shifters, RF test instrumentation, ATE, telecommunications, and broadband wireless access.

Typical Device Specifications

Insertion Loss DC 2 GHz 10 GHz 18 GHz	< 4 Ω < 0.30 dB < 0.45 dB < 0.60 dB	Lifecycle Cold-switched, 27 dBm Cold-switched, 30 dBm Cold-switched, 33 dBm Hot-switched, -20 dBm Hot-switched, -10 dBm Hot-switched, 20 dBm	> 10 ¹¹ cycles > 10 ⁹ cycles > 10 ³ cycles > 10 ¹¹ cycles > 10 ⁹ cycles > 10 ³ cycles
Isolation DC 2 GHz 10 GHz 18 GHz	> 1 G Ω > 35 dB > 21 dB > 18 dB	Control Gate-Source Voltage (on) Gate-Source Voltage (off) Control Power, steady-state Control Power, 1 KHz cycle rate	+/- 90 V 0 V < 1 nW < 2 μ W
Return Loss 2 GHz 10 GHz 18 GHz	< -27 dB < -22 dB < -20 dB	Switching speed On Off	< 10 μ s < 2 μ s
Input IP3 (Two-tone inputs 900 MHz and 901 MHz up to +5 dBm)	> 65 dBm	Operating temperature Maximum Minimum	85 $^{\circ}$ C -40 $^{\circ}$ C
		Storage temperature Maximum Minimum	150 $^{\circ}$ C -55 $^{\circ}$ C

Notes:

1. All RF measurements were made in a 50 Ω system.
2. Measurements include bond-wires from die to test-board.

- Phone: 978-562-3866
- Fax: 978-562-6277
- Email: sales@radantmems.com
Visit www.radantmems.com

Absolute Maximum Ratings

Maximum Temperature (10 seconds)	290 °C
(120 seconds)	250 °C
Maximum Voltage, Gate-Source	+/- 110 V
Maximum Voltage, Drain-Source	+/- 100 V

Recommended Application

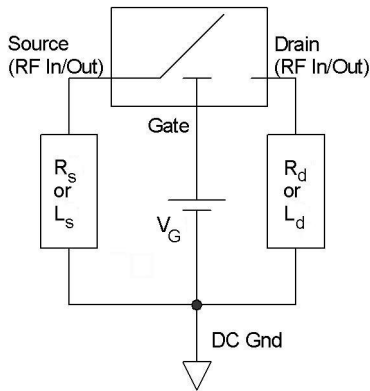

1. Resistors R_S and R_D (40 k Ω -100 k Ω) or inductors L_S and L_D should be used to provide a path to DC Ground from Source and Drain.
2. V_G may be of either polarity.
3. V_G rise-time should be at least 10 μ s for optimal lifetime.
4. Please refer to the application note entitled "Test and Handling of SPST RF-MEMS Switches" for more information. Contact us for driver solutions.

Nominal Device Dimensions

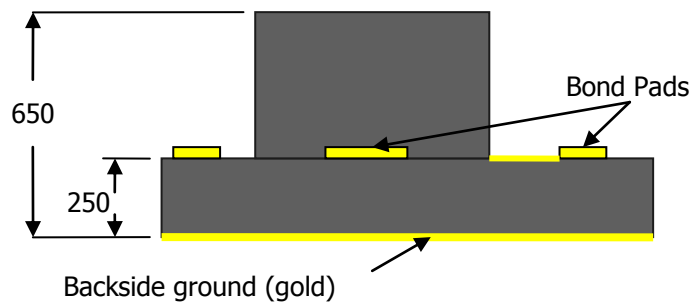
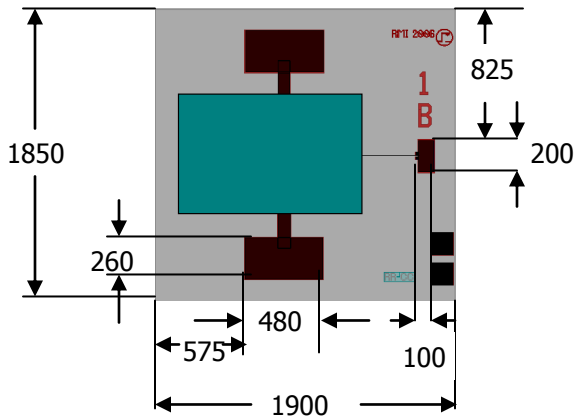

Dimensions are in micrometers.
Please contact us for a footprint in .gds or .dxf format.

Static sensitivity

This device has an ESD (HBM) sensitivity of 100 V. Use proper ESD precautions when handling. Please refer to the application note entitled "Test and Handling of SPST RF-MEMS Switches" for more information.

Die Assembly

The gold backside-metallization on the die is designed to be mounted with electrically conductive silver epoxy, or with a lower temperature solder which does not consume gold. Bond pads on the die are made of gold. Ball-bonds should be utilized to attach gold or aluminum 1 mil wires. Please refer to the application note entitled "Test and Handling of SPST RF-MEMS Switches" for more information.