

**CONSTRUCTION:**

- 1.1 Transformers to be made in accordance with MIL-PRF-27E TF5V03YY.
- 1.2 All material used in this construction must be greater than 180 C
- 1.3 Terminal to withstand Pull test of MIL-PRF-27

**ELECTRICAL:**

- 2.1 IR 500VDC, 10,000Mohms min.
- 2.2 DCR = (1-2) = 2.6 Ohms max (3-5)=.60 Ohms Max
- 2.3 I-EXCITE 118 VAC 50Hz (1-2)= .550A Max
- 2.4 VIN 50-400HZ 109-118VAC, VOUT = 34 - 48 VDC at 1 to 6ADC  
ALL CONDITIONS IN INPUT FROM AIRCRAFT

2.5 HIPOT = 600VAC

**ENVIRONMENTAL:**

- 3.1 Must survive Vibration MIL-STD-202 MD 204G and Shock MIL-STD-202 MD213C

**MECHANICAL:**

- 4.1 Mark Lead numbers on lead or part body
- 4.2 Mark: RAYCO ELECTRONICS 04620/5T54438 DATE CODE on body of part in accordance with MIL-STD-130. Number marking can be on side of unit

**APPROVED SOURCE OF SUPPLY**

- 5.1 Rayco Electronics Mfg Inc  
Cage Code (04620)  
1220 W. 130th St, Gardena CA 90247

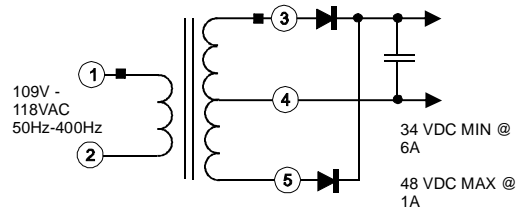

8-32 - .25 MIN 4PL

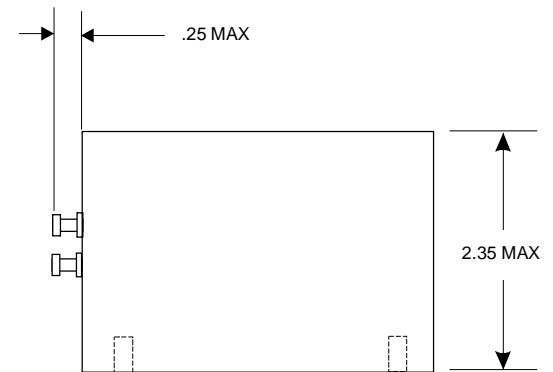
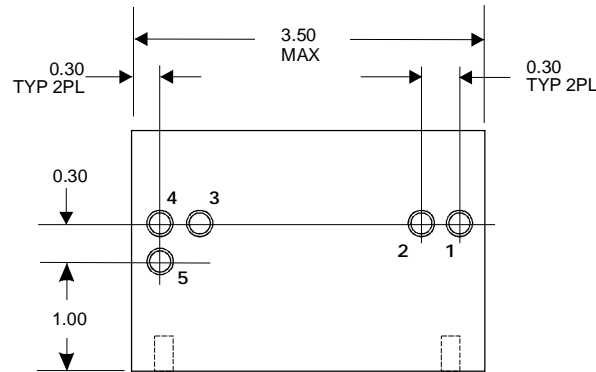
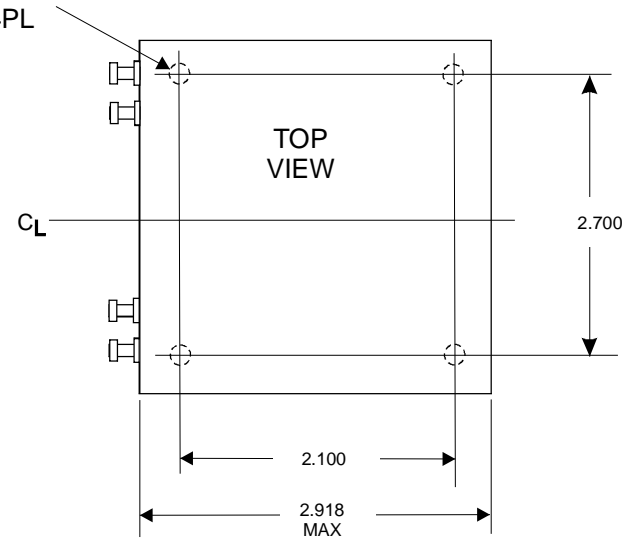

THIS DOCUMENT CONTAINS PROPRIETARY INFORMATION, AND SUCH INFORMATION MAY NOT BE DISCLOSED TO OTHERS FOR ANY PURPOSE NOR USED FOR MANUFACTURING PURPOSES WITHOUT WRITTEN PERMISSION FROM RAYCO ELECTRONICS MFG. INC..

	NEXT ASSY	DATE	<b>RAYCO ELECTRONICS</b>			
		7/1/02	GARDENA CA 90247			
	<b>TOLERANCES</b> UNLESS OTHERWISE SPECIFIED ARE IN INCHES AND AS BELOW	DWN	MMP			
		APP	MPP	CAGE	P/N	REV
DECIMAL			<b>04620</b>	<b>5T4438</b>		
.X	.XX	.XXX				
±0.1	±0.03	±0.010	SCALE	UNIT WEIGHT	SH 1 OF 1	
ANGLE = ± 5°						

