



RS9110-N-11-28: EVALUATION KIT

The Evaluation Kit for the RS9110-N-11-28 module offers users a flexible way of evaluating the features and performance of the module comprehensively. The kit consists of an evaluation board (EVB) with the module mounted, a serial cable, a USB power adapter, related software and documentation. The EVB can be connected to a Host system through the UART or SPI interfaces.

In the case of UART, the EVB can be connected to a PC using the serial cable or to the user's own EVB/PCB through custom connectors for the purposes of development and evaluation. From a PC, the user can configure the RS9110-N-11-28 EVB by using a Hyperterminal application using AT commands or the Wi-Fi Configuration Utility supplied as part of the software kit. In the case of SPI, the user should connect the Host board's SPI interface to the EVB's SPI header and configure the module through SPI based commands.

In addition to the Wi-Fi Configuration Utility which works in Windows OS, the software kit also includes reference driver software and applications which can be used to open and close sockets (TCP, UDP) and exchange data with a Peer PC over WLAN

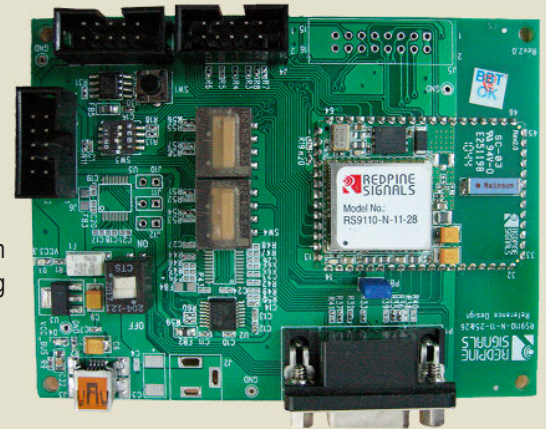

Features

- Option to connect to Host over UART or SPI
- Option to connect to PC or custom PCB over UART
- On-board RS232 driver IC to connect to a DB9 connector
- Software kit for UART includes Configuration Utility and Peer Applications
- Software kit for SPI includes Source Code for Reference Driver and Peer Applications
- Evaluation Kit includes a Power Supply adapter (5V)

Purpose

- Development of System including customer PCB and RS9110-N-11-28 module
- Evaluation of RS9110-N-11-28 module's features
- Interoperability verification

Specifications

Network Standard Support	IEEE802.11a/b/g/n
Data Rates	802.11n:6.5,13,19.5,26,39,52,58.5,65Mbps 802.11g:6,9,12,18,24,36,48,54Mbps 802.11b:1,2,5.5,11Mbps
Frequency Band	2.412-2.484 GHz 4.900-5.850 GHz
Modulation Techniques	OFDM with BPSK,QPSK,16-QAM, and 64-QAM802.11b with CCK and DSSS
Wireless Security	802.11i: WPA/WPA2-PSK, WEP
Host Interfaces	SPI, UART
NetworkProtocols	TCP, UDP, IPv4, ARP, ICMP, DHCP Client
Serial data rate	Supports all standard baud rates from 9600 to 3.6 Mbps.
Configuration	AT commands over UART, SPI commands over SPI interface
Antenna	EVB comes with an embedded chip antenna
Supply Voltage to EVB	5V

Software Package

The Software Package for UART includes the following items:

- Configuration Utility GUI (Windows OS)
- WLAN Firmware in Binary form
- Peer Applications

The Software Package for SPI includes the following items:

- Reference Driver for SPI interface
- Firmware in Hexadecimal form
- Peer Applications

Documentation

- Datasheet for RS9110-N-11-28 module
- Evaluation Board User Guide – for SPI and UART
- Software Programming Reference Manual for software development
- Module Integration Guide for hardware integration

RS9110-N-11-28 DIAGRAM

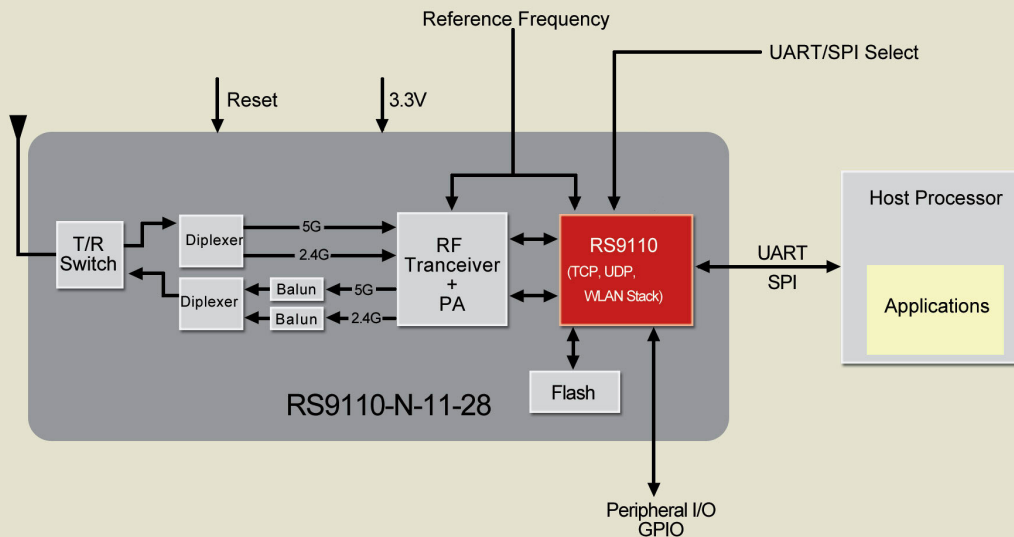

For additional information, please contact Sales at Redpine Signals, Inc.:

Redpine Signals, Inc. • 2107 North First Street • Suite 680 • San Jose, CA 95131
Phone: +1 408 748 3385 • Email: sales@redpinesignals.com

www.redpinesignals.com

Redpine Signals, Inc. reserves the right to make changes to the product(s) or information contained herein without notice. No Liability is assumed as a result of their use or application. Redpine, Redpine Signals, the Redpine logo, Expanding Wireless Horizons and Lite-Fi are trademarks of Redpine Signals, Inc. All other company names, products and logos are registered trademarks of their respective companies.

© Copyright 2008 Redpine Signals, Inc. All Rights Reserved

Connect-io-nTM
Wi-Fi® I/O for Microcontrollers