

Installation

Refer to Figure 2 as a typical installation of a Fieldbus Connection System Labkit (Labkit). The Power Hub included with the Labkit has two terminators and a power conditioner built-in. No other accessories are required to setup a fieldbus segment. Four additional spur connections may be added by attaching an FCS-E Expander Block.

Mounting

The Power Hub included with each Labkit is designed to mount on 35 mm DIN rail using the mounting tabs on the back of each unit. Use of DIN rail end stops is recommended for DIN rail installation. In addition, mounting holes on either side of the Power Hub base allow screw mounting. Mounting can be vertical or horizontal. If used outside a lab environment, Power Hubs should be installed inside an enclosure with a minimum rating of IP 54.

Wiring Instructions

Connect the wall transformer circular connector plug to the jack on the Power Hub and plug the wall transformer into a power outlet. The Labkit comes with cables installed on all four spur ports. The cables on the power connector side of the Power Hub may be connected to National Instruments Foundation Fieldbus Host or Monitor cards installed in a PC. The remaining two cables are ready to connect to fieldbus devices. The red wire is connected the + terminal of the device, the black wire is connected to the - terminal of the device. A cable shield terminal marked by an S is available for connection when using twisted, shielded pair wire. Fieldbus devices may be connected to any of the four spur ports on the Power Hub. The maximum cable length between any two devices on the network is 100 meters.

Testing/Troubleshooting

Once AC power has been connected to the Power Hub, the green power LED on the Power Hub should be lit, indicating that power is available to each of the four spur ports. **If the green LED is not lit**, verify the integrity and polarity of the cable connections to the Power Hub, that the voltage measured at the spur ports is greater than 9VDC, that no shorts exist in the cables, and that the power supply is connected to the Power Hub and an operating power outlet.

If using SpurGuard™ current limiters, verify that none of the red short circuit LED's are lit. **If any of the red short circuit LED's are lit**, remove the three-conductor plug from the affected spur connection. Locate and repair the short circuit on the spur cable before reconnecting.

Operation

During normal operation, the green power LED should be lit. If the green LED is not lit, follow the instructions in the Testing/Troubleshooting section above.

Maintenance Requirements

Power Hubs contain no user serviceable parts. Non-functioning units should be returned to the manufacturer for replacement or repair.

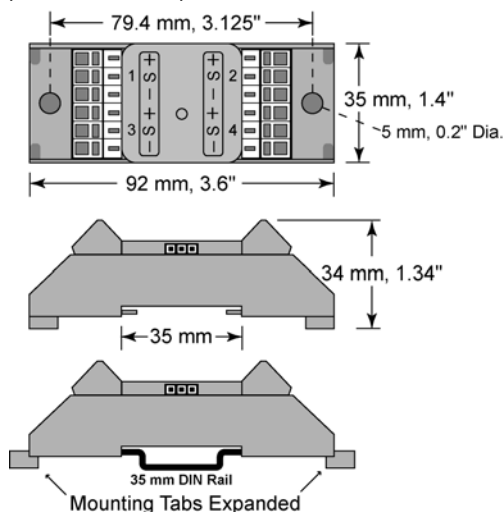

Figure 1

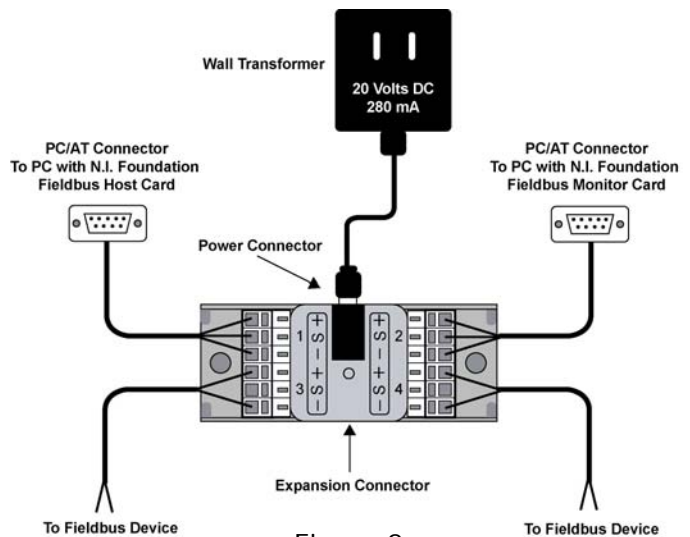

Figure 2



FCS-LABKIT Fieldbus Labkit Series EMC Summary

European Union EMC Tests in accordance with EN61326 EMC Product Family Standard for measurement, control and laboratory equipment.

Test Items: **FCS-PH**

Other products conforming based on these test results include:

FCS-LABKIT-110-ST	FCS-LABKIT-220-ST
FCS-LABKIT-110-CL	FCS-LABKIT-220-CL
FCS-LABKIT-110-PL	FCS-LABKIT-220-PL

**European Union Electromagnetic Compatibility (EMC) Tests
in accordance with EC Council Directive 89/336/EEC**

Emissions Tests per EN61326

Result	Standard	Description	Port	Comments
Pass	EN61326	Radiated Emissions	Enclosure	Class B
N/A	EN61326	Conducted Emissions	AC Mains	Test Not Required

Immunity Tests per EN61326 Annex A

Result	Standard	Description	Port
Pass	EN61000-4-2	Electrostatic Discharge Immunity	Enclosure
Pass	EN61000-4-3	RF Electromagnetic Field Immunity	Enclosure
Pass	EN61000-4-4	Electrical Fast Transient/Burst Immunity	DC Port
Pass	EN61000-4-5	Surge Immunity	NA
Pass	EN61000-4-6	RF Conducted Immunity	DC Port
N/A	EN61000-4-8	Magnetic Field Immunity	N/A
N/A	EN61000-4-11	Voltage Dips/Short Interruptions Immunity	N/A

I, Mike Strauser, representative for Relcom Inc., verify that the product tested is representative of production products to be sold.

