

# Advanced Transportation Controller Cabinet (ATCC) Component Overview



081716© EDI

# ATCC Architecture

- The ATC Cabinet architecture is based on the ITS Cabinet v1 national standard and is often referred to as Version 2.
  - 19" Rack mounted form factor with a Serial Bus architecture
- The major design goals of the ATCC include the following:
  - Double density assemblies and components.
    - Vertical rack space is a premium
    - Modular Assembly design facilitates configuration and maintenance
  - Fail-safer cabinet design techniques to increase safety
  - Personnel safety; touch safe, NFPA 70 Requirements
  - Increased monitoring functionality to boost safe intersection operation
    - CMU load current monitoring – Detect a dark approach immediately
    - Flasher monitoring
    - Advanced diagnostics using the patented Diagnostic Wizard
  - Maximize cabinet power efficiency and provide LED signal compatibility for ultra-low power signal heads
  - Available in 120 Vac and 48Vdc Low Voltage versions

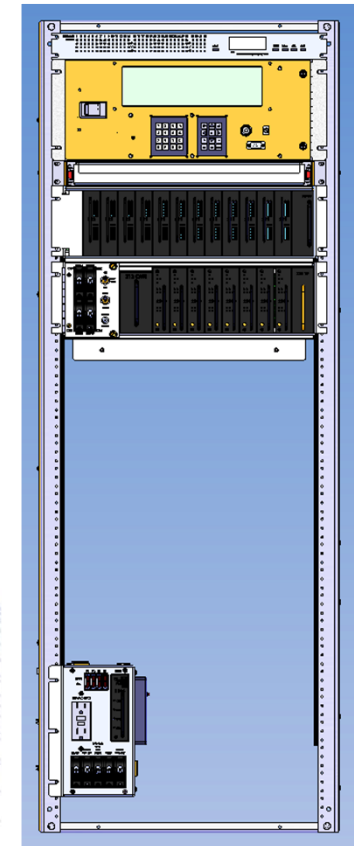

# Output Assembly and Serial Bus

- The ATCC architecture is very modular and interconnected via three internal serial busses.
  - Serial Bus #1 (blue) connects the Controller Unit (CU) to the CMU.
  - Serial Bus #2 is available for any user application (not shown)
  - Serial Bus #3 (red) connects the CMU to each of the HDSP units, the HDFU, and the ADU.

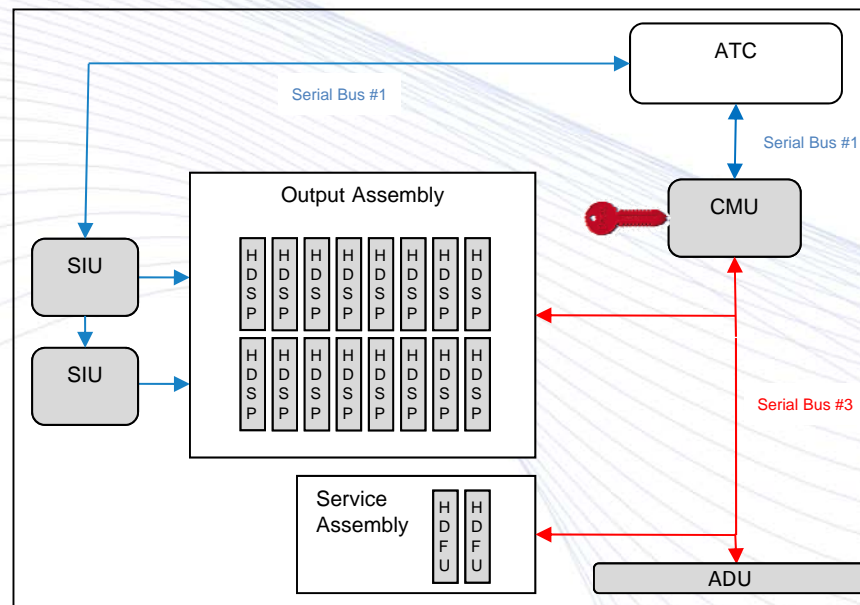

# ATCC Cabinet Components

- Model 2202 Universal Switch Pack / Flasher (HDSP-FU)
- Model 2212 Cabinet Monitor Unit (CMU2)
  - *ECcom* Signal Monitor Software
  - *MonitorKey* Software
- Model 2220 Auxiliary Display Unit (ADU)
- Model 2218 Serial Interface Unit (SIU2)
  - *FrontPanel* Diagnostic software
- Model 2216 Cabinet Power Supply (PS)
- Model 2217 Cabinet Power Supply (PS)
- Model 2205 High-Density Flash Transfer Relay Unit (HDFTR)



# Model 2202 Universal HDSP-FU

- Interchangeable between load switch and flasher function
  - HDSP: High Density Switch Pack
  - HDFU: High Density Flasher Unit
- 1.2" x 4.5" card format with DIN style connector
- HDSP: Two channels per card
  - Six outputs rated at 5 mA to 1 Amp (1-120 watts)
  - Over-current protected
  - Load current monitored on each RYG output
- Reports both Voltage and Current data to the CMU via SB#3.
- LED compatible to <2 watts, no leakage
- CMU controlled output over-ride for fail-safer operation
- "ID" indicators driven by CMU based diagnostics for simplified trouble-shooting



# Model 2202 Universal HDSP-FU

- 1.2" x 4.5" card format with DIN style connector
- HDFU: Two channels per card
  - Four outputs rated at 5mA to 1.8 Amps each
  - Over-current protected
- Interchangeable with the HDSP function
- Reports Voltage and Current data to the CMU on SB#3.
- Provides Flasher Alarm diagnostics to the CMU and CU
- The HDFU is located in the Service Assembly (SA)
  - All assemblies except the SA and Field Termination Panel can be replaced while the intersection is in flash mode.

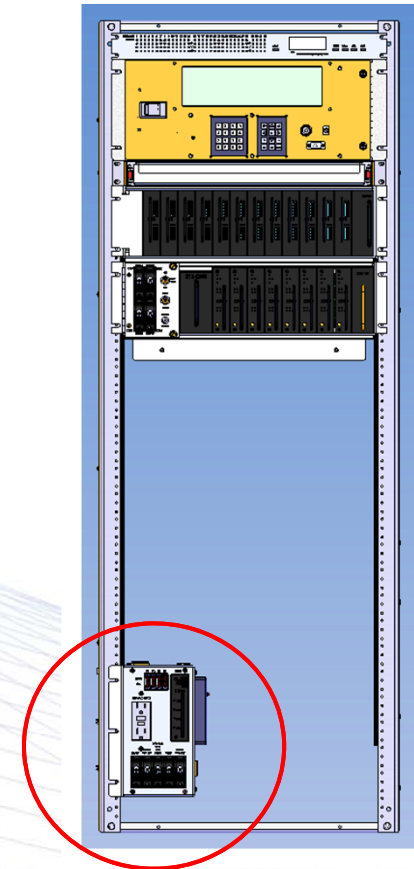

# Model 2202 Installation & Operation

- Each HDSP-FU *iPack*<sup>®</sup> reads a serial bus address that is built into the rack slot. No user programming is necessary.
- The Rx/Tx indicators display SB#3 activity with the CMU.
- The CH indicators (RYG) reflect the HDSP inputs as driven by the SIU.
- The FLASHER 1 & 2 indicators reflect the flasher output voltages.
- The blue ID indicators for each channel are driven by the CMU
  - Typically they identify channels involved in the current fault.
  - They are also used to identify the selected channel(s) when the CMU is displaying status on the ADU.
- The DIAG indicator will illuminate when an internal self test has failed.
- Note: When the CMU is in the Fault mode, all HDSP outputs will be over-ridden to the Off state by the CMU.





# Model 2212 Cabinet Monitor Unit

- The CMUip-2212 is a modular signal monitor capable of monitoring 32 channels.
- Voltage and current data is received from each HDSP and HDFU device via SB #3.
- All configuration programming is provided in the Datakey, a non-volatile memory device.
  - The EDI *MonitorKey*® software is used to program the Datakey
- The ADU2220 provides the cabinet display capability for the CMU and access to the EDI *SmartMonitor*® technology.





# Model 2212 Cabinet Monitor Unit

- Each output of the HDSP reports signal load current to the CMU.
  - *Safety*: Open-load malfunctions are detected right away
- Load Current monitoring simplifies trouble shooting
  - The CMU reports without ambiguity whether the signal head was On, Off, or No-load.
  - Voltage and Current relates directly to power delivered to the signal head.
- Built-in *Diagnostic Wizard*: The CMUip-2212 analyzes the ATC output commands and HDSP field input status.
  - Isolates whether the cabinet fault was caused by an ATC malfunction or a failure in the load bay or field wiring,
  - Identifies the faulty channel(s) and outputs directly,
  - Provides guidance on how the technician should isolate the cause of the malfunction.

*Just press the HELP button!*



# Model 2212 Cabinet Monitor Unit

- The EDI *ECcom* software is used to retrieve and display event data from the CMU. ([www.EDIttraffic.com/products-page/eccom-software](http://www.EDIttraffic.com/products-page/eccom-software))
- Event Logging
  - Nonvolatile event log records Previous Fault events, AC Line events, Configuration changes, Monitor Resets, cabinet temperature and true RMS voltages and currents for all field inputs.
  - A real time clock stamps each event with time and date.
- Signal Sequence History Log
  - The Signal Sequence History Log graphically displays up to 30 seconds of signal status to help diagnose intermittent and timing related faults.

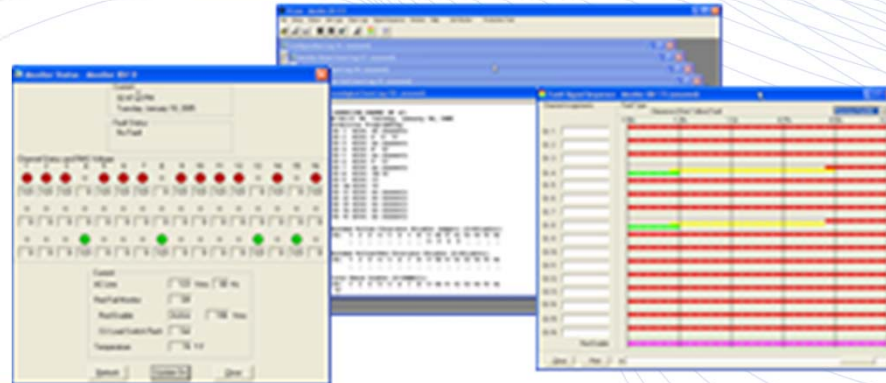

# MonitorKey<sup>®</sup> Programming Tool

- The *MonitorKey* software and USB *MonitorKey* programming tool are used to compile the CMU configuration parameters into data for the nonvolatile Datakey. ([www.editraffic.com/products-page/monitorkey-programming-tool](http://www.editraffic.com/products-page/monitorkey-programming-tool))
- Configuration files can be saved or loaded from disk. These can be templates or actual deployed data sets.
- The Datakey can be read, written, or copied.
- A text report of the configuration parameters can be printed.
- For each CMU monitoring function, a form (window) is provided to fill in the parameters. A Setup Wizard is provided to automatically fill in many of the forms.

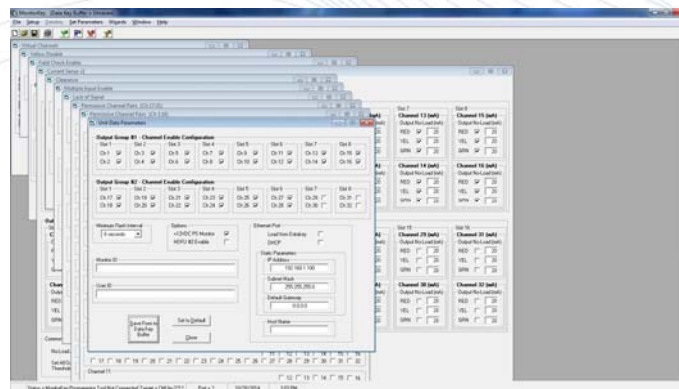

# MonitorKey<sup>®</sup> Setup Wizard

- A *Parameter Setup Wizard* is provided to automatically fill in many of the channel related parameter forms.
  1. Set these parameter forms manually:
    - Unit Data
    - Permissive Channel Pairs
    - Dark Channel Maps 2 & 3
    - Current Sense Thresholds (if necessary)
    - Virtual Channels (if necessary)
    - Flashing Yellow Arrow (if necessary)
  2. The *Parameter Setup Wizard* will then complete these forms:
    - Lack of Signal Enable
    - Multiple Input Enable
    - Clearance Enable
    - Current Sense Enable
    - Field Check Enable
    - Yellow Disable
- Set the parameter forms in list #1 above, then run the Parameter Setup Wizard. The result will be a configuration database ready to deploy.





# Current Sense Parameters

- Enable each R, Y, & G output for current monitoring if a signal load is connected to that HDSP output.
- The No-Load Threshold value is set low to detect the safety case of a dark approach. (Default = 20 mA)
- *Maintenance monitoring of load current to detect a partial outage is not recommended without full characterization of the signal heads over time, temperature, ambient light, voltage and brand.*

Current Sense v2

A check mark ENABLES an Output for No-Load Current Monitoring  
Load Current values are rounded to the nearest Scaled MilliAmp value

Output Group #1	Slot 2	Slot 3	Slot 4	Slot 5	Slot 6	Slot 7	Slot 8
<b>Channel 1 (mA)</b> Output No-Load (mA)	<b>Channel 3 (mA)</b> Output No-Load (mA)	<b>Channel 5 (mA)</b> Output No-Load (mA)	<b>Channel 7 (mA)</b> Output No-Load (mA)	<b>Channel 9 (mA)</b> Output No-Load (mA)	<b>Channel 11 (mA)</b> Output No-Load (mA)	<b>Channel 13 (mA)</b> Output No-Load (mA)	<b>Channel 15 (mA)</b> Output No-Load (mA)
RED <input checked="" type="checkbox"/> 20	RED <input checked="" type="checkbox"/> 20	RED <input checked="" type="checkbox"/> 20	RED <input checked="" type="checkbox"/> 20	RED <input checked="" type="checkbox"/> 20	RED <input checked="" type="checkbox"/> 20	RED <input checked="" type="checkbox"/> 20	RED <input checked="" type="checkbox"/> 20
YEL <input checked="" type="checkbox"/> 20	YEL <input checked="" type="checkbox"/> 20	YEL <input checked="" type="checkbox"/> 20	YEL <input checked="" type="checkbox"/> 20	YEL <input checked="" type="checkbox"/> 20	YEL <input checked="" type="checkbox"/> 20	YEL <input checked="" type="checkbox"/> 20	YEL <input checked="" type="checkbox"/> 20
GRN <input checked="" type="checkbox"/> 20	GRN <input checked="" type="checkbox"/> 20	GRN <input checked="" type="checkbox"/> 20	GRN <input checked="" type="checkbox"/> 20	GRN <input checked="" type="checkbox"/> 20	GRN <input checked="" type="checkbox"/> 20	GRN <input checked="" type="checkbox"/> 20	GRN <input checked="" type="checkbox"/> 20
<b>Channel 2 (mA)</b> Output No-Load (mA)	<b>Channel 4 (mA)</b> Output No-Load (mA)	<b>Channel 6 (mA)</b> Output No-Load (mA)	<b>Channel 8 (mA)</b> Output No-Load (mA)	<b>Channel 10 (mA)</b> Output No-Load (mA)	<b>Channel 12 (mA)</b> Output No-Load (mA)	<b>Channel 14 (mA)</b> Output No-Load (mA)	<b>Channel 16 (mA)</b> Output No-Load (mA)
RED <input checked="" type="checkbox"/> 20	RED <input checked="" type="checkbox"/> 20	RED <input checked="" type="checkbox"/> 20	RED <input checked="" type="checkbox"/> 20	RED <input checked="" type="checkbox"/> 20	RED <input checked="" type="checkbox"/> 20	RED <input checked="" type="checkbox"/> 20	RED <input checked="" type="checkbox"/> 20
YEL <input checked="" type="checkbox"/> 20	YEL <input checked="" type="checkbox"/> 20	YEL <input checked="" type="checkbox"/> 20	YEL <input checked="" type="checkbox"/> 20	YEL <input checked="" type="checkbox"/> 20	YEL <input checked="" type="checkbox"/> 20	YEL <input checked="" type="checkbox"/> 20	YEL <input checked="" type="checkbox"/> 20
GRN <input checked="" type="checkbox"/> 20	GRN <input checked="" type="checkbox"/> 20	GRN <input checked="" type="checkbox"/> 20	GRN <input checked="" type="checkbox"/> 20	GRN <input checked="" type="checkbox"/> 20	GRN <input checked="" type="checkbox"/> 20	GRN <input checked="" type="checkbox"/> 20	GRN <input checked="" type="checkbox"/> 20

# Flashing Yellow Arrow Parameters

- Six FYA Channel Pairs are supported
- The OLP channel of the pair is the R-Y-fY channel
- The Protected Channel of the pair is the Green arrow channel

Load Switch #A  
Protected Channel



Load Switch #B  
Permissive Channel  
(OLP)

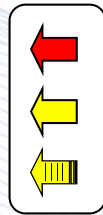

- The OTP channel is the Opposing Thru Phase, and is needed only if Yellow Trap monitoring is enabled.
- Options:
  - Flash Rate Detect
  - Red & Yellow Input Enable
  - Yellow Trap Detect

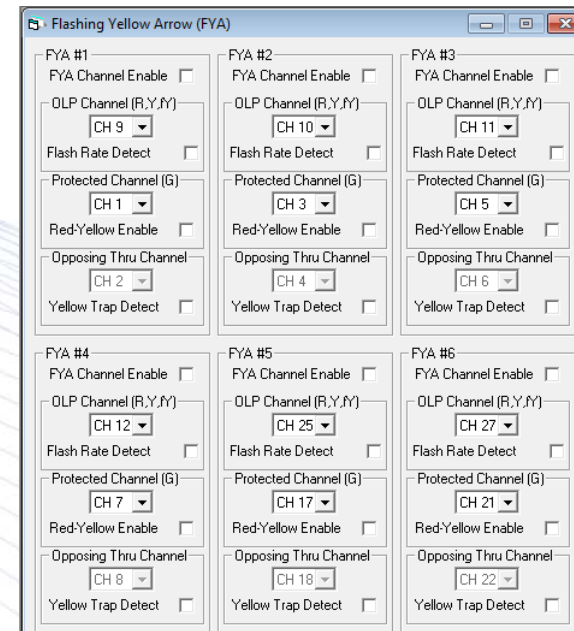

# MonitorKey<sup>®</sup> Programming Procedure

- Open a saved template file (\*.key) and manually configure the necessary forms for the cabinet.

Or...

- Run the Parameter Setup Wizard, and configure the remainder of the forms manually.
- Resolve any Parameter Check errors and warnings displayed.
- Write the resulting configuration data to a Datakey device.



# Model 2220 Auxiliary Display Unit

- RYG status plus a Blue LED for fault status provides a full view of the intersection signal states.
- The LCD menu driven display provides detailed status information from the CMUip-2212 along with an interface to the patented EDI *SmartMonitor*<sup>®</sup> technology.
  - The built-in *Diagnostic Wizard* provides a concise view of the signal states involved in the fault, pinpoints faulty signal inputs, and provides guidance on how the technician should isolate the cause of the malfunction.
- View status, configuration settings, voltages, and event logs.

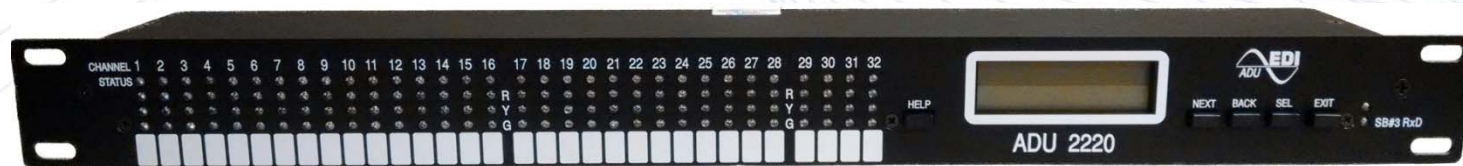



# Model 2220 Auxiliary Display Unit

- Status Menu
  - Fault Status
  - Field Voltages
  - Field Currents
  - Cabinet Control signals
  - Flasher Alarms
- Clear Logs
- View Firmware Level
- Set / View Config Menu
  - View Logs
  - View CMU Configuration
    - Unit Data
    - Permissives
    - Lack of Signal Enable
    - LOS Dark Maps
    - Multiple Enable
    - Clearance Enable
    - Field Check Enable
    - Yellow Disable
    - Current Sense
    - Virtual Channels
    - Flashing Yellow Arrow

# SmartMonitor<sup>®</sup> Diagnostic Wizard

- The **HELP** button launches the *Diagnostic Wizard* at the STATUS level or when displaying any Previous Fail (PF) event log.
- The first page displays a general definition of the current fault.
  - “With FC Status” indicates that the fault was caused by a load bay or field issue
  - Otherwise, the CU may have caused the fault. Consider also improper configurations.
- The next page identifies the channels and outputs that were detected in fault. “Faulty” channels are identified by the Blue status LEDs.
- Other pages may be inserted depending on the conditions:
  - Field Check Status (FC Status)
  - Recurrent Pulse Status (RP Status)
- The final page suggests some common causes for the fault, and tips for further trouble shooting.



# SIU-2218 Serial Interface Unit

- One SIU is located in each Input and Output Assembly.
  - 54 programmable input / outputs
  - 4 opto-isolated inputs
- The SIU converts serial data *from* the ATC into parallel outputs to the HDSPs.
- The SIU converts parallel inputs from the detectors into serial data *to* the ATC.



# SIU *FrontPanel* Software

- EDI SIU *FrontPanel* diagnostic software utilizes the SIU serial port for Input or Output Assembly diagnostics.  
([www.EDIttraffic.com/products-page/siu-frontpanel](http://www.EDIttraffic.com/products-page/siu-frontpanel))

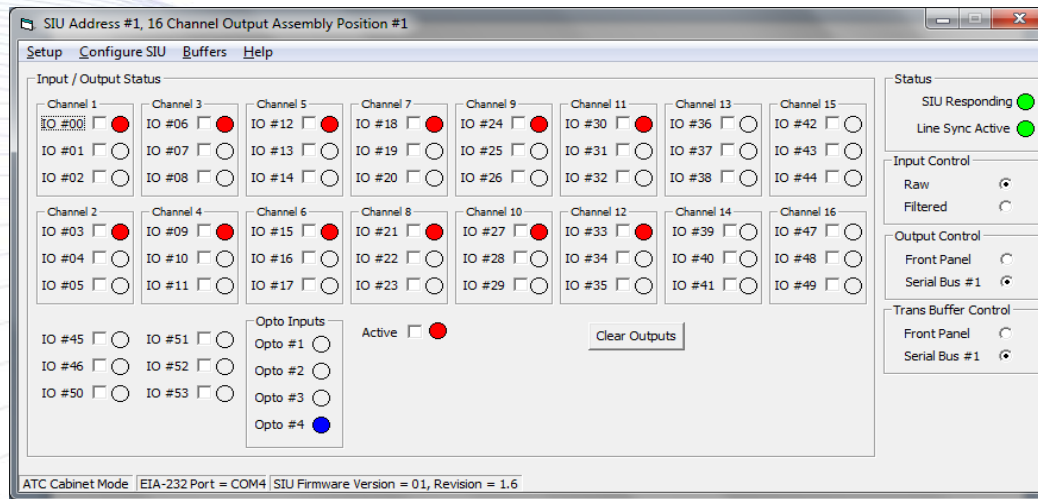

### Caution:

*This software can override the ATC commands to the SIU that are driving the HDSPs and produce signal states on the HDSP outputs that are not proper. It should only be used in a signal shop test environment.*



# Model 2216 Cabinet Power Supply

- The PS2216-2412-HV provides the dual 12/24 Vdc power to the Input and Output Assembly in high density 1U rack format.
  - 5 Amps at 24 Vdc (HDSPs, SIUs, Detectors)
  - 5 Amps at 12 Vdc (Option for Detectors)
  - 1 Amp at 48 Vdc (Cabinet Control signals, FTRs, MC, ADU2220)
- The PS2216-24-HV model provides only the 24 Vdc and 48 Vdc.
- Power Factor Corrected and very high efficiency (86%)
- LED indicators display fuse integrity.
- Integrated output protection, full NEMA temperature rated.
- Input Assembly can be operated on 12 Vdc
  - Energy savings can amount to \$1 per detector card per year when compared to 24 Vdc operation in the Input Assembly.



# Model 2217 Cabinet Power Supply

- The PS2217-HV provides the dual 48 Vdc and 24 Vdc power to the Input and Output Assembly in a compact pluggable card format.
  - 3 Amps at 24 Vdc (HDSPs, SIUs, Detectors)
  - 1 Amp at 48 Vdc (Cabinet Control signals, FTRs, MC, ADU2220)
- Power Factor Corrected and very high efficiency (86%)
- LED indicators display fuse integrity.
- Integrated output protection, full NEMA temperature rated.



# HD Flash Transfer Relay (HDFTR)

- Airtight, hermetically sealed enclosure.
- LED indicator reports actual contact status, not just input coil voltage status.
- 48 VDC powered coil
- Compact size

Model 2205

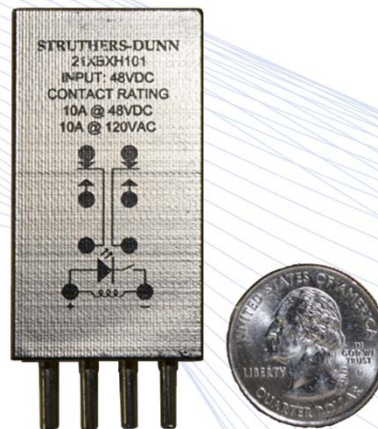

# Low Voltage ATCC

- The Low-voltage (LV) cabinet architecture is consistent with the standard high-voltage (HV) design.
- The ATC Cabinet was designed with the Low Voltage application as a target.
  - Cabinet control signals are already 48 Vdc.
  - FTR and Main Contactor coils are already 48 Vdc.
  - ADU2220 is already powered by 48Vdc.
- Substituting the -LV components and moving a few internal cabinet wires changes from 120 Vac to 48 Vdc operation.
  - CMUip-2212-LV
  - HDSP 2202-LV
  - PMU or PS2216-48-LV
- Low Voltage Safety Advantage
  - Enhanced technician touch-safer design
  - Technician licensing issues
  - Enhanced citizen safety for pole knock-down situations



# ATC Cabinet Component Overview

## Setting the Standard for Quality and Reliability

Eberle Design Inc.  
[www.EDIttraffic.com](http://www.EDIttraffic.com)