

Reno A&E
4655 Aircenter Circle
Reno, Nevada 89502
USA



Telephone: (775) 826-2020
Facsimile: (775) 826-9191
Internet: www.renoae.com
e-mail: contact@renoae.com



MODEL E/2-1500 OPERATION MANUAL Firmware Version 35.02



**Built-in
Loop Analyzer**

Four Channel Menu Driven Programmable Inductive Loop Vehicle Detector

3/26/08

This page intentionally left blank.

MODEL E/2-1500 OPERATION MANUAL

TABLE OF CONTENTS

1.0	GENERAL DESCRIPTION	5
2.0	GENERAL CHARACTERISTICS	6
2.1	Loop Frequency	6
2.2	Sensitivity Level	6
2.3	Presence / Pulse Mode	6
2.4	Call Delay Time	6
2.5	Call Extension Time	6
2.6	Max Presence Time.....	6
2.7	Option 1 - Display Loop Inductance (L).....	7
2.8	Option 2 - Display % Loop Inductance Change (- Δ L/L).....	7
2.9	Option 11 - Audible Detect Signal.....	7
3.0	SPECIFICATIONS	8
3.1	Physical	8
3.2	Electrical	8
3.3	Operational.....	8
3.4	TABLE: Sensitivity, - Δ L/L, and Response Times.....	9
3.5	TABLE: Default Settings.....	9
3.6	TABLE: Pin Assignments.....	10
4.0	USER INTERFACE.....	11
5.0	INSTALLATION AND SET-UP.....	12
5.1	Program Mode Display Screens.....	12
5.2	Normal Mode Display Screens	14
5.3	Loop Fail Indications	16
5.4	Setting Sensitivity Using the Bargraph.....	17
5.5	Setting Sensitivity for Motorcycle Detection Using the Bargraph.....	17
5.6	Full Restore To Factory Default Settings.....	18
5.7	Display Test	18
6.0	BLOCK DIAGRAM	19
7.0	THEORY OF OPERATION	20
8.0	MAINTENANCE AND TROUBLESHOOTING	21
8.1	Troubleshooting Power Problems	21
8.2	Troubleshooting Initialization Problems.....	21
8.3	Troubleshooting Loop Fail Problems	22
8.4	Troubleshooting Intermittent Loop Fail Problems.....	23
8.5	Troubleshooting Intermittent Detector Lock Ups	23
8.6	Things To Know About Loops	24

This page intentionally left blank.

1.0 GENERAL DESCRIPTION

This product manual was written for people installing, operating, and maintaining the Reno A&E Model E/2-1500 inductive loop vehicle detector. The Model E/2-1500 is a four channel, rack mount type, inductive loop vehicle detector designed to meet or exceed the 332 / 170 specification.

The Model E/2-1500 uses a microcontroller to monitor and process signals from the loop / lead-in circuits and the reset input. It uses these inputs to determine how to control the four detector channel outputs. A Liquid Crystal Display (LCD), four light emitting diodes (LEDs), and four front panel pushbuttons are used to display and program all detector functions. Several diagnostic modes are available to aid technicians and service personnel in troubleshooting detection problems.

The use of a LCD is what distinguishes this detector from that of other manufacturers. It allows more information, never before available, to be displayed to the user during normal operation of the detector. The LCD makes it easy to view and adjust all programmable detector options and settings. It is no longer necessary to check or change detector settings with DIP switches. An eight-segment bargraph at the top of the LCD can be used to provide a graphical representation of the relative change of inductance as seen by the detector at the current sensitivity level. The bargraph automatically takes into account loop size, loop inductance, number of loops, number of turns, loop geometry, lead-in length, etc. The bargraph functions as a sliding scale that relates to the programmed Sensitivity Level. The first (left-most) bargraph segment represents the minimum inductance change necessary for the detector to output a Call at the currently selected sensitivity level. Larger inductance changes will indicate more segments. Each additional segment indicates that the next sensitivity level has also been met or exceeded. When used in this manner, the bargraph provides an indication of whether the sensitivity is set too high or too low, facilitating the ideal setting of the sensitivity level.

All programmed settings are stored in non-volatile memory and can only be changed by programming new settings. Loss of power or a detector reset will not change any of the programmed settings. If a loop failure occurs, the LCD will display the type of loop failure as **L lo** (for -25% change or shorted loop conditions) or **L hi** (for +25% change or open loop conditions). Each loop failure is counted and accumulated in the Loop Failure Memory. The number of failures since the last detector reset or power interruption is very useful information during analysis of intermittent loop operation.

The Model E/2-1500 detector is a scanning detector. The scanning operation sequentially activates the ON and OFF cycle of each channel's oscillator. Since only one channel's loop(s) is (are) active at a given time, crosstalk between adjacent loops connected to the same scanning detector is minimized. The Model E/2-1500 detector's unique scanning process also disconnects the capacitors and dampens the oscillator during the off cycle. This eliminates oscillation past the OFF point (ringing or decay) every time the loop circuit is scanned which can result in crosstalk. When operating in the Program Mode, the Model E/2-1500 displays the real time loop frequency reading for each channel. The eight frequency settings can be incremented or decremented to provide precise frequency readings, removing any guesswork when changing frequency settings to eliminate crosstalk. NOTE: Adjacent loops connected to different channels of a non-scanning detector or different scanning detectors should be set to different frequencies with maximum separation.

The Reno A&E Model E/2-1500 utilizes the first major innovation in inductive loop detectors since the introduction of digital detectors. The programming of all of the detector's parameters with four normally open pushbutton switches not only simplifies setup by removing binary coded DIP switches, but also increases the reliability of the detector by eliminating the dependence on switch contacts during normal operation. The detailed descriptions displayed on the LCD eliminate the interpretation of numerous LED flash rates to determine the detector status. In addition, the Model E/2-1500 offers the versatility of software control. Special functions are possible with a simple change of the socket-mounted microprocessor. Special functions are defined as unique options (e.g. Option 2, Option 11, etc.). Special option functions are activated through the use of the LCD menu option programming.

2.0 GENERAL CHARACTERISTICS

2.1 Loop Frequency

There are eight (8) selectable loop frequency settings (normally in the range of 20 to 100 kilohertz) per channel. The actual loop operating frequency is a function of the loop / lead-in network and the components of the loop oscillator circuit. The digital display of the actual loop operating frequency for each setting makes it easy to quickly identify and eliminate crosstalk in the most difficult to configure intersections. The frequency display is typically very stable when the loop is vacant and vehicles are not passing nearby the loops. A reading that varies by more than ± 1 in the last digit is an indication of possible crosstalk between loops.

2.2 Sensitivity Level

There are nine (9) selectable sensitivity levels per channel, plus Continuous Call and Channel Off. The sensitivity levels are designed so that a one level increase actually doubles the sensitivity and a one level decrease halves the sensitivity. A unique bargraph displayed on the LCD makes it easy to quickly set sensitivity at the ideal level for any loop / lead-in network configuration. (See Section 3.4 for actual detection levels at each sensitivity level.)

CONTINUOUS CALL: When set to the Continuous Call state, the channel output is continuously in the Call state and does not count vehicles, regardless of the presence or absence of vehicles over the loop. The loop oscillator is disabled when in the Continuous Call state. This state is indicated by **CALL** flashing on the LCD. This option is selected from the Sensitivity menu in Program Mode and is useful for checking controller response and other troubleshooting activities.

CHANNEL OFF: When set to the Channel Off state, the channel output is continuously in the No Call state and does not count vehicles, regardless of the presence or absence of vehicles over the loop. The loop oscillator is disabled when in the Channel Off State. This state is indicated by **OFF** flashing on the LCD. This option is selected from the Sensitivity menu in Program Mode and is useful for checking controller response and other troubleshooting activities.

2.3 Presence / Pulse Mode

One of two mutually exclusive modes of operation for each channel is available. Presence or Pulse mode is toggled by momentarily pressing either the ▲ (UP) or ▼ (DOWN) pushbutton.

PRESENCE MODE: Provides a Call hold time of at least four minutes (regardless of vehicle size) and typically one to three hours for an automobile or truck.

PULSE MODE: An output Pulse of 125 ± 10 milliseconds duration is generated for each vehicle entering the loop detection zone. Each detected vehicle is instantly tuned out if it remains in the loop detection zone longer than two seconds. This enables detection of subsequent vehicles entering the loop detection zone. After each vehicle leaves the loop detection zone, the channel resumes full sensitivity within 0.5 seconds.

2.4 Call Delay Time

Each channel's Call Delay Time is adjustable from 0 to 255 seconds in one-second steps. Call Delay Time starts counting down when a vehicle enters the loop detection zone. The remaining Call Delay Time is continuously displayed on the LCD.

2.5 Call Extension Time

Each channel's Call Extension Time is adjustable from 0 to 25.5 seconds in 0.1-second steps. Call Extension Time starts counting down when the last vehicle clears the loop detection zone. The remaining Call Extension Time is continuously displayed on the LCD. Any vehicle entering the loop detection zone during the Call Extension Time period causes the channel to return to the Detect state, and later, when the last vehicle clears the loop detection zone, the full Call Extension Time starts counting down again.

2.6 Max Presence Time

When activated, each channel's Max Presence Time is adjustable from 1 to 999 seconds in one-second steps. A setting of **OFF** turns the Max Presence timer off. The Max Presence function is used to limit presence time by automatically resetting the channel. If this function is enabled (**ON**), the Max Presence timer begins counting down when a Call is initiated and the remaining time is continuously displayed on the LCD. If the loop becomes vacant before the Max Presence timer reaches zero, the Call is dropped and no automatic reset occurs.

2.7 Option 1 - Display Loop Inductance (L)

Each channel's Loop Inductance Display setting can be toggled **ON** or **OFF** by momentarily pressing either the ▲ (UP) or ▼ (DOWN) pushbutton. When this option is enabled (**ON**), the LCD displays the total loop inductance (actual loop inductance plus actual lead-in inductance) in microhenries for values in the range of 20 to 2500 microhenries. By recording the inductance of the loop / lead-in circuit when it is first installed, the actual inductance can be compared to the expected inductance to help identify defective loop / lead-in circuits. Loop / lead-in inductance can be easily estimated using the simple formulas included in Section 8.7 of this manual. **NOTE: Enabling this option activates it for all four channels.** This option is automatically disabled five (5) minutes after activation or on loss of power.

2.8 Option 2 - Display % Loop Inductance Change (-ΔL/L)

Each channel's Loop Inductance -ΔL/L Display setting can be toggled **ON** or **OFF** by momentarily pressing either the ▲ (UP) or ▼ (DOWN) pushbutton. When this option is enabled (**ON**), the LCD displays the percentage of inductance change (-ΔL/L value) during the Call state. To facilitate the viewing of the maximum amount of change in the -ΔL/L value while traffic is in motion over the detection zone, the channel holds the peak -ΔL/L value for a period of two seconds. **NOTE: Enabling this option activates it for all four channels.** This option is automatically disabled five (5) minutes after activation or on loss of power.

2.9 Option 11 - Audible Detect Signal

Each channel's Audible Detect Signal setting can be toggled **ON** or **OFF** by momentarily pressing either the ▲ (UP) or ▼ (DOWN) pushbutton. Only one channel can be turned **ON** at a time. Turning this option **ON** for one channel automatically turns it **OFF** for the other channel. When this option is enabled (**ON**), an audible signal is emitted as long as the detection zone is occupied (if the detector channel is set to operate in Presence Mode), or for a period of two (2) seconds (if the detector channel is set to operate in Pulse Mode). The audible signal indicates actual occupancy of the loop detection zone. Timing and disconnect functions have no effect on the audible signal. This feature allows a technician to watch the detection zone on the street and confirm correct detector operation without having to look at the detector display as well. **NOTE: This option is automatically disabled five (5) minutes after activation or on loss of power.**

3.0 SPECIFICATIONS

3.1 Physical

WEIGHT: 6 oz. (170 gm).

SIZE: 4.50 inches (11.43 cm) high x 1.12 inches (2.84 cm) wide x 6.88 inches (17.46 cm) long including connector (not including front handle). Handle adds 1.00 inch (2.54 cm) to depth measurement.

OPERATING TEMPERATURE: -40° F to +180° F (-40° C to +82° C).

CIRCUIT BOARD: Printed circuit boards are 0.062 inch thick FR4 material with 2 oz. copper on both sides and plated through holes. Circuit board and components are conformal coated with polyurethane.

CONNECTOR: 2 x 22 pin edge card connector with 0.156-inch (0.396 cm.) contact centers. Key slots located between pins B / 2 & C / 3, E / 5 & F / 6, and M / 11 & N / 12.

3.2 Electrical

POWER: 10.8 to 14 VDC, 100 mA maximum, 40 mA during normal operation.

LOOP INDUCTANCE RANGE: 20 to 2500 microhenries with a Q factor of 5 or greater.

LOOP INPUTS: Transformer isolated. The minimum capacitance added is 0.068 microfarad.

LIGHTNING PROTECTION: Each channel can tolerate, without damage, a 10 microfarad capacitor charged to 2,000 volts being discharged directly into the loop input terminals, or a 10 microfarad capacitor charged to 2,000 volts being discharged between either loop terminal and earth ground.

RESET: Application of a 30-millisecond low state (0 to 8 VDC) to Pin C resets the detector. Each detector channel can be independently reset by pressing the **CHAN** pushbutton until the desired channel is selected, then pressing and holding the **CHAN** pushbutton for three seconds. Also, changing either the sensitivity or loop frequency of a channel will reset that channel.

FAIL-SAFE OUTPUTS: Conducting state indicates detection output. Each detector channel output defaults to a Call for any loop failure condition. In the case of power loss, the outputs will indicate the non-conducting state, or no detection.

SOLID STATE OUTPUT RATING: All outputs are independent open-drain FET's with source tied to DC Common (Pin A). 30 VDC maximum drain to source. 50 mA maximum on state current. 0.1 VDC maximum transistor saturation voltage. The output is protected with a 33-volt Zener diode connected between the drain and source.

3.3 Operational

DISPLAY: The LCD backlighting illuminates whenever any pushbutton is pressed. The backlighting will extinguish five (5) minutes after the last pushbutton press.

DETECT / FAIL INDICATORS: Each channel has a super bright, high intensity, red light emitting diode (LED) to indicate a Call output, Delay Timing, Extension Timing, or Failed Loop condition. A continuous ON state indicates a Call output. Delay Timing is indicated by a four Hz flash rate with 50% duty cycle (125 ms ON, 125 ms OFF). Extension Timing is indicated by a 16.6 Hz flash rate with 50% duty cycle (30 ms ON, 30 ms OFF). A flash rate of three 50 millisecond pulses indicates a prior loop failure condition. **NOTE: To conserve power, the four, front panel mounted channel Detect / Fail LEDs are disabled five (5) minutes after the last actuation of any front panel pushbutton. Pressing any front panel pushbutton will reactivate the LEDs.**

RESPONSE TIME: Response time is measured from the point when the vehicle enters the loop until the detector output transitions to the detect state.(See Section 3.4 for actual response times).

SELF-TUNING: The detector automatically tunes and is operational within two seconds after application of power or after being reset. Full sensitivity and hold time require 30 seconds of operation.

ENVIRONMENTAL AND TRACKING: The detector is fully self-compensating for environmental changes and loop drift over the full temperature range and the entire loop inductance range.

GROUNDING LOOP OPERATION: The loop isolation transformer allows operation with poor quality loops (which may include one short to ground at a single point).

LOOP FEEDER LENGTH: Up to 5000 feet (1500 m) maximum with proper feeder cable and appropriate loops.

LOOP (FAIL) MONITOR: If the total inductance of the channel's loop input network goes out of the range specified for the detector, or rapidly changes by more than $\pm 25\%$, the channel will immediately enter the Fail-Safe mode and display **LOOP FAIL** on the LCD. The type of loop failure will also be displayed as **L lo** (for -25% change or shorted loop conditions) or **L hi** (for $+25\%$ change or open loop conditions). This will continue as long as the loop fault exists. *However, if the detector is reset, or power is momentarily lost, the detector will retune if the loop inductance is within the acceptable range. If any type of loop failure occurs in one (or more) loop(s) in a group of two or more loops wired in parallel, the detector will not respond with a Fail-Safe output following any type of reset. It is essential that multiple loops wired to a common detector channel always be wired in series to ensure Fail-Safe operation under all circumstances.* At the time of a loop failure, the channel's LED will begin to flash at a rate of three flashes per second. The LED will continue this display pattern until the channel is manually reset or power is removed. If the loop self-heals, the **LOOP FAIL** message on the LCD will extinguish and the channel will resume operation in a normal manner; except the LED will continue the three flashes per second display pattern, thus providing an alert that a prior Loop Fail condition has occurred. Each loop failure for the channel is counted and accumulated into the Loop Fail Memory. The total number of loop failures written into the Loop Fail Memory (since the last power interruption or manual reset) is viewed by stepping through the channel's functions in Program Mode until the **LOOP FAIL** message is displayed.

3.4 TABLE: Sensitivity, $-\Delta L/L$, and Response Times

Sensitivity	$-\Delta L/L$	Response Time
OFF	-----	-----
1	0.64%	35 \pm 7 ms
2	0.32%	35 \pm 7 ms
3	0.16%	35 \pm 7 ms
4	0.08%	35 \pm 7 ms
5	0.04%	35 \pm 7 ms
6	0.02%	48 \pm 10 ms
7	0.01%	79 \pm 17 ms
8	0.005%	138 \pm 28 ms
9	0.0025%	261 \pm 51 ms
CALL	-----	-----

NOTE: Entries in this table are based on the assumption that all four channels are set to the same sensitivity. To approximate response time for a detector with the channels set to different sensitivities, look up the response time for each channel and divide it by four, then add these times together.

3.5 TABLE: Default Settings

Function	Channel 1	Channel 2	Channel 3	Channel 4
Loop Frequency	2	4	6	8
Sensitivity Level	4	4	4	4
Presence / Pulse Mode	Presence	Presence	Presence	Presence
Call Delay Time	0	0	0	0
Call Extension Time	0.0	0.0	0.0	0.0
Max Presence Time	OFF	OFF	OFF	OFF
Option 1 - Display Loop Inductance (L)	OFF	OFF	OFF	OFF
Option 2 - Display % Loop Inductance Change ($-\Delta L/L$)	OFF	OFF	OFF	OFF
Option 11 - Audible Detect Signal	OFF	OFF	OFF	OFF

3.6 TABLE: Pin Assignments

2 X 22 Pin Edge Card Connector

Pin	Function	Pin	Function
A	DC Common	1	No Connection
B	DC +	2	No Connection
C	Reset Input	3	No Connection
D	Channel 1 Loop Input	4	Channel 1 Loop Input
E	Channel 1 Loop Input	5	Channel 1 Loop Input
F	Channel 1 Output, Drain	6	No Connection
H	No Connection	7	No Connection
J	Channel 2 Loop Input	8	Channel 2 Loop Input
K	Channel 2 Loop Input	9	Channel 2 Loop Input
L	Chassis Ground	10	No Connection
M	No Connection	11	No Connection
N	No Connection	12	No Connection
P	Channel 3 Loop Input	13	Channel 3 Loop Input
R	Channel 3 Loop Input	14	Channel 3 Loop Input
S	Channel 3 Output, Drain	15	No Connection
T	No Connection	16	No Connection
U	Channel 4 Loop Input	17	Channel 4 Loop Input
V	Channel 4 Loop Input	18	Channel 4 Loop Input
W	Channel 2 Output, Drain	19	No Connection
X	No Connection	20	No Connection
Y	Channel 4 Output, Drain	21	No Connection
Z	No Connection	22	No Connection

4.0 USER INTERFACE

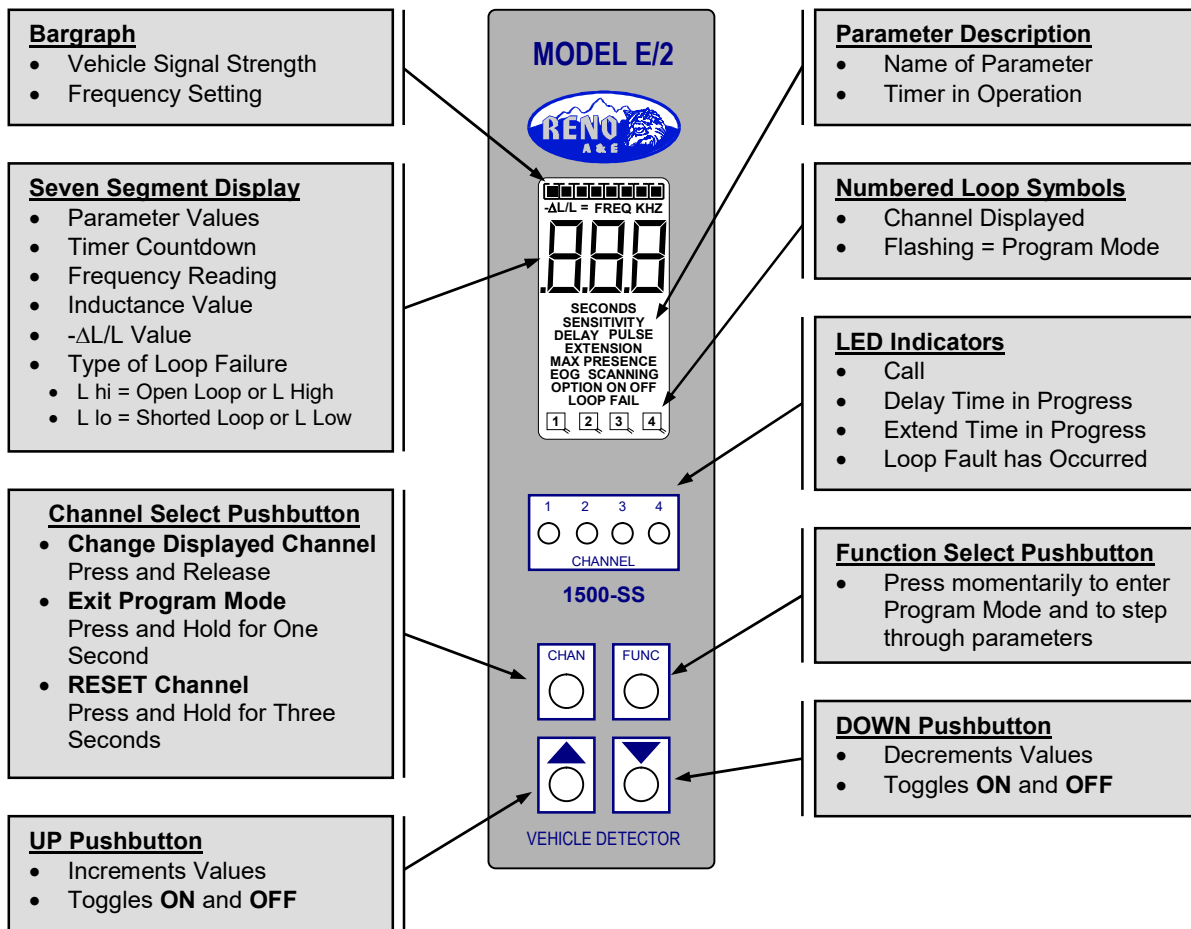

NOTE: There are no internal switches or jumpers to set.

5.0 INSTALLATION AND SET-UP

The detector has no DIP switches or jumpers to configure. Plug the detector into an appropriately wired rack and apply power. If the detector is not new from the factory, it may be advantageous to reset the detector back to the factory defaults to avoid having to check every setting for each channel. To reset the detector to factory default, press and hold all four pushbutton switches simultaneously for five seconds. When all four pushbuttons are depressed, the display will start counting down from five (5). When the countdown reaches zero (0), releasing the pushbuttons will reload the factory defaults and reset all channels.

All operating parameters can be adjusted from the front panel. The detector continues to operate normally while it is in the Program Mode. The value currently displayed is always the actual value being used. Example: If you are changing the delay time, the time displayed at the instant that a vehicle entered the detection zone for that channel would be the value used for the delay timer.

Pressing the **FUNC** pushbutton enters the Program Mode. The **FUNC** pushbutton has an auto repeat function. This allows quick navigation to the desired parameter. The **FUNC** pushbutton only moves forward through all of the parameters. There is no way to move backwards through the parameters.

While viewing any parameter, pressing the **CHAN** pushbutton will display the same parameter for the next channel. The currently selected channel is indicated at the bottom of the LCD.

Pressing and holding either the **▲** (UP) or **▼** (DOWN) pushbutton will cause the value to change rapidly until the pushbutton is released.

Pressing and holding the **CHAN** pushbutton for one second will exit the Program Mode and return to the Normal Mode.

NOTE: To conserve power, the four, front panel mounted channel Detect / Fail LEDs are disabled five (5) minutes after the last actuation of any front panel pushbutton. Pressing any front panel pushbutton will reactivate the LEDs.

5.1 Program Mode Display Screens



PARAMETER Loop Frequency.
SETTINGS..... Eight (8) Selections - 1 to 8.
SETTING DISPLAYED Bargraph indicates settings from 1 (left) to 8 (right).
7 SEGMENT DISPLAY Actual Frequency of the loop circuit. Typically 20.0 to 99.9 kilohertz.
DEFAULT SETTING Channel 1 = 2, Channel 2 = 4, Channel 3 = 6, Channel 4 = 8.
EXAMPLE Frequency setting 4 is selected for channel 1. The loop frequency is 34.9 kHz.
NOTES..... Changing the frequency will reset the channel. An unstable frequency display varying more than ± 0.2 kilohertz may indicate loop crosstalk or other interference.



PARAMETER Sensitivity Level.
SETTINGS..... 11 Selections - 1 to 9, OFF, or CALL.
SETTING DISPLAYED 7-segment display will show the currently selected setting.
7 SEGMENT DISPLAY Currently selected Sensitivity.
DEFAULT SETTING 4 for all channels.
EXAMPLE Sensitivity 5 is selected for channel 1.
NOTES..... Changing the sensitivity will reset the channel. If the channel is in the Call state when viewing this parameter, the bargraph will show the strength of vehicle Calls so that the correct sensitivity can be verified from this screen.

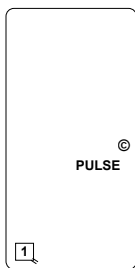

PARAMETER Presence / Pulse Mode.
SETTINGS..... Presence or Pulse.
SETTING DISPLAYED The word PRESENCE or PULSE will be displayed.
7 SEGMENT DISPLAY Blank.
DEFAULT SETTING Presence for all channels.
EXAMPLE Pulse Mode is selected for channel 1.
NOTES..... If the channel is in the Call state when this parameter is changed, the change will not take effect until the detection zone is empty or the channel is reset.



PARAMETER Call Delay Time.
SETTINGS..... 256 Selections - 0 to 255 Seconds in one-second steps.
SETTING DISPLAYED 7-segment display will show the currently selected setting.
7 SEGMENT DISPLAY Currently selected Delay time in seconds.
DEFAULT SETTING 0 seconds for all channels.
EXAMPLE Delay of 10 seconds selected for channel 1.
NOTES..... If the channel's detection zone is occupied when this parameter is changed, the change will not take effect until the detection zone is empty or the channel is reset.



PARAMETER Call Extension Time.
SETTINGS..... 256 Selections - 0 to 25.5 Seconds in 0.1-second steps.
SETTING DISPLAYED 7-segment display will show the currently selected setting.
7 SEGMENT DISPLAY Currently selected Extension time in seconds.
DEFAULT SETTING 0 seconds for all channels.
EXAMPLE Extension of 2.5 seconds selected for channel 1.
NOTES..... If the channel's detection zone is occupied when this parameter is changed, the change will take effect immediately.



PARAMETER Max Presence Time.
SETTINGS..... 1000 Selections - 1 second to 999 seconds or OFF.
SETTING DISPLAYED 7-segment display will show currently selected setting.
7 SEGMENT DISPLAY Currently selected Max Presence time in seconds.
DEFAULT SETTING OFF for all channels.
EXAMPLE Max Presence is turned OFF for channel 1.
NOTES..... If the channel's detection zone is occupied when this parameter is changed, the change will not take effect until the detection zone is empty or the channel is reset.

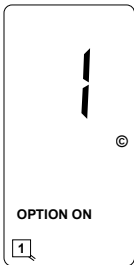

PARAMETER Option 1 - Display Loop Inductance (L).
SETTINGS..... ON or OFF.
SETTING DISPLAYED The word ON or OFF will be displayed.
7 SEGMENT DISPLAY The number of this option.
DEFAULT SETTING OFF for all channels.
EXAMPLE Option 1 is turned ON for all channels.
NOTES..... This option is a detector wide setting. Changing it for one channel changes it for all channels. This option will automatically turn off five (5) minutes after being activated or on loss of power.

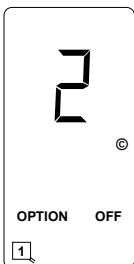

PARAMETER Option 2- Display % Loop Inductance Change (-ΔL/L).
SETTINGS..... ON or OFF.
SETTING DISPLAYED The word ON or OFF will be displayed.
7 SEGMENT DISPLAY The number of this option.
DEFAULT SETTING OFF for all channels.
EXAMPLE Option 2 is turned OFF for all channels.
NOTES..... This option is a detector wide setting. Changing it for one channel changes it for all channels. This option will automatically turn off five (5) minutes after being activated or on loss of power.

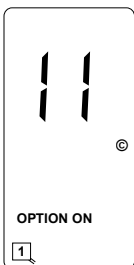

PARAMETER Option 11 - Audible Detect Signal.
SETTINGS..... ON or OFF.
SETTING DISPLAYED The word ON or OFF will be displayed.
7 SEGMENT DISPLAY The number of this option.
DEFAULT SETTING OFF for all channels.
EXAMPLE Option 11 is turned ON for channel 1.
NOTES..... This option is mutually exclusive with the same option on the other channels. Turning it ON for one channel turns it OFF for the other channels. This option will automatically turn OFF five (5) minutes after being activated or on loss of power.

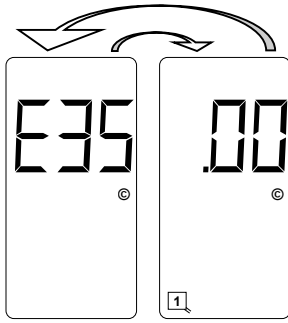

PARAMETER Firmware Version and Revision.
SETTINGS View Only.
SETTING DISPLAYED..... View Only.
7 SEGMENT DISPLAY Model letter and firmware version on one screen and firmware revision on the other screen.
DEFAULT SETTING Not Applicable.
EXAMPLE Model E firmware version 35, revision .00.

5.2 Normal Mode Display Screens

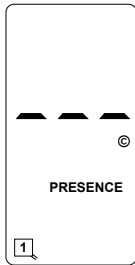

STATE Idle.
BARGRAPH DISPLAY OFF.
7 SEGMENT DISPLAY Three Dashes.
TEXT PULSE or PRESENCE indicating detection mode of the channel.
CHANNEL LED OFF.
CHANNEL OUTPUT OFF.
EXAMPLE Channel 1 is idle and in the presence mode of detection.
NOTES..... This is the normal state for the display when the loop detection zone is unoccupied and the channel does not have any timing options set.



STATE Presence Call.
BARGRAPH DISPLAY Number of sensitivity levels that the inductance change caused by the vehicle exceeds the detection threshold (first dot = current sensitivity level, second dot = next lower sensitivity level, etc.).
7 SEGMENT DISPLAY Call.
TEXT PRESENCE, indicating detection mode of the channel.
CHANNEL LED Solid ON.
CHANNEL OUTPUT ON.
EXAMPLE Channel 1 detection zone is occupied by a vehicle that exceeds the detection threshold by four (4) sensitivity levels and channel 1 is outputting a Call.

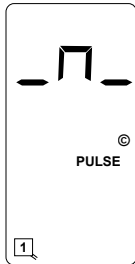

STATE Pulse Call.
BARGRAPH DISPLAY OFF.
7 SEGMENT DISPLAY -¹- for 125 milliseconds.
TEXT PULSE, indicating detection mode of the channel.
CHANNEL LED ON for 125 milliseconds.
CHANNEL OUTPUT ON for 125 milliseconds.
EXAMPLE Channel 1 detection zone is occupied and channel 1 is outputting a Call of 125 milliseconds duration.
NOTES..... This display is only shown for 125 milliseconds (the duration of the pulse output).



STATE Timing Delay.
BARGRAPH DISPLAY Number of sensitivity levels that the inductance change caused by the vehicle exceeds the detection threshold (first dot = current sensitivity level, second dot = next lower sensitivity level, etc.).
7 SEGMENT DISPLAY Countdown of remaining Delay time (in seconds).
TEXT SECONDS, DELAY, and PULSE or PRESENCE.
CHANNEL LED Four Hz flash rate with 50% duty cycle (125 ms ON, 125 ms OFF).
CHANNEL OUTPUT OFF.
EXAMPLE Channel 1 detection zone is occupied by a vehicle that exceeds the detection threshold by two (2) sensitivity levels, there are three (3) seconds of Delay remaining, and channel 1 is not outputting a Call.



STATE Timing Extension.
BARGRAPH DISPLAY OFF.
7 SEGMENT DISPLAY Countdown of remaining Extension time (in seconds).
TEXT SECONDS, EXTENSION, and PULSE or PRESENCE.
CHANNEL LED 16.6 Hz flash rate with 50% duty cycle (30 ms ON, 30 ms OFF).
CHANNEL OUTPUT ON.
EXAMPLE Channel 1 detection zone is vacant, there are two and one-half (2.5) seconds of Extension time remaining, and channel 1 is outputting a Call.



STATE Timing Max Presence.
BARGRAPH DISPLAY Number of sensitivity levels that the inductance change caused by the vehicle exceeds the detection threshold (first dot = current sensitivity level, second dot = next lower sensitivity level, etc.).
7 SEGMENT DISPLAY Countdown of remaining seconds of Max Presence.
TEXT SECONDS and MAX PRESENCE.
CHANNEL LED Solid ON.
CHANNEL OUTPUT ON.
EXAMPLE Channel 1 detection zone is occupied by a vehicle that exceeds the detection threshold by five (5) sensitivity levels, there are 30 seconds of Max Presence remaining, and channel 1 is outputting a Call.



STATE Display Loop Inductance (L) (Option 1 ON).
BARGRAPH DISPLAY OFF if no vehicle is detected. Number of sensitivity levels that the inductance change caused by the vehicle exceeds the detection threshold (first dot = current sensitivity level, second dot = next lower sensitivity level, etc.) if a vehicle is detected.
7 SEGMENT DISPLAY Loop / Lead-In circuit inductance in microhenries. If the value exceeds 999, the display will alternate between the thousands place (1 or 2) and the lower three digits of the inductance value.
TEXT L=
CHANNEL LED The detect LED operates normally indicating Call, No Call, delay, and/or extension as expected.
CHANNEL OUTPUT The channel output operates normally.
EXAMPLE Channel 1 Loop / Lead-In circuit inductance is 98 microhenries and channel 1 is not detecting a vehicle.
NOTES If Option 2, Display % Loop Inductance Change (-ΔL/L) is ON, this display is only visible when the channel is not detecting a vehicle.



STATE Display % Loop Inductance Change (-ΔL/L) (Option 2 ON).
BARGRAPH DISPLAY OFF.
7 SEGMENT DISPLAY Percentage of change in inductance of the Loop / Lead-In circuit.
TEXT -ΔL/L.
CHANNEL LED The detect LED operates normally indicating Call, No Call, delay, and/or extension as expected.
CHANNEL OUTPUT The channel output operates normally.
EXAMPLE Percentage change of inductance of the Call on channel 1 is 0.087%.
NOTES This display is only visible while the channel is detecting a vehicle and not timing any functions.



STATE LCD Test.
BARGRAPH DISPLAY All segments on.
7 SEGMENT DISPLAY All segments on.
TEXT All segments on.
CHANNEL LED The detect LED operates normally indicating Call, No Call, delay, extension, and/or pending as expected.
CHANNEL OUTPUT The channel output operates normally.
EXAMPLE All segments on.
NOTES This display is visible whenever two or three pushbutton switches are pressed at the same time.

5.3 Loop Fail Indications

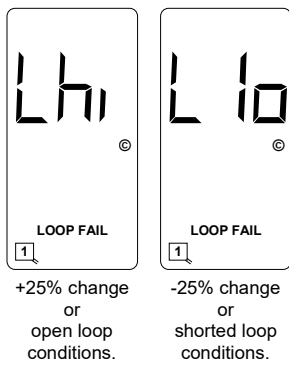

If the total inductance of a channel's loop input network goes out of the range specified for the detector, or rapidly changes by more than $\pm 25\%$, the channel will enter the Fail-Safe mode and **LOOP FAIL** will be displayed on the LCD. The type of loop failure will also be displayed as **L lo** (for -25% change or shorted loop conditions) or **L hi** (for +25% change or open loop conditions). This will continue as long as the loop fault exists. Fail-Safe mode generates a continuous call in Presence Mode and in Pulse Mode. At the time of a loop failure, the channel's LED will begin to flash at a rate of three flashes per second. The LED will continue this display pattern until the channel is manually reset or power is removed.

If the loop self-heals, the **LOOP FAIL** message on the LCD will extinguish and the channel will resume operation in a normal manner; except, the LED will continue the three flashes per second display pattern, thus, providing an alert that a prior Loop Fail condition has occurred. Each loop failure is counted and accumulated into the Loop Fail Memory. The total number of loop failures for the channel is written into the Loop Fail Memory (since the last power interruption or manual reset) and can be seen by stepping through the channel's functions in Program Mode to the **LOOP FAIL** display.

This feature is a very useful tool that can be utilized to identify intermittent loop problems. If the count is extremely high for the period of time observed, the problem is very likely a loose connection (check for loose connections at the terminal strip and bad splices in the field). The Loop Fail Count is reset when power is removed from the detector. This prevents the Loop Failure Count from moving to another loop, if the detector is moved to a new location.

To view the Loop Fail Count, repeatedly press the **FUNC** pushbutton until the **LOOP FAIL** display is shown. The Loop Fail Count display is after the **OPTION** displays. Pressing the **▲** (UP) or **▼** (DOWN) pushbutton while the Loop Fail Count is displayed will reset the count to zero.

NOTE: The Loop Fail Count is not reset when the channel's sensitivity or frequency is changed. The prior Loop Fail indication will continue until the Loop Fail Count is reset to zero.

5.4 Setting Sensitivity Using the Bargraph

The bargraph is a graphical representation of the relative change of inductance as seen by the channel. It automatically takes into account the channel's sensitivity setting, loop geometry, configuration, lead-in length, etc. The first bar segment represents the minimum inductance change (set by the sensitivity level) necessary for the channel to output a call. Each additional segment to the right represents the inductance change in excess of the next sensitivity threshold. Usually, the larger the vehicle, the greater the $-\Delta L/L$; thus, more and more segments are displayed. The bargraph can be used as a precise indicator to select the proper sensitivity level.

The bargraph below shows the deflection (3 segments) of a vehicle with Sensitivity set to Level 4. The vehicle in the loop zone is causing a change of inductance greater than 0.32% $-\Delta L/L$ or Sensitivity Level 2.



The bargraph below has the same vehicle in the loop zone causing the same inductance change as above. Since the sensitivity setting was increased to Level 7, six segments are now displayed. If the bargraph displays 5 or 6 segments for a vehicle in the loop and motorcycles are not a concern, the sensitivity has been set to the proper range.

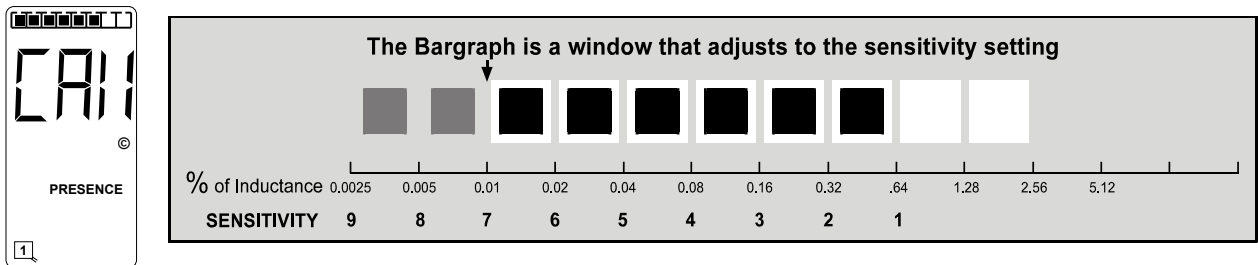

5.5 Setting Sensitivity for Motorcycle Detection Using the Bargraph

The bargraph can also be used to select the proper sensitivity level for small motorcycle detection. The relative change of inductance caused by a motorcycle and a single automobile are proportional on any loop configuration. Selecting the sensitivity level that causes the bargraph to display the seventh segment for a single standard automobile automatically sets the sensitivity to detect small motorcycles. Follow the steps below:

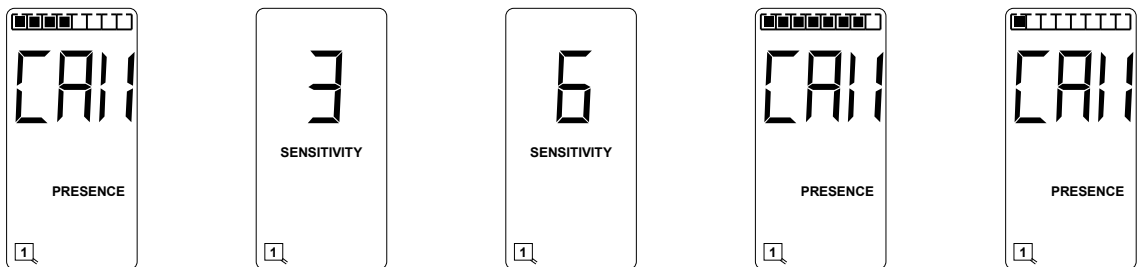

Step 1: Observe a single standard automobile in the loop zone. Note the number of segments displayed on the bargraph. (4)

Step 2: Go to the Program mode. Note the sensitivity level. (3)

Step 3: Subtract the actual number of segments displayed from the desired number of 7. ($7 - 4 = 3$) Increase the sensitivity three levels.

Step 4: Verify that a single standard automobile causes the bargraph to move seven segments.

Step 5: A small motorcycle should be detected causing a one segment deflection.

Note: This method applies to conventional loop configurations only. Other loop configurations, such as Quadrupole, will require a different method to correctly set sensitivity for motorcycle detection. Increasing the sensitivity to detect motorcycles in some loop configurations will make the loop sensitive to adjacent lane detection.

5.6 Full Restore To Factory Default Settings

Pressing all four front panel switches simultaneously and continuously for five (5) seconds resets the detector and restores all the factory default settings. The countdown of the five second period is displayed on the LCD. Releasing any of the switches before the countdown ends aborts the Full Restore operation. (See Section 3.5 for default settings.)

5.7 Display Test

Pressing any two or three of the front panel switches simultaneously will turn on all possible symbols and messages on the LCD.

6.0 BLOCK DIAGRAM

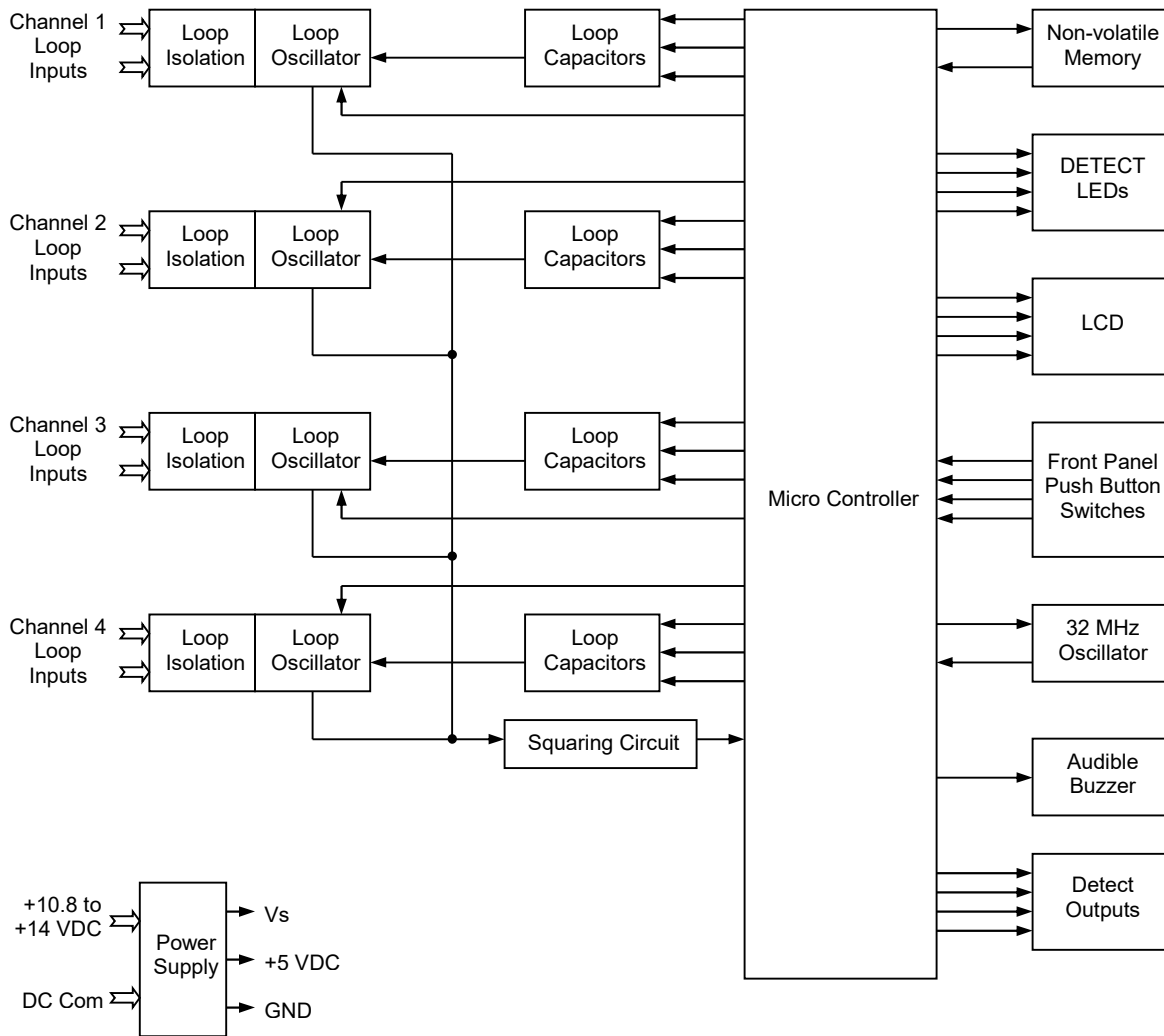

7.0 THEORY OF OPERATION

The Reno A&E Model E/2-1500 detector digitally measures changes in the resonant frequency of four independent loop circuits to determine if a vehicle has entered the detection zone. The Model E/2-1500 detector applies an excitation voltage to each loop circuit resulting in the loops oscillating at their resonant frequency. The current flow in the loop wire creates magnetic fields around the loop wire. When a vehicle passes over the loop area, the conductive metal of the vehicle causes a loading of the loop's magnetic fields. The loading decreases the loop inductance, which causes the resonant frequency to increase. By continuously sampling the loop's resonant frequency, the magnitude and rate of change can be determined. If the frequency change exceeds a selectable threshold (set by the sensitivity settings), the channel will activate an output signal. If the rate of change is slow, typical of environmental drift, the channel will continuously track and compensate for the change. The Model E/2-1500 detector also monitors the loop frequency for out of range conditions such as an open or shorted loop circuit.

The Model E/2-1500 detector is a scanning detector. The scanning method sequentially turns each channel's loop oscillators on and off. Each channel's oscillator circuit supplies the excitation voltage that is coupled to the loop circuit by a loop isolation transformer. The channel's oscillator circuit supplies the excitation voltage that is coupled to the loop circuit by a loop isolation transformer. The transformer provides high common mode isolation between the loop and detector electronics, which allows the channel to operate on poor quality loops including a single short to ground. The transformer also limits the amount of static energy (lightning) that can transfer to the detector electronics. A spark gap transient suppression device is connected across the loop inputs connected to the isolation transformer. This device dissipates static charges before they reach the transformer. A network of four capacitors is connected to the detector side of the isolation transformer. Three of the capacitors can be switched in or out of the oscillator circuit to shift the frequency of the loop oscillator circuit thus providing frequency separation between adjacent loops. The three switchable capacitors are electronically switched using FETs and are selected when programming parameter values with the front panel pushbutton switches.

The outputs from the four loop oscillators are tied together and fed into a common squaring circuit. This is possible since the detector is a scanning detector that allows only a single loop oscillator to be operating at any given time. The sine wave from the loop oscillator circuit is squared to provide a precise zero crossing signal for the input to the microcontroller. This signal is called the loop sample. The loop sample is an integral number of complete oscillations from the loop oscillator circuit. The number of loop oscillations counted is a function of the selected sensitivity setting for the channel. The required number of loop oscillations needed for a loop sample increases as the sensitivity setting is increased. The microcontroller uses the period of the loop sample for accumulating high-speed (32 MHz) crystal clock pulses generated by the microcontroller's internal high-speed crystal oscillator. The number of crystal clock pulses accumulated during consecutive loop samples is compared to the internal reference number of crystal clock pulses stored in the microcontroller's memory.

When a vehicle enters the loop zone the loop inductance decreases. This decrease in loop inductance causes an increase in the loop oscillator frequency. In turn, an increase in loop oscillator frequency results in a decrease of the time period for the loop sample. Hence, when a vehicle enters the loop zone the number of crystal clock pulses accumulated during a loop sample period decreases. By comparing the new count with the reference count, a percentage change can be calculated that indirectly relates to the inductance change. If the magnitude of the change exceeds a selectable threshold (sensitivity setting), the channel activates an output device. The rate of change is also monitored. Slow rates of change caused by environmental fluctuations are tracked and automatically compensated for.

The microcontroller uses the high-speed crystal clock count to calculate the loop inductance, frequency and percentage of change. If selected, the values are displayed on the seven segment LCD. The microcontroller also processes the pushbutton switch selections for the LCD and stores the operating parameters in non-volatile memory. Stored parameters are only changed with the front panel switches and are unaffected by loss of power or channel reset. The microcontroller continuously processes the loop samples and the detector operation is not affected during the operation of the switches or the LCD. (Note: When either channel's sensitivity or frequency is changed, that channel is reset.)

In addition, the microcontroller conditions the outputs based on the programmed settings of the various timers (Delay, Extension, and Max Presence).

8.0 MAINTENANCE AND TROUBLESHOOTING

The Reno A&E Model E/2-1500 Detector requires no maintenance. If you are having problems with your Model E/2-1500 detector, use the troubleshooting chart below to help determine the cause of the problem.

Symptom	Where To Start
No LCD display and no LEDs lit.	See Troubleshooting Power Problems.
LCD displays garbage and detector does not respond to button presses.	See Troubleshooting Initialization Problems.
Detector does not respond to button presses.	See Troubleshooting Initialization Problems.
LCD continually displays L lo and LOOP FAIL or L hi and LOOP FAIL.	See Troubleshooting Loop Fail Problems.
The channel detect LED is flashing three times per second and channel appears to be working correctly.	See Troubleshooting Intermittent Loop Fail Problems.
Detector intermittently stays in the Call state.	See Troubleshooting Intermittent Channel Lock Ups.
LCD always displays a flashing Call.	The sensitivity for the channel has been set to Call forcing the channel to output a constant call.

8.1 Troubleshooting Power Problems

Does the LCD display anything when the detector is powered up?

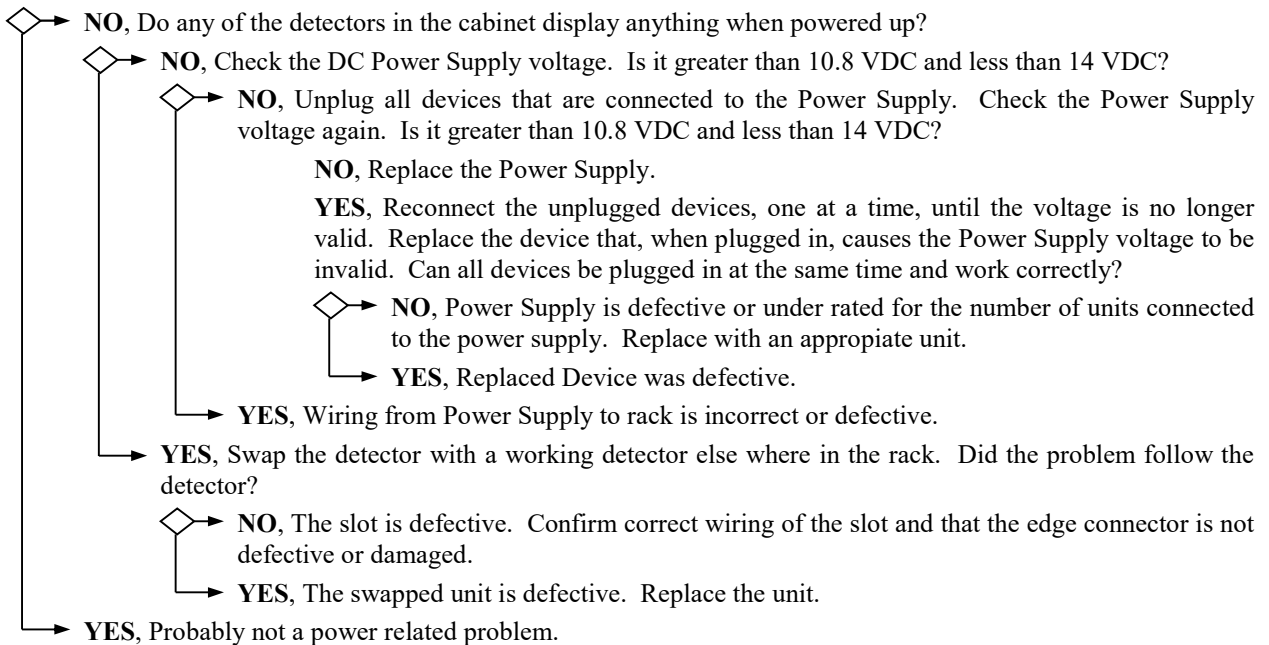

8.2 Troubleshooting Initialization Problems

Does the LCD display the Model and Firmware version when powered up?

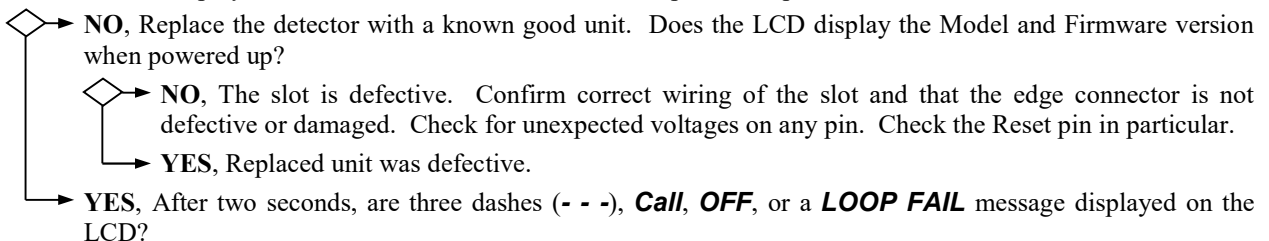

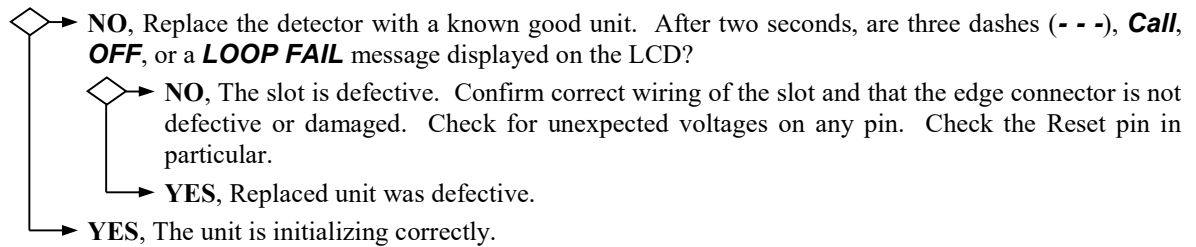

8.3 Troubleshooting Loop Fail Problems

Check each channel's status by momentarily pressing the CHAN button to step through the channels. Do any of the channels display **L hi** and **LOOP FAIL**?

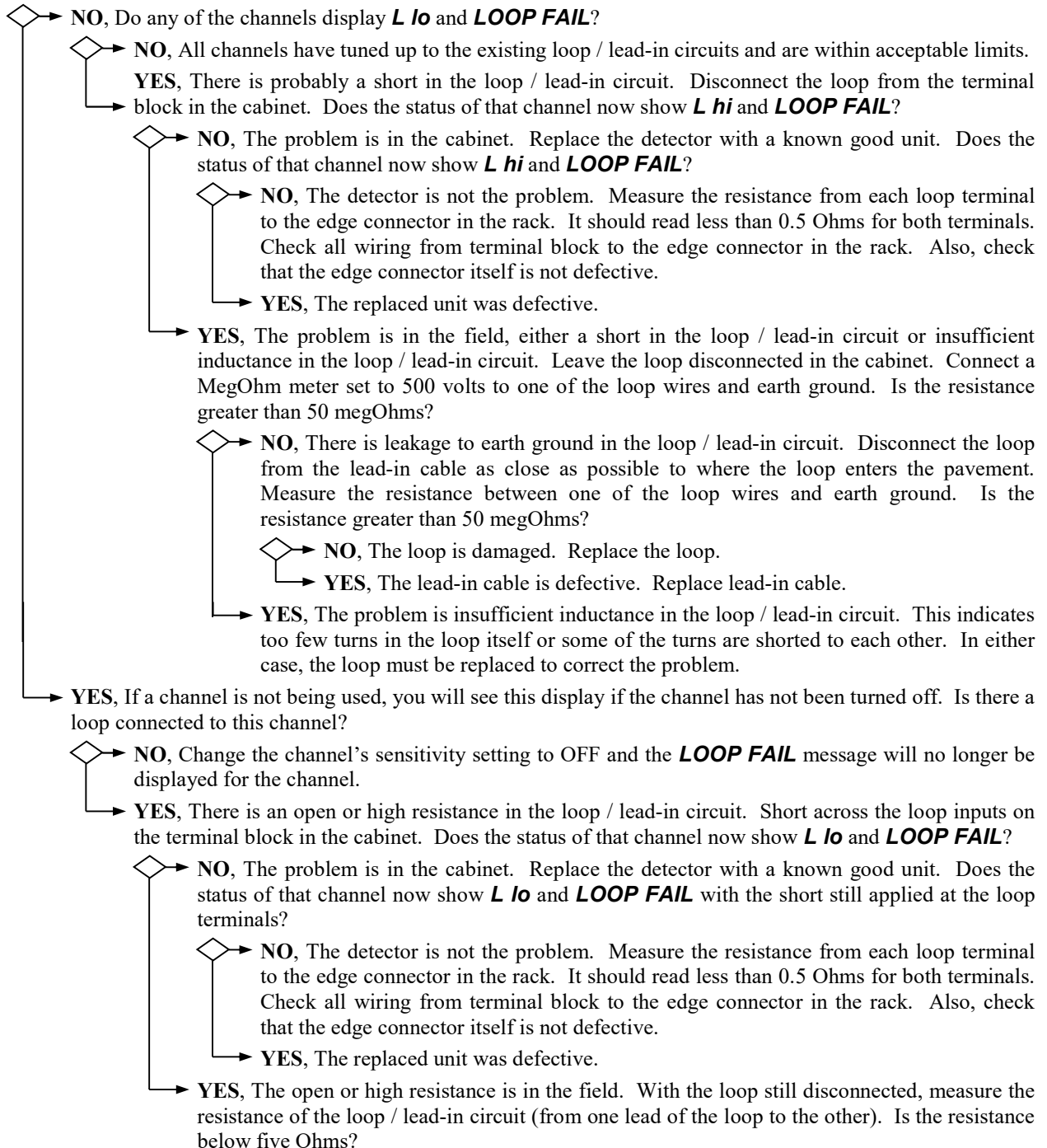

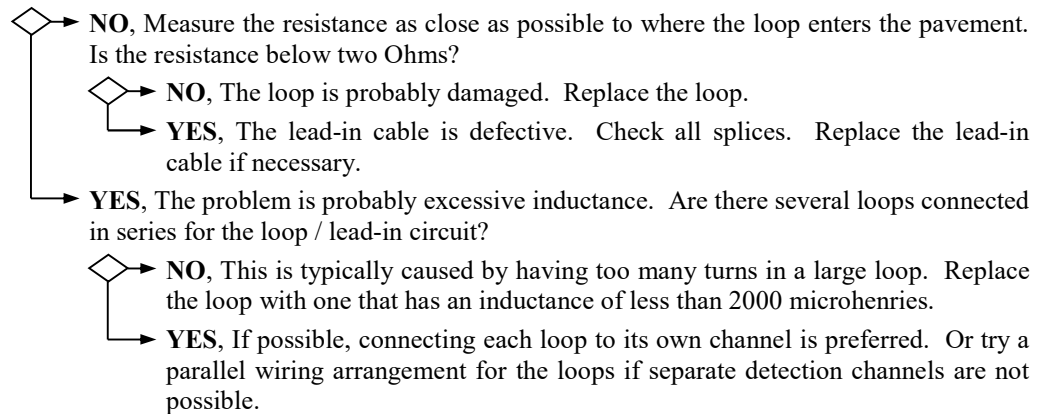

8.4 Troubleshooting Intermittent Loop Fail Problems

Have you been able to see the channel display while the loop failure was occurring?

NO, Loop Fail problems tend to be bad splices in the loop / lead-in circuit, shorts in the loop / lead-in circuit, shorts to earth ground in the loop / lead-in circuit, or loose connections or bad solder joints in the signal cabinet. If you have any splices that are not soldered and sealed with an adhesive heat shrink or epoxy resin, replace the splice with one that is. Using a MegOhm meter, measure the resistance from one of the loop wires to earth ground. It should be greater than 50 megOhms. Inspect the loop. Look for exposed wires or debris pressed into the saw cut. Tighten all screw terminals in the signal cabinet that the loop circuit uses. Check solder joints in the loop circuit, especially on the harness itself. Disconnect and reconnect any connector used in the loop circuit and check for loose pins and sockets in these connectors. If your cabinet has lightning or surge suppression devices on the loop inputs in the cabinet, remove or replace them. Check for places in the field where the loop wire or lead-in cable may be pinched or chaffed. Look for wires pinched under junction box covers and where the wire enters a conduit, especially where the loop wire leaves the saw cut and enters a conduit. After checking all of the above items, you could swap out the detector but this type of failure is rarely ever related to the detector.

YES, Did the display show **L hi**?

NO, In this case, the display must have been **L lo**. This indicates an intermittent shorted loop or -25% inductance change. Using a MegOhm meter, measure the resistance from one of the loop wires to earth ground. It should be greater than 50 megOhms. Inspect the loop. Look for exposed wires or debris pressed into the saw cut. Check for places in the field where the loop wire or lead-in cable may be pinched or chaffed. Look for wires pinched under junction box covers and where the wire enters a conduit, especially where the loop wire leaves the saw cut and enters a conduit. **If your cabinet has lightning or surge suppression devices on the loop inputs in the cabinet, remove or replace them.**

YES, This indicates an intermittent open loop or +25% inductance change. If you have any splices that are not soldered and sealed with an adhesive heat shrink or epoxy resin, replace the splice with one that is. Tighten all screw terminals in the signal cabinet that the loop circuit uses. Check solder joints in the loop circuit, especially on the harness itself. Disconnect and reconnect any connector used in the loop circuit and check for loose pins and sockets in these connectors.

8.5 Troubleshooting Intermittent Detector Lock Ups

Have you been able to see the channel display while the loop was locked up?

NO, See **Troubleshooting Intermittent Loop Fail Problems** and follow the path for unable to see the channel display while the loop failure was occurring.

YES, Were more than two segments lit in the bargraph on the LCD?

NO, Problems of this type tend to be difficult to isolate due to the many possible causes and the short duration of the symptom (usually less than 30 minutes). If the problem occurs more frequently in the morning or when raining, suspect a short to earth ground in the loop / lead-in circuit. This can usually be verified by testing with a MegOhm meter but not always. Vibration can also be a possible cause. Loop wires may be moving slightly in a conduit due to vibrations from truck traffic. Utility lids in the street near the loop may also be a source of problems. Ensure that lids near a loop are bolted down so that they cannot move. Check that each set of loop wires is twisted together in each pull box and that lengths are not excessive. And also see **Troubleshooting Intermittent Loop Fail Problems** and follow the path for a loop failure that displays **L lo** on the LCD.

YES, See **Troubleshooting Intermittent Loop Fail Problems** and follow the path for a loop failure that displays **L lo** on the LCD.

8.6 Things To Know About Loops

Always use a wire with cross-linked Polyethylene insulation (insulation type XLPE) for loop wire.

Typical sensing height is $\frac{2}{3}$ of the shortest leg of a loop. Therefore, a 6' x 6' loop will have a detection height of 4'.

The inductance of a conventional four-sided loop can be estimated using the formula:

$$L = P \times (T^2 + T) / 4$$

Where: L = Loop Inductance in microhenries
P = Loop Perimeter in feet
T = Number of Turns of Wire

Therefore, a 6' by 6' loop with 3 turns would have an inductance of:

$$L = (6 + 6 + 6 + 6) \times (3^2 + 3) / 4$$

$$L = 24 \times (9 + 3) / 4$$

$$L = 24 \times 12 / 4$$

$$L = 24 \times 3$$

$$L = 72 \text{ microhenries}$$

The inductance of a Quadrupole loop can be estimated using the formula:

$$L = [P \times (T_{OL}^2 + T_{OL}) / 4] + [CL \times (T_{CL}^2 + T_{CL}) / 4]$$

Where: L = Loop Inductance in microhenries
P = Loop Perimeter in feet
T_{OL} = Number of Turns of Wire
(Outer Legs)
CL = Length of Center Leg in feet
T_{CL} = Number of Turns of Wire
(Center Leg)

Therefore, a 6' by 50' Quadrupole loop with a 2-4-2 configuration would have an inductance of:

$$L = [(6 + 50 + 6 + 50) \times (2^2 + 2) / 4] + [50 \times (4^2 + 4) / 4]$$

$$L = [112 \times (4 + 2) / 4] + [50 \times (16 + 4) / 4]$$

$$L = (112 \times 6 / 4) + (50 \times 20 / 4)$$

$$L = (112 \times 1.5) + (50 \times 5)$$

$$L = 168 + 250$$

$$L = 418 \text{ microhenries}$$

Loop Feeder cable typically adds 0.22 microhenries of inductance per foot of cable.

Total inductance of loops connected in series: $L_{TOTAL} = L_1 + L_2 + L_3 + \dots + L_N$

Total inductance of loops connected in parallel: $L_{TOTAL} = 1 / [(1 / L_1) + (1 / L_2) + (1 / L_3) + \dots + (1 / L_N)]$

This page intentionally left blank.