

## SB Sensor Box Mounting Plates

- Fits SB1i & SB2i models
- Sold separately
- Factory installation available upon request

### Description

The stainless steel mounting plates simplify mounting and zero calibration of the SB sensor boxes.

Available in three (3) variations to meet most mounting orientations and space limitations.

### Accessories

Screws and tapped bushings included.

### Part Number

SBBB1: Square 100x100 mm

SBBS1: Rectangle 129x65mm

SBBW1: Right Angle 129x72x38mm

TECHNICAL SPECIFICATIONS			
MATERIAL	Stainless Steel		
WEIGHT (PLATE ONLY)	SBBB1	SBBS1	SBBW1
	128 grams	102 grams	272 grams
HARDWARE WEIGHT	approx. 10 grams		
DIMENSIONS	see dimension drawings		

Figure 1: SBBB1 "Square" Dimensions

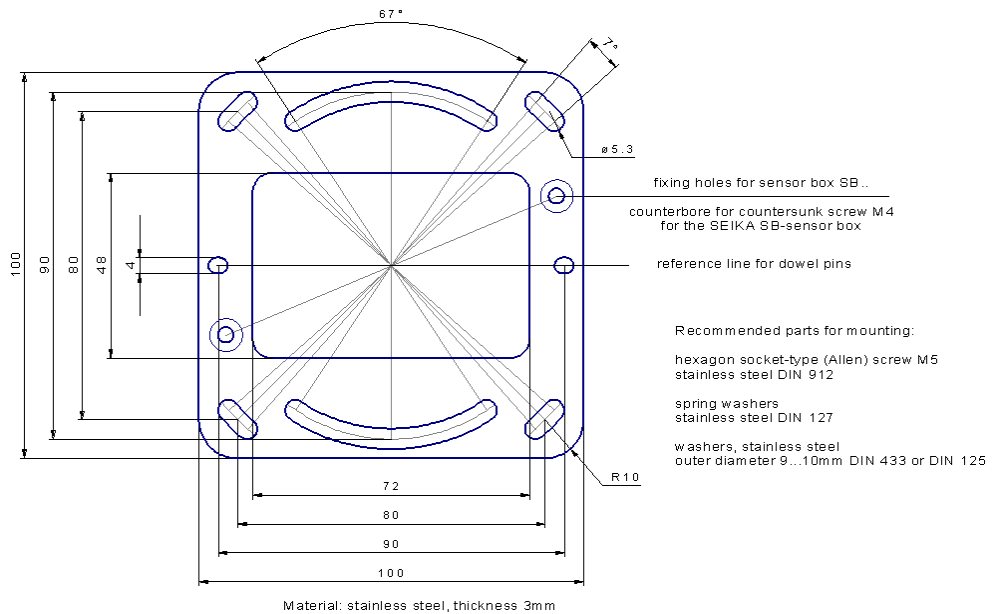

The information and material presented may not be published, broadcast, rewritten, or redistributed without the expressed written consent of Rieker® Inc.  
 The content presented is provided for informational purposes only and subject to change.  
 ©2002-2015 Rieker® Inc. All Rights Reserved.  
 FORM NUMBER SK0057\_1/1/11 UPDATED: 1/29/15

**Figure 2:** SBBS1 "Rectangle" Dimensions

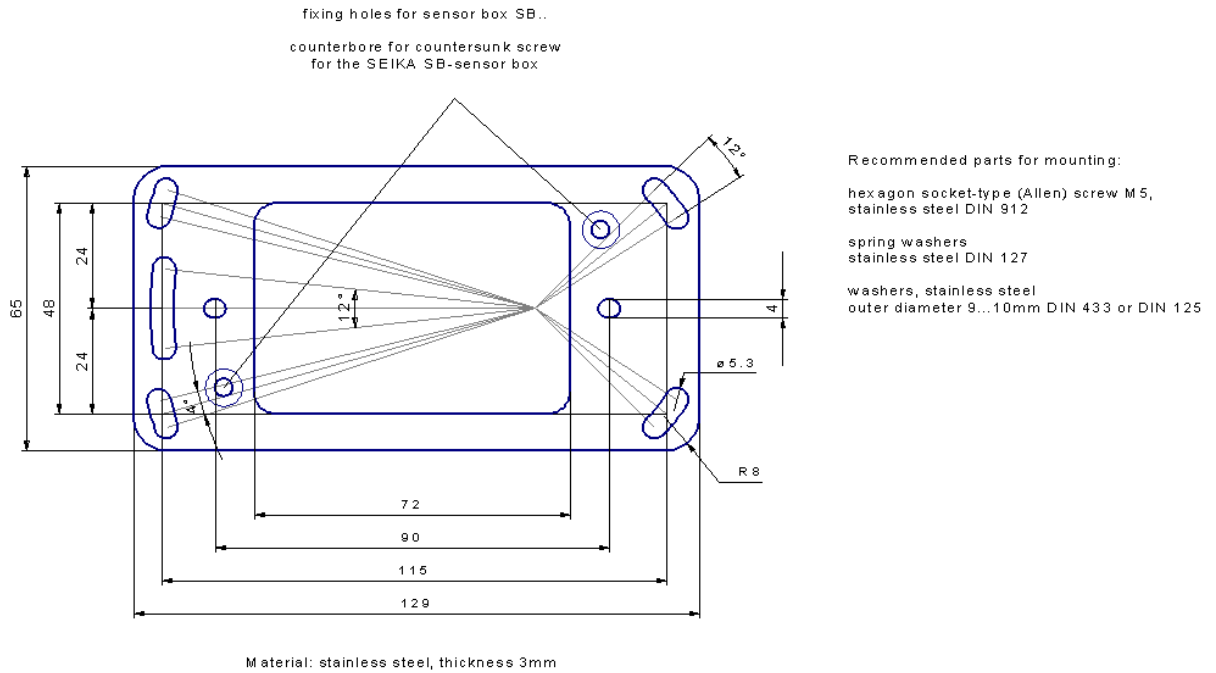

**Figure 3:** SBBW1 "L-Bracket" Dimensions

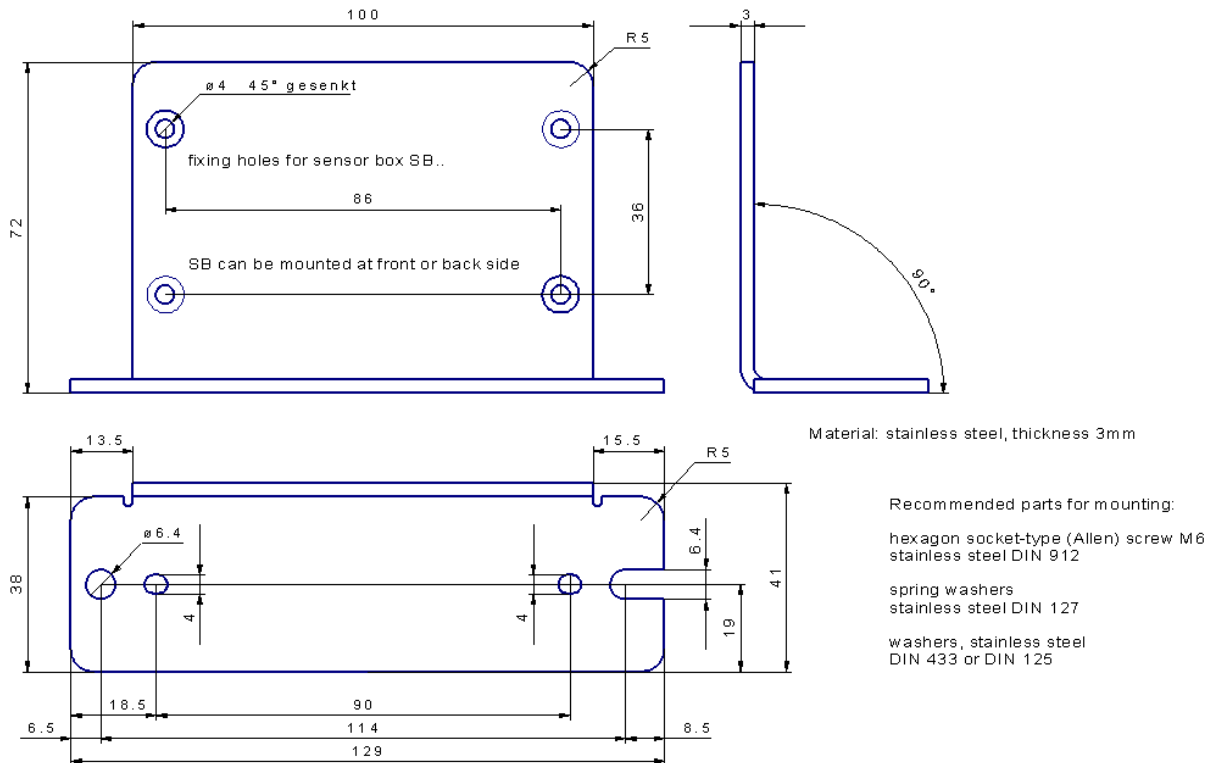

The information and material presented may not be published, broadcast, rewritten, or redistributed without the expressed written consent of Rieker® Inc. ©2002-2015 Rieker® Inc. All Rights Reserved. FORM NUMBER SK0057\_11/11 UPDATED: 1/29/15