

C2-30

Advanced Actuator Controller

concens 
- excellent electric actuators



The C2-30 is designed for driving two Concens actuators in parallel. Synchronization is achieved by adjusting actuator speed during operation.

If adjustment cannot compensate unbalance between actuators, the actuators will be stopped. This way mechanical stress and breakage can be avoided. Additionally the C2-30 includes current limiter and power stage temperature protection. C2-30 has adjustable start and stop ramps for smooth operation.

The basic control is done with Forward-, Backward-, and Stop-commands, either in continuous mode or pulse mode.

Calibration input is for driving the system to its initial position. This is done with low speed.

A wide range of parameters can be altered to suit to different demands and applications.

The parameters are set with the handy interface C2-Prog or laptop pc to the Config- connector.

Features

- Synchronized parallel driving
- Current and temperature protection
- Settable drive speed
- Adjustable start- and stop ramp
- Different control modes
- Wide range of parameters
- Easy setting with serial interface
- Good repeatability of settings
- Autobalance feature

Technical Data

Supply Voltage	12-35VDC/24VDC, filtered less than. 20% ripple
Quiescent current	15mA
Motor current	2x10A cont. 2x20A 25% duty
PWM frequency	2kHz
Current limit	1-20A
Temperature limit	120°C (Power stage)
Ramp times	0-2 sec
Pulse input freq.	max.1kHz
Pulse inputs	pull- up/down 10kΩ (Hi/L0; 4-30V/0-1V)
Control inputs	0-1V=OFF; 4-30V=ON (impedance 10kΩ)
Fault output	Active, pull down max.50mA
Aux. voltage output	5V/20mA
Measures	78 X 73 X 25mm
Operating temp.range	-20 to 60°C
Weight of board	110g
CE	Electromagnetic compatibility Industrial Environment

FIG. 1

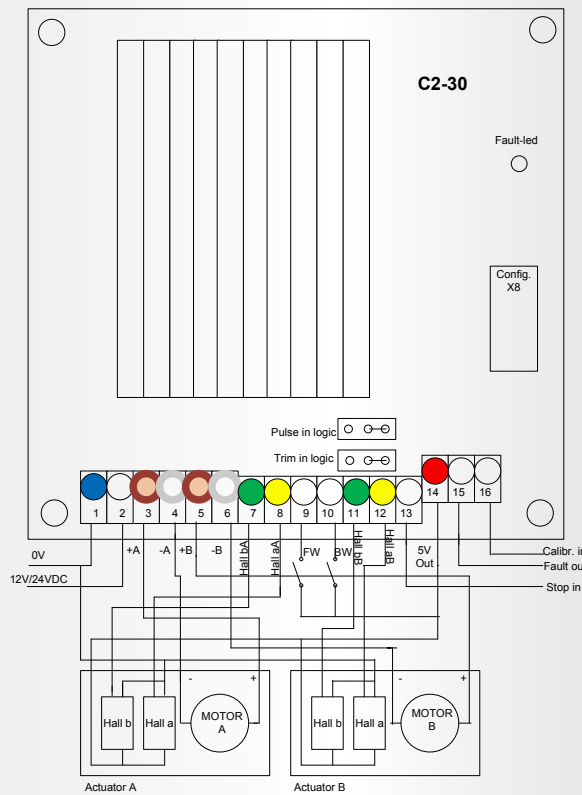

Note: Color combination is example only

FIG. 2

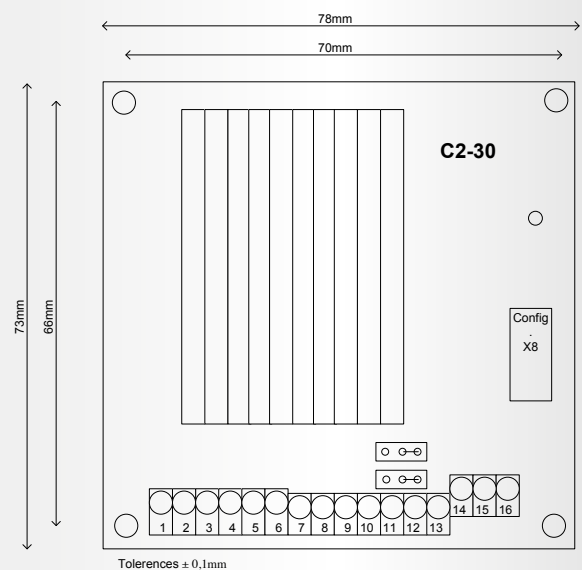

Tolerances ± 0,1mm

Screw Terminals

- 1 **GND (0V) + (blue wire for hall)**
- 2 **Supply 12-35VDC/24V DC (use fuse)**
- 3 **Actuator A +**
- 4 **Actuator A -**
- 5 **Actuator B +**
- 6 **Actuator B -**
- 7 **Hall b motor A (green)**
- 8 **Hall a motor A (yellow)**
- 9 **Forward(out) pos. command only**
- 10 **Backward(in) pos. command only**
- 11 **Hall b motor B (green)**
- 12 **Hall a motor B (yellow)**
- 13 **Stop, input for external stop input**
Pos. command only.
- 14 **5V/20mA output for Hall and controls** e.g. FW/BW command (red wire for hall)
- 15 **Fault output, active low on alarm.**
Open collector.
- 16 **Calibration, pos. command starts** calibration routine.

Connect motors and supply as in picture. Supply voltage 12-35VDC/24VDC must be filtered ripple less than 20%.

Inputs/Outputs

- **Pulse A and B** are for incoming feedback pulse-lines. Parameter 13 must be set to "1".
- **FW & BW** are command inputs forward/backward.
- **STOP** input is for the use of external stop command (eg. end switches).
- **Calibration input** is for starting the calibration routine.
- **FAULT output** - refer to fall situations on page 3
- **INPUTS:** 4V-30V as "high" signal level and 0V-1V as "low" signal level
- **OUTPUT:** NPN open collector max. 50mA

Parameter Discription

- **Running Speed** is the speed which is used in normal mode.
- **Calibration Speed** is the low speed used during calibration-routine.
- **Start- and stop ramps** define the acceleration and deceleration time to 0-100%-0 speed.
- **Current limit** is limit value for current trip. If current value is exceeded the motors will be stopped. During the period of start ramp + 1 sec the current limit is 1,5 times the current limit set value.
- **Difference limit** is the value for largest allowable difference between A an B pulse counters. If value is exceeded motors will be stopped.
- **Adjust behavior** defines how fast and intensively the controller will adjust the synchronization between motors A and B. Smooth 1 → Aggressive 10.
- **I-trip-indication** – fault output can be set to "on"(default) also in current trip situation.
- **Start condition** enables the device to re-start the motor to both or only to opposite direction after a trip or stop situation.
- **Control Mode** sets the control-mode. In continuous mode the motor runs as long as command (fw or bw) is "on". In impulse mode a short command starts the motor and the direction is changed with opposite command. Motor will stop only with "stop" command. In "Impulse-2" mode motor starts with short (fw/bw) impulse. Following command stops the motor, and next command (fw/bw) starts the motor again. In "Continuous(4)" mode actuators run as long as buttons are activated and during calibration buttons must be activated too. Of course, in all modes the difference limit, current limit and stop-command will stop the motors.
- **Safety Reverse** means automatic reverse run if the actuator has been stopped as a result of overload = I-trip. Stop input also triggers this function.
- **Auto-balance trigger** parameter value sets the starting point for auto balance. Value is the number of pulses counted from mechanical home.
- **Double pulse mode** enables the controller to handle actuators with double hall pulses. Must always be enabled when using Concens actuators.
- **End limit fw** is a pulse counter "end stop" for fw direction. The positions is determined in pulse edges from 1-65535. Value 0 means that end stop is not in use. Note: This feature cannot be used in all combinations of gear ratio and stroke length due to number of pulses may exceed 65535.
- **Calibration routine** is a calibration cycle for balancing the system. Calibration can be started by giving fw and bw commands at the same time for 3 sec or with incoming signal to calibration input. Calibration routine can be interrupted with new FW or BW command or signal to STOP input. When calibration routine starts, both motors start to run to same direction and will run until current limit stops the motor or pulses stop coming. During the calibration routine the fault led is blinking slowly. When blinking stops and both motors have stopped the device has reset the pulse counters. Now the devise is ready for use. If there is need to change the calibration direction, swap the motor wires and the hall wires.

- **Auto balance** starts balancing routine before mechanical endstop. The trigger point is set with parameter 12. If "auto balance" is active it balances the system automatically in the end of stroke. This will prevent the possible pulse error accumulation. Auto balance always works to the calibration direction.

Fault Situations

Motor is jammed (current trip), pulses disappear or pulse counter difference is too high (difference limit). The controller will stop the motors and FAULT output will be pulled down (also in I-trip if indication is enabled). When motor is restarted the FAULT output is reset. Faults are also indicated with fault-led as follows:

- 1 blink = position corrupted(calibration needed)
- 2 blinks = current trip
- 3 blinks = pulses disappear
- 4 blinks = difference limit
- 5 blinks = temperature protection

Jumpers

In normal mode both switches SW1/SW2 are set to most right position.(See Fig.1)

Monitoring

During normal use it is possible to monitor the function of controller with the C2-PROG. Select the monitor mode in C2-PROG and you can check the following values:

- 1 current, Motor A 10-250 = 1-25A
- 2 current, Motor B 10-250 = 1-25A
- 3 pulse count/run cycle, only motor A
- 4 pulse count difference
- 5 position counter A 0-65535
- 6 position counter B 0-65535

Feedback Pulses

The controller counts pulse edges so counted value is double compared to the actual number of pulses.

Parameter List

Connect C2-PROG or PC to the Config-connector. This can be done with power on. C2-PROG displays the type of the device. Push the select button and you can scan the parameters with arrow buttons. Parameters are changed with +/- buttons. Store new settings with save button (press and hold for more than 5 sec).

Parameter list with:	Quality	Set range	Default
1 Running speed	40-100%	40-100	100(%)
2 Calibration speed	20-60%	20-60	60(%)
3 Start ramp	0-2sec	0-20	0.5(sec)
4 Stop ramp	0-2sec	0-20	0(sec)
5 Current limit	1-25A	10-250	20(2A)
6 Difference limit	3-50pulses	3-50	10(pulses)
7 Behavior	smo->aggr	1-10	5
8 I-trip indication	disa=0; ena=1		1
9 Start condition	both dir=0; only rev if I-trip=1; only rev if stop=2; only rev=3		1
10 Control mode	cont=1; impuls=2; impuls=3; Cont + cont calibration=4		1
11 Safety reverse time	disa=0; 1-30 reverse time after I-trip		0(sec)
12 Auto balance trigger	disa=0; 1-255 trigger point active		0(pulses)
13 Double pulse mode	disa=0; ena=1		1
14 End limit FW	disa=0; FWD end limit=1-65535		0(pulses)



