

RT9-RD-/R20D1

SMD - DIP 16 Package

- Wide (2:1) input range
- Operating temperature: -40°C ~ +85°C
- 1500VDC isolation
- No heat sink required
- Internal SMD construction
- MTBF>1,000,000 hours
- Short circuit protection(Automatic recovery)
- Industry standard pinout
- RoHS Compliance



RoHS

PRODUCT PROGRAM							
Part Number	Input			Output			Efficiency (% Typ.)
	Voltage (VDC)			Voltage (VDC)	Current (mA)		
	Nominal	Range	Max.*		Max.	Min.	
RT9-1205RD20D1	12	9-18	22	±5	±200	±20	74
RT9-1212RD20D1				±12	±83	±8	78
RT9-1215RD20D1				±15	±67	±7	78
RT9-1203R20D1				3.3	500	50	70
RT9-1205R20D1				5	400	40	74
RT9-1212R20D1				12	167	16	78
RT9-2405RD20D1	24	18-36	40	±5	±200	±20	74
RT9-2412RD20D1				±12	±83	±8	78
RT9-2415RD20D1				±15	±67	±7	78
RT9-2403R20D1				3.3	500	50	72
RT9-2405R20D1				5	400	40	76
RT9-2412R20D1				12	167	16	80

*Input voltage can't exceed this value, or will cause the permanent damage.

APPLICATIONS

The RT9-RD20D1 and RD9-R20D1 Series are specially designed for applications where a wide range input voltage power supplies are isolated from the input power supply in a distributed power supply system on a circuit board.

These products apply to:

- 1) Where the voltage of the input power supply is wide range(voltage range d2:1);
- 2) Where isolation is necessary between input and output (Isolation Voltage d1500VDC);
- 3) Where the regulation of the output voltage and the output ripple noise are demanded.

MODEL SELECTION

RT9-2405RD20D1

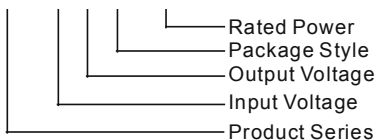

COMMON SPECIFICATIONS						
Item	Test conditions	Min.	Typ.	Max.	Units	
Storage humidity range				95	%	
Operating temperature		-40		85	°C	
Storage temperature		-55		125		
Temp. rise at full load			15			
Lead temperature	1.5mm from case for 10 seconds			300		
Short circuit protection		Continuous, automatic recovery				
Cooling		Free air convection				
Package material		Epoxy Resin (UL94-V0)				
MTBF		1000			K hours	
Weight			5.2		g	
Reflow Soldering Temperature		Peak temp. ≤240°C, maximum duration time ≤60s at 217°C. For actual application, please refer to IPC/JEDEC J-STD-020D.1.				

STAND Juni 2016 Rev.01

RT9-RD-/R20D1

TYPICAL TEMPERATUR CURVE

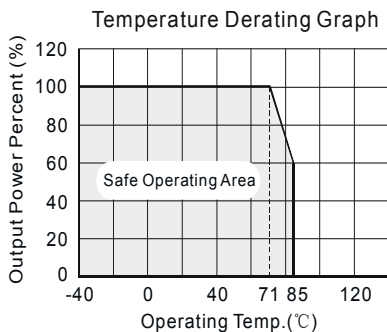

APPLICATION NOTE

Requirement On Output Load

In order to ensure the product operate efficiently and reliably, in addition to a max load (namely full load), a minimum load is specified for this kind of DC/DC converter. Make sure the specified range of input voltage is not exceeded, the minimum output load **no less than 10% load**. If the actual load is less than the specified minimum load, the output ripple may increase sharply while its efficiency and reliability will reduce greatly. If the actual output power is very small, please add an appropriate resistor as extra loading, or contact our company for other lower output power products.

Recommended Circuit

All the WRA_LT-2W & WRB_LT-2W Series have been tested according to the following recommended testing circuit before leaving factory. This series should be tested under load. (See Figure 1).

If you want to further decrease the input/output ripple, you can increase capacitance properly or choose capacitors with low ESR. However, the capacitance of the output filter capacitor must be proper. If the capacitance is too big, a startup problem might arise. For every channel of output, provided the safe and reliable operation is ensured, the greatest capacitance of its filter capacitor sees (Table 1).

General: Cin: 12V 100µF
24V 10µF~47µF
Cout: 10µF/100mA

Input Current

When it is used in unregulated power supply, be sure that the fluctuating range of the power supply and the rippled voltage do not exceed the module standard. Input current of power supply should afford the flash startup average current of this kind of DC/DC module (Figure 2).

General: Vin:12V Iave =432mA
Vin:24V Iave =216mA

No parallel connection or plug and play

ISOLATION SPECIFICATIONS

Item	Test conditions	Min.	Typ.	Max.	Units
Isolation voltage	Tested for 1 minute and 1mA max.	1500			VDC
Isolation resistance	Test at 500VDC	1000			MΩ
Isolation Capacitance	Input/Output		85		pF

OUTPUT SPECIFICATIONS

Item	Test conditions	Min.	Typ.	Max.	Units
Output power	See above products program	0.2		2	W
Positive voltage accuracy	Refer to recommended circuit		±1	±3	%
Negative voltage accuracy	Refer to recommended circuit		±3	±5	
Load regulation	From 10% to 100% load		±0.5	±1*	
Line regulation	Input voltage from low to high		±0.2	±0.5	% / °C
Temperature Drift (Vout)	Refer to recommended circuit			±0.03	
Output ripple & noise**	20MHz Bandwidth		35	150	mVp-p
Switching frequency	100% load, nominal input voltage		300		KHz

*Dual output models unbalanced load: ±5%.

**Test ripple and noise by "parallel cable" method. See detailed operation instructions at Testing of Power Converter section, application notes.

RECOMMENDED CIRCUIT

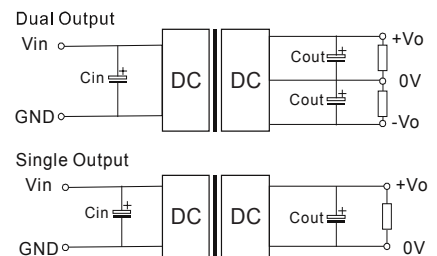

(Figure 1)

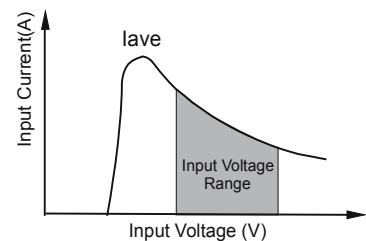

(Figure 2)

Output External Capacitor Table (Table 1)

Single Vout (VDC)	Cout (µF)	Dual Vout (VDC)	Cout (µF)
3.3	2200	±5	680
5	1000	±9	470
9	680	±12	330
12	470	±15	220
15	330	-	-

RT9-RD-/R20D1

OUTLINE DIMENSIONS & PIN CONNECTIONS

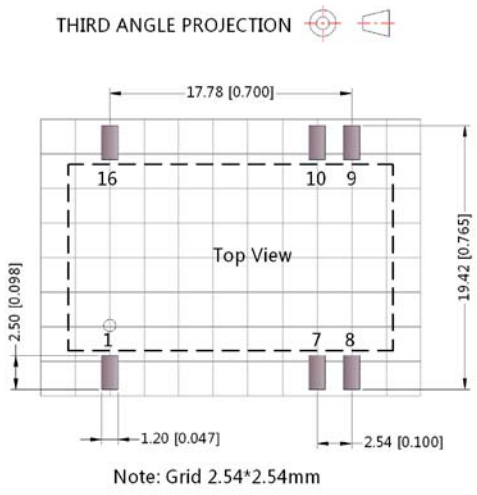
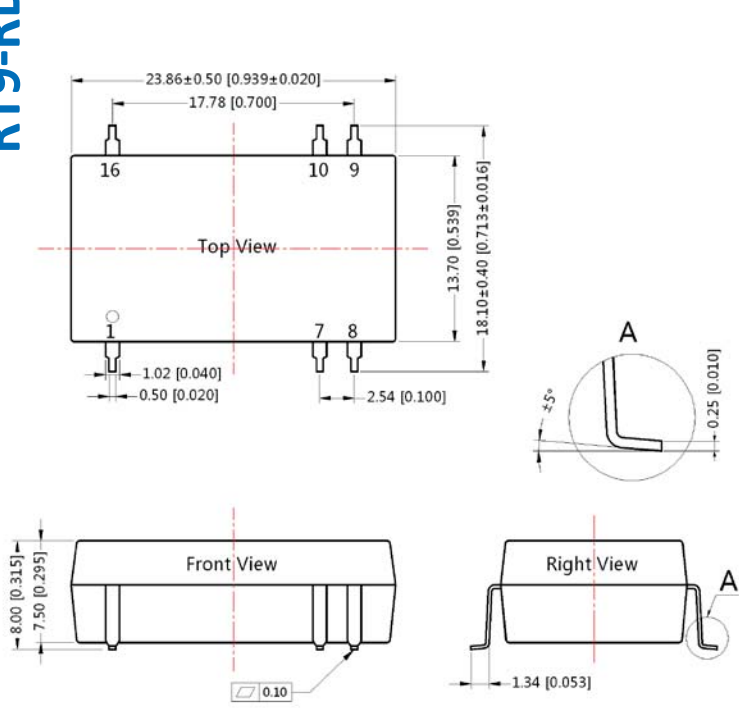

Note:
Unit: mm[inch]
Pin section tolerances: ±0.10[±0.004]
General tolerances: ±0.25[±0.010]

Pin-Out		
Pin	P/RT9-R20D1	P/RT9-RD20D1
1	GND	GND
7	NC	NC
8	NC	0V
9	+Vo	+Vo
10	0V	-Vo
16	Vin	Vin

NC: No Connection

Recommend to use module with more than 10% load, if not, the ripple of the product may exceeds the specification, but does not affect the reliability of the product;

Operation under 10% load will not damage the converter; However, they may not meet all specification listed.
Capacitor MAX load tested at input voltage range and full load.
All specifications measured at Ta=25°C, humidity<75%, nominal input voltage and rated output load unless otherwise specified.
In this datasheet, all the test methods of indications are based on corporate standards.
Only typical models listed, other models may be different, please contact our technical person for more details.

The models listed here are just standard type. If you need a product with special specification or you have questions regarding packing standards (Tube oder Tape/Reel) as well as application support, please contact our specialists: sales@rsg-electronic.de or +49 69-984047-41/-28