

APWR104HR Filtered Avionics Power Supply Module

User's Manual

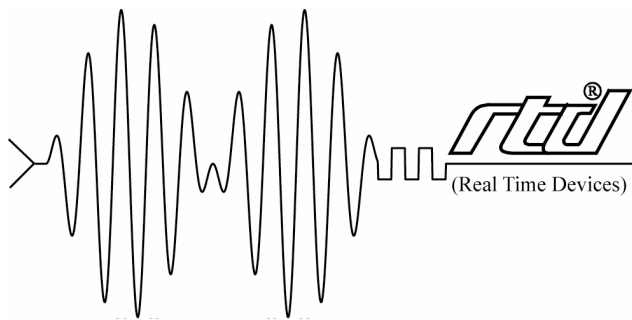

RTD Embedded Technologies, Inc.

"Accessing the Analog World"®

BDM-610020010
Rev B

ISO9001 and AS9100 Certified

APWR104
Filtered Avionics Power Supply Module
User's Manual



RTD Embedded Technologies, Inc.
103 Innovation Blvd.
State College, PA 16804-0906 USA

Phone: (814) 234-8087
FAX: (814) 234-5218

E-Mail
sales@rtd.com
techsupport@rtd.com

Website
www.rtd.com

Revision History

Rev A 03 November 2003 -- Initial release.

Rev B 02/20/2009 added explanation of X1 and X2 jumpers. Also corrected typo in description of TB5

Published by:

RTD Embedded Technologies, Inc.
103 Innovation Blvd.
State College, PA 16804-0906

Copyright 2003 by RTD Embedded Technologies, Inc.
All rights reserved
Printed in U.S.A.

The RTD Logo is a registered trademark of RTD Embedded Technologies. cpuModule and utilityModule are trademarks of RTD Embedded Technologies. PhoenixPICO and PheonixPICO BIOS are trademarks of Phoenix Technologies Ltd. PS/2, PC/XT, PC/AT and IBM are trademarks of International Business Machines Inc. MS-DOS, Windows, Windows 95, Windows 98 and Windows NT are trademarks of Microsoft Corp. PC/104 is a registered trademark of PC/104 Consortium. All other trademarks appearing in this document are the property of their respective owners.

Table of Contents

CHAPTER 1 INTRODUCTION	2
APWR104 Filtered Avionics Power Module.....	2
Features	2
Connectors	3
General Specifications	3
CHAPTER 2 INSTALLING THE UTILITYMODULE	4
Recommended Procedure	4
CHAPTER 3 CONNECTING THE UTILITYMODULE	6
Finding Pin 1 of Connectors	6
PC/104 Bus Connectors, CN1 and CN2	7
Inhibit Input, CN3	8
+16 – 50 VDC Input, TB1	8
Filtered Vout Output, TB2	9
+5 VDC Output, TB3	9
+12 VDC Output, TB4	9
-12 VDC Output, TB5	10
X1 and X2 jumpers	10
CHAPTER 4 USING THE UTILITYMODULE	11
CHAPTER 5 RETURN POLICY AND WARRANTY	12
Return Policy	12
Limited Warranty.....	13

Chapter 1 INTRODUCTION

This manual gives information on the APWR104 Filtered Avionics Power Module. This power supply provides filtered input power, +5 VDC, and optionally +/-12 VDC to power the PC/104 bus and external devices.

APWR104 Filtered Avionics Power Module

The APWR104 Filtered Avionics Power Module was designed to power a PC/104 system from the typical unregulated, noisy 28 VDC aircraft power.

Features

The following are major features of the APWR104 powerModule.

Input:

- 16 – 50 VDC

Outputs:

- +5 VDC @ 6 Amps
- 112 Watts (-50W version) or 140 Watts (-30W version) filtered input voltage
- +/- 12 VDC at 1.17 Amps each, total max power 20 Watts (-50W version only)

HighRel:

- Meets MIL-STD-704A, B, C, and D surge limits
- Designed to meet MIL-STD-461C CE03 and MIL-STD-461D CE102 and DEF STAN 59-41 and 61-5 EMC requirements
- Protects against conducted susceptibility specified in MIL-STD-461C, CS01 and CS02 and against voltage spikes specified in MIL-STD-461C CS06
- Withstands input transient voltages of 80 volts for 1 second per MIL-STD-704A
- -40 to +85 degrees C operation

Connectors

Connectors provided are:

- CN1 and CN2, PC/104 bus
- TB1, 16 – 50 VDC input
- TB2, Filtered input voltage (112 watts for –50W version and 140 watt for –30W version)
- TB3, +5 VDC output @ 6 Amps (30W max)
- TB4, +12 VDC output @ 1.17 Amps (-50W version only)
- TB5, -12 VDC output @ 1.17 Amps (-50W version only)

Note: +12V and -12V supplies combined can not exceed 20 W max

General Specifications

- Dimensions: 3.8 x 4.75 x 0.6" (97 x 120 x 16 mm) including connectors
- Weight (mass):
 - -50W version, 0.42 lb, (0.19 Kg)
 - -30W version, ????
- 4-layer PCB, combined through-hole and surface-mount
- Operating conditions:
- Temperature:
 - -40 to +85 degrees C, operational
- Relative humidity: 0 - 95%, non-condensing
- Storage temperature: -65 to +150 degrees C

Chapter 2 **INSTALLING THE UTILITYMODULE**

Since the utilityModule uses a PC/104 stackthrough bus, the only hardware installation you will do is placing the module to the PC/104 stack. To do this, you will connect the PC/104 bus connector with the matching connector of another module.

Recommended Procedure

We recommend you follow the procedure below to ensure that stacking of the modules does not damage connectors or electronics.

- Turn off power to the PC/104 system or stack.
- Select and install standoffs to properly position the utilityModule on the PC/104 stack.
- Touch a grounded metal part of the stack to discharge any buildup of static electricity.
- Remove the utilityModule from its anti-static bag.
- Check that keying pins in the PC/104 bus connector are properly positioned.
- Check the stacking order: make sure an XT bus card will not be placed between two AT bus cards, or it will interrupt the AT bus signals.
- Hold the utilityModule by its edges and orient it so the bus connector pins line up with the matching connector on the stack.
- Gently and evenly press the utilityModule onto the PC/104 stack.

CAUTION: Do not force the module onto the stack! Wiggling the module or applying too much force may damage it. If the module does not readily press into place, remove it, check for bent pins or out-of-place keying pins, and try again.

Chapter 3 CONNECTING THE UTILITYMODULE

The following sections describe connectors of the utilityModule.

Finding Pin 1 of Connectors

Pin 1 of connectors is indicated by a square solder pad visible on the bottom of the PC board.

Component Locations

The figure below shows locations of major components, including connectors.

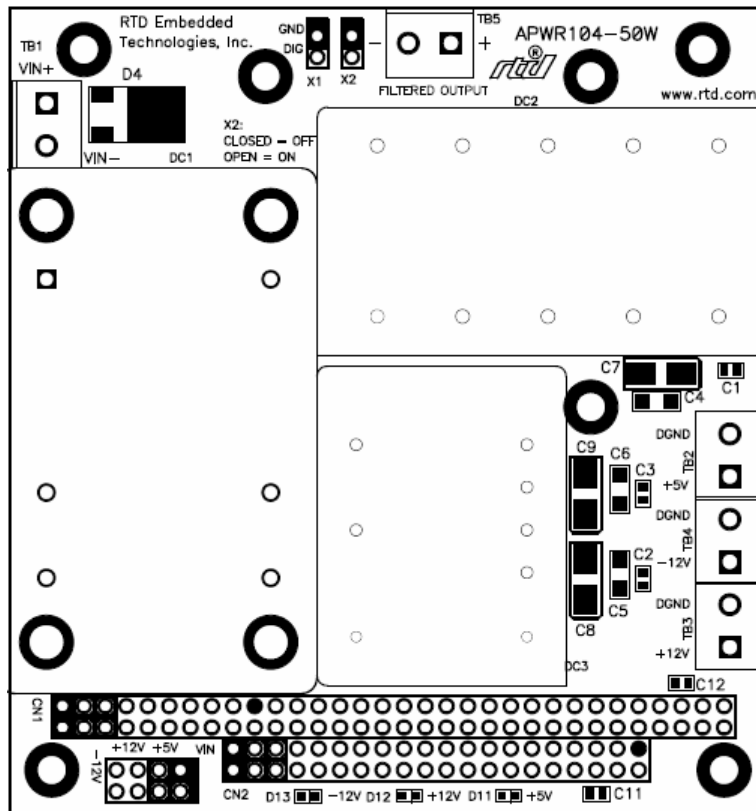

Connector	Function	Dimension
CN1	XT PC/104 bus	64 pin
CN2	AT PC/104 bus	32 pin
CN3	Inhibit Input	2 pin
TB1	16-50 VDC Input	2 terminal
TB2	Filtered Vout Output	2 terminal
TB3	+5 VDC Output	2 terminal
TB4	+12 VDC Output	2 terminal
TB5	-12 VDC Output	2 terminal
X1	Digital ON/OFF*	2 pin
X2	Switch ON*/OFF	2 pin

PC/104 Bus Connectors, CN1 and CN2

Connectors CN1 and CN2 provide PC/104 bus connections. CN1 carries XT bus signals, and CN2 carries additional signals for the AT bus. The signals on CN1 and CN2 conform to the IEEE P966 standard for the PC/104 bus. The APWR104 series power only supplies the +5V, 0V (Gnd), +12V and -12V pins. All other pins are not connected.

The following tables list the connector pinouts:

PC/104 XT Bus Connector, CN1		
Pin	Row A	Row B
1	IOCHCHK*	0V
2	SD7	RESETDRV
3	SD6	+5V
4	SD5	IRQ9
5	SD4	-5V
6	SD3	DRQ2
7	SD2	-12V
8	SD1	ENDXFR*
9	SD0	+12V
10	IOCHRDY	(KEYING PIN)
11	AEN	SMEMW*
12	SA19	SMEMR*
13	SA18	IOW*
14	SA17	IOR*
15	SA16	DACK3
16	SA15	DRQ3
17	SA14	DACK1*
18	SA13	DRQ1
19	SA12	REFRESH
20	SA11	SYSCLK
21	SA10	IRQ7
22	SA9	IRQ6
23	SA8	IRQ5
24	SA7	IRQ4
25	SA6	IRQ3
26	SA5	DACK2*
27	SA4	TC
28	SA3	BALE
29	SA2	+5V
30	SA1	OSC
31	SA0	0V
32	0V	0V

PC/104 AT Bus Connector, CN2		
Pin	Row C	Row D
0	0V	0V
1	SBHE*	MEMCS16*
2	LA23	IOCS16*
3	LA22	IRQ10
4	LA21	IRQ11
5	LA20	IRQ12
6	LA19	IRQ15
7	LA18	IRQ14
8	LA17	DACK0*
9	MEMR*	DRQ0
10	MEMW*	DACK5*
11	SD8	DRQ5
12	SD9	DACK6*
13	SD10	DRQ6
14	SD11	DACK7*
15	SD12	DRQ7
16	SD13	+5V
17	SD14	MASTER*
18	SD15	0V
19	(KEYING PIN)	0V

Note: Two locations on the bus have mechanical keying pins to help prevent misconnection of the PC/104 bus. These keying pins are a part of the PC/104 standard, and we strongly recommend you leave them in place.

If you have other modules without keying pins, we suggest you modify them to include keying.

Inhibit Input, CN3

Connector CN3 is the inhibit input connection for the APWR104. Tying this input to ground will shutdown the power supply.

Pin	Signal	Function	in/out
1	Inhibit	Short to ground shuts down the power supply	in
2	Ground	Ground	

+16 – 50 VDC Input, TB1

Terminal block TB1 is the input power connection for the APWR104. The input range is 16 - 50 VDC. Fully loaded this input can require 10 amps, therefore 18 gauge wire is recommended.

Pin	Signal	Function	in/out
1	Vin +	+16 – 50 VDC input	in
2	Vin -	Ground input	in

Filtered Vout Output, TB2

Terminal block TB2 is the output of the filter. This is 112 watts on the APWR104HR-50W and 140 watts on the APWR104HR-30W of a filtered version of the input power.

Pin	Signal	Function	in/out
1	Vout+	Filtered Vout	out
2	Ground	Ground	out

+5 VDC Output, TB3

The +5 VDC output is supplied to the +5 V pins on the PC/104 bus and to terminal block TB3. This supply is capable of providing 6 amps total that is shared by the PC/104 bus devices and any devices connected to TB3.

Pin	Signal	Function	in/out
1	+5 VDC	Regulated +5 VDC Output	out
2	Ground	Ground	out

+12 VDC Output, TB4

The +12 VDC output of the APWR104HR-50W (not provided on the APWR104HR-30W) is supplied to the +12 V pins on the PC/104 bus and to terminal block TB4. This supply is capable of providing 1.17 amps total that is shared by the PC/104 bus devices and any devices connected to TB4. Note that the total power drawn from the +12 VDC and the -12 VDC supplies together cannot exceed 20 watts.

Pin	Signal	Function	in/out
1	+12 VDC	Regulated +12 VDC Output	out
2	Ground	Ground	out

-12 VDC Output, TB5

The -12 VDC output of the APWR104HR-50W (not provided on the APWR104HR-30W) is supplied to the -12 V pins on the PC/104 bus and to terminal block TB5. This supply is capable of providing 1.17 amps total that is shared by the PC/104 bus devices and any devices connected to TB4. Note that the total power drawn from the +12 VDC and the -12 VDC supplies together cannot exceed 20 watts.

Pin	Signal	Function	in/out
1	-12 VDC	Regulated -12 VDC Output	Out
2	Ground	Ground	Out

X1 and X2 jumpers

Pin	Signal	Function
X1-1	Input Return	Return current
X1-2	Transistor input	5V = Supply OFF 0V = Supply ON
X2-1	Inhibit	Short = Supply OFF Open = Supply ON
X2-2	Input Return	Return current

Chapter 4 USING THE UTILITYMODULE

Using the utilityModule is straightforward. Connect the input to TB1 using good wiring practices keeping the wires as short and as heavy as possible. The +5 VDC is provided. Below is the block diagram:

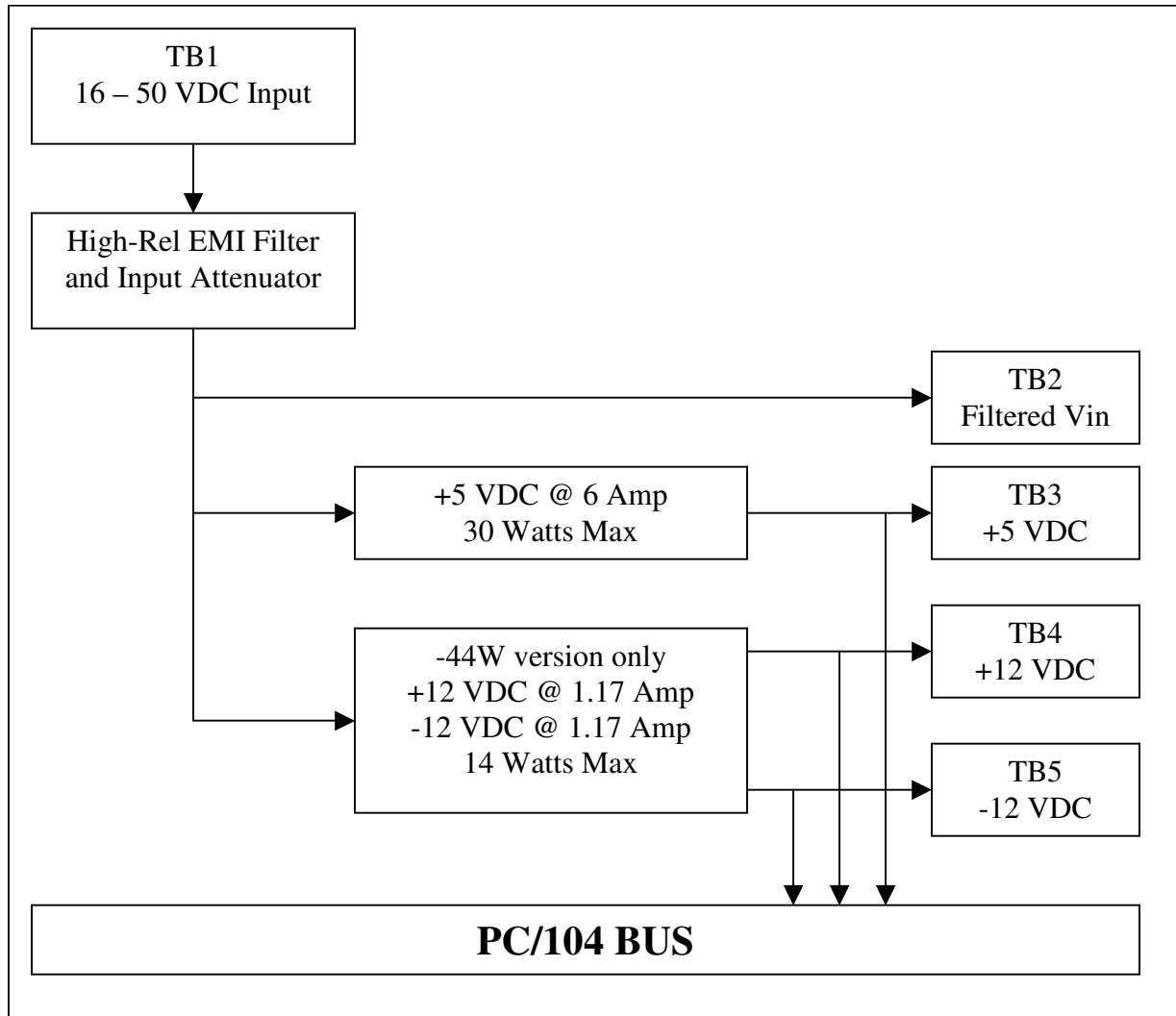

Chapter 5 RETURN POLICY AND WARRANTY

Return Policy

If the utilityModule requires repair, you may return it to us by following the procedure listed below:

Caution: Failure to follow this return procedure will *almost always* delay repair! Please help us expedite your repair by following this procedure.

- 1) Read the limited warranty which follows.
- 2) Contact the factory and request a Returned Merchandise Authorization (RMA) number.
- 3) On a sheet of paper, write the name, phone number, and fax number of a technically-competent person who can answer questions about the problem.
- 4) On the paper, write a detailed description of the problem with the product. Answer the following questions:
 - Did the product ever work in your application?
 - What other devices were connected to the product?
 - How was power supplied to the product?
 - What features did and did not work?
 - What was being done when the product failed?
 - What were environmental conditions when the product failed?
- 5) Indicate the method we should use to ship the product back to you.
 - We will return warranty repairs by UPS Ground at our expense.
 - Warranty repairs may be returned by a faster service at your expense.
 - Non-warranty repairs will be returned by UPS Ground or the method you select, and will be billed to you.
- 6) Clearly specify the address to which we should return the product when repaired.
- 7) Enclose the paper with the product being returned.
- 8) Carefully package the product to be returned *using anti-static packaging!* We will not be responsible for products damaged in transit for repair.
- 7) Write the RMA number on the outside of the package.
- 8) Ship the package to:

RTD Embedded Technologies, Inc.
103 Innovation Blvd.
State College PA 16804-0906
USA

Limited Warranty

RTD EMBEDDED TECHNOLOGIES, INC. WARRANTS THE HARDWARE AND SOFTWARE PRODUCTS IT MANUFACTURES AND PRODUCES TO BE FREE FROM DEFECTS IN MATERIALS AND WORKMANSHIP FOR ONE YEAR FOLLOWING THE DATE OF SHIPMENT FROM RTD EMBEDDED TECHNOLOGIES. THIS WARRANTY IS LIMITED TO THE ORIGINAL PURCHASER OF PRODUCT AND IS NOT TRANSFERABLE.

DURING THE ONE-YEAR WARRANTY PERIOD, RTD EMBEDDED TECHNOLOGIES WILL REPAIR OR REPLACE, AT ITS OPTION, ANY DEFECTIVE PRODUCTS OR PARTS AT NO ADDITIONAL CHARGE, PROVIDED THAT THE PRODUCT IS RETURNED, SHIPPING PREPAID, TO RTD EMBEDDED TECHNOLOGIES. ALL REPLACED PARTS AND PRODUCTS BECOME THE PROPERTY OF RTD EMBEDDED TECHNOLOGIES. BEFORE RETURNING ANY PRODUCT FOR REPAIR, CUSTOMERS ARE REQUIRED TO CONTACT THE FACTORY FOR AN RMA NUMBER.

THIS LIMITED WARRANTY DOES NOT EXTEND TO ANY PRODUCTS WHICH HAVE BEEN DAMAGED AS A RESULT OF ACCIDENT, MISUSE, ABUSE (SUCH AS: USE OF INCORRECT INPUT VOLTAGES, IMPROPER OR INSUFFICIENT VENTILATION, FAILURE TO FOLLOW THE OPERATING INSTRUCTIONS THAT ARE PROVIDED BY RTD EMBEDDED TECHNOLOGIES, "ACTS OF GOD" OR OTHER CONTINGENCIES BEYOND THE CONTROL OF RTD EMBEDDED TECHNOLOGIES), OR AS A RESULT OF SERVICE OR MODIFICATION BY ANYONE OTHER THAN RTD EMBEDDED TECHNOLOGIES. EXCEPT AS EXPRESSLY SET FORTH ABOVE, NO OTHER WARRANTIES ARE EXPRESSED OR IMPLIED, INCLUDING, BUT NOT LIMITED TO, ANY IMPLIED WARRANTIES OF MERCHANTABILITY AND FITNESS FOR A PARTICULAR PURPOSE, AND RTD EMBEDDED TECHNOLOGIES EXPRESSLY DISCLAIMS ALL WARRANTIES NOT STATED HEREIN. ALL IMPLIED WARRANTIES, INCLUDING IMPLIED WARRANTIES FOR MERCHANTABILITY AND FITNESS FOR A PARTICULAR PURPOSE, ARE LIMITED TO THE DURATION OF THIS WARRANTY. IN THE EVENT THE PRODUCT IS NOT FREE FROM DEFECTS AS WARRANTED ABOVE, THE PURCHASER'S SOLE REMEDY SHALL BE REPAIR OR REPLACEMENT AS PROVIDED ABOVE. UNDER NO CIRCUMSTANCES WILL RTD EMBEDDED TECHNOLOGIES BE LIABLE TO THE PURCHASER OR ANY USER FOR ANY DAMAGES, INCLUDING ANY INCIDENTAL OR CONSEQUENTIAL DAMAGES, EXPENSES, LOST PROFITS, LOST SAVINGS, OR OTHER DAMAGES ARISING OUT OF THE USE OR INABILITY TO USE THE PRODUCT.

SOME STATES DO NOT ALLOW THE EXCLUSION OR LIMITATION OF INCIDENTAL OR CONSEQUENTIAL DAMAGES FOR CONSUMER PRODUCTS, AND SOME STATES DO NOT ALLOW LIMITATIONS ON HOW LONG AN IMPLIED WARRANTY LASTS, SO THE ABOVE LIMITATIONS OR EXCLUSIONS MAY NOT APPLY TO YOU.

THIS WARRANTY GIVES YOU SPECIFIC LEGAL RIGHTS, AND YOU MAY ALSO HAVE OTHER RIGHTS WHICH VARY FROM STATE TO STATE.