



1225 Isley Road, Gastonia, NC
28052
Phone: [800-634-7704](tel:800-634-7704) Fax:
800-253-6634
www.rwmcasters.com

75 Series Kingpinless™ Casters

Heavy Duty Kingpinless™ Casters



RWM Casters 75 Series industrial casters feature the patented Kingpinless™ caster design. The 75 Series is recommended for the most demanding heavy duty industrial caster applications and is available with up to 3" wheels for higher capacity applications. All swivel sections are supplied with a lubrication fitting for field maintenance. The 75 series is case hardened to provide an extended service life. It will not crack like through hardened or induction hardened construction provided by other caster manufacturers.

Our 75 series industrial casters are proudly made in the USA! Log in below to download free 2D or 3D CAD drawings and models of this caster. If our standard product line doesn't meet your specifications, give us a call. Custom design and production of custom casters for application specific standards is our specialty!



75-UIR-0625-S



75-UIR-0625-R



75-MUB-0830-S-60D-FICWB

Top Plates

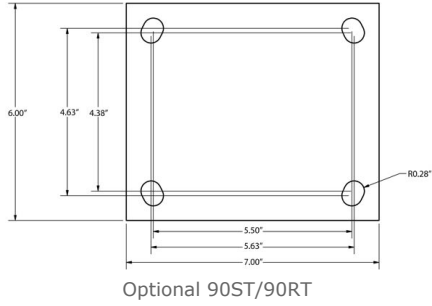
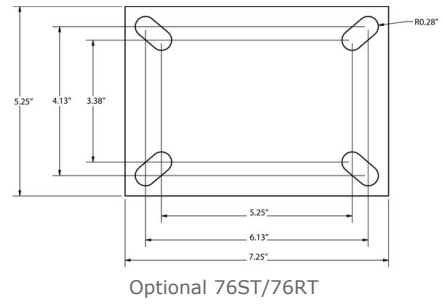
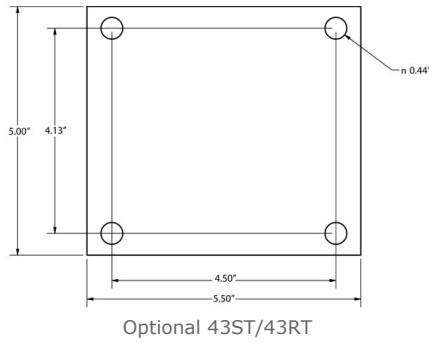
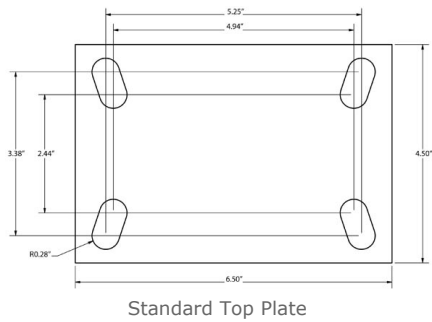

Swivel Sections and Cross Sections

KINGPINLESS™ CASTER SWIVEL SECTION

Raceway Diameter

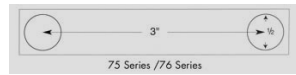
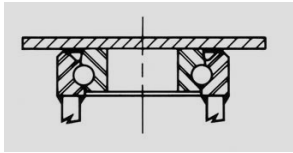

Features

Raceway Design: Patented Kingpinless™ single ball bearing precision machined raceway hardened to 53 Rockwell C minimum. Swivel section features 3" diameter raceway with 1/2" ball bearings. The notched raceway is standard.

Capacity: 6,000 lbs.

Leg Thickness: 5/16" formed steel

Axle: 3/4" bolt with lock or slotted nut as required

Finish: Laguna Blue powder coat

Wheels: Wheels are available with either a 1" roller bearing which rotates on a hardened and ground spanner bushing or 3/4" tapered bearings that rotate on the axle. All wheels are equipped with a lubrication fitting.

Mounting Plate Size: 4-1/2" x 6-1/2" x 5/16"

Bolt Hole Spacing: 2-7/16" x 4--15/16", slotted to 3-3/8" x 5-1/4"

Mounting Bolt Diameter: 1/2"

Applications

The 75 Series typical applications include dollies, utility carts, tow line and platform trucks. It is also ideal for: tow lines, shock load applications and abusive conditions, production line dollies & trucks used in various industries including but not limited to: boat & ship molding and building, automotive, aerospace, metal fabricating, metal forging, heavy machinery and equipment, military equipment, mobile homes, etc. tractor pulled trailers, extreme duty platform trucks and material handling carts, air cargo and ground support equipment, storage tanks, gantries and heavy duty processing equipment, coliseum and gymnasium equipment, shipping/receiving carts, warehousing and freight terminal dollies and carts, heavy duty power towed application seen in tire manufacturing and countless other heavy duty applications.

Options

CWB: Cam Wheel Brake
DSL: Demountable Swivel Lock
HT: High Temperature Lubrication
LT: Low Temperature Lubrication
PCWB: Poly Cam Wheel Brake
SL: Swivel Lock
SR: Sealed Swivel Raceway
ZP: Zinc Plated
FICWB: Field Installable Cam Wheel Brake (FICWB Brake is for swivel casters only)
HTP: High Temperature Paint
FG: Foot Guard
LSL: L-Type Swivel Lock
VSL: Vertical Swivel Lock
SWP: Sweeper Brush

Benefits of Kingpinless™ Raceway

Our patented offset precision-machined raceway exerts radial force evenly where there is full contact between the ball bearing and the raceway. RWM's unique design adds more mass at key points. This, plus more thorough heat treatment, provides additional strength and combats brinelling into the core material.

The Result:

- No direct "hammering" forces on the intersections of the raceways
- Vastly reduced raceway wear
- Elimination of the "pull apart" forces of stress in the swivel section
- Smoother swiveling action
- High maneuverability
- Longer service life
- Less maintenance
- Extra impact resistance
- High radial force absorption

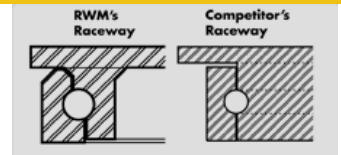

Optional Mounting Plates

Optional Top Plate Number	Mounting Plate	Bolt Hole Spacing	Bolt Size
90ST***	6" x 7"	4-5/8" x 5-1/2" slotted to 4-3/8" x 5-5/8"	1/2"
90RT	6" x 7"	4-5/8" x 5-1/2" slotted to 4-3/8" x 5-5/8"	1/2"
43ST	5" x 5-1/2"	4-1/8" x 4-1/2"	3/8"
43RT	5" x 5-1/2"	4-1/8" x 4-1/2"	3/8"
76ST**	5-1/4" x 7-1/4"	3-3/8" x 5-1/4", slotted to 4-1/8" x 6-1/8"	1/2"
76RT	5-1/4" x 7-1/4"	3-3/8" x 5-1/4", slotted to 4-1/8" x 6-1/8"	1/2"

* Subtract 1/16" OAH when using this top plate

** Add 1/16" OAH when using this top plate

*** Add 3/16" OAH when using this top plate

Specifications

Wheel Diameter	Wheel Width	Wheel Type	lbs. Capacity	Overall Height	Straight Roller Bearing	Ball Bearing	Tapered Roller Bearing	Swivel Load	Approx Weight
5"	2-1/2"	Cast Iron	2000	6-1/2"	75-CIR-0525-S		75-CIT-0525-S	1-1/8"	18.0
6"	2-1/2"	Cast Iron	1800	7-1/2"	75-CIR-0625-S		75-CIT-0625-S	1-5/16"	17.0
6"	2-1/2"	Durastan	1600	7-1/2"	75-DUR-0625-S			1-5/16"	11.5
6"	2-1/2"	Forged Steel	5000	7-1/2"	75-FSR-0625-S		75-FST-0625-S	1-5/16"	20.5

6"	2-1/2"	GT	2300	7-1/2"		75- GTB -0625-S		1-5/16"	11.5
6"	2-1/2"	Rubber on Iron	540	7-1/2"	75- RIR -0625-S			1-5/16"	16.5
6"	2-1/2"	Urethane on Iron	1620	7-1/2"	75- UIR -0625-S		75- UIT -0625-S	1-5/16"	16.5
6"	2-1/2"	V-Groove Iron	2500	7-1/2"	75- VIR -0625-S		75- VIT -0625-S	1-5/16"	16.5
6"	2-1/2"	Rubber on Iron-EHT	810	7-1/2"	75- RIR -0625-S-EHT		75- RIT -0625-S-EHT	1-5/16"	16.5
6"	3"	Cast Iron	3000	7-1/2"	75- CIR -0630-S		75- CIT -0630-S	1-5/16"	18.5
6"	3"	Durastan	2000	7-1/2"	75- DUR -0630-S			1-5/16"	12.5
6"	3"	Forged Steel	6000	7-1/2"	75- FSR -0630-S		75- FST -0630-S	1-5/16"	31.0
6"	3"	Nylatron HD	6000	7-1/2"		75- NYB -0630-S		1-5/16"	12.5
6"	3"	Rubber on Iron-EHT	1080	7-1/2"	75- RIR -0630-S-EHT		75- RIT -0630-S-EHT	1-5/16"	17.5
6"	3"	Urethane on Iron	2000	7-1/2"	75- UIR -0630-S		75- UIT -0630-S	1-5/16"	17.5
6"	3"	V-Groove Forged	6000	7-1/2"	75- VFR -0630-S		75- VFT -0630-S	1-5/16"	30.0
6"	3"	Rubber on Iron	680	7-1/2"	75- RIR -0630-S			1-5/16"	17.5
8"	2-1/2"	Cast Iron	2000	10-1/8"	75- CIR -0825-S		75- CIT -0825-S	2"	23.0
8"	2-1/2"	Durastan	2000	10-1/8"	75- DUR -0825-S			2"	15.0
8"	2-1/2"	Forged Steel	4500	10-1/8"	75- FSR -0825-S		75- FST -0825-S	2"	25.5
8"	2-1/2"	GT	2400	10-1/8"		75- GTB -0825-S		2"	15.0
8"	2-1/2"	Rubber on Iron-EHT	1005	10-1/8"	75- RIR -0825-S-EHT		75- RIT -0825-S-EHT	2"	18.5
8"	2-1/2"	Urethane on Iron	1800	10-1/8"	75- UIR -0825-S		75- UIT -0825-S	2"	18.5
8"	2-1/2"	V-Groove Iron	3000	10-1/8"	75- VIR -0825-S		75- VIT -0825-S	2"	27.0
8"	2-1/2"	Rubber on Iron	670	10-1/8"	75- RIR -0825-3			2"	18.5
8"	3"	Cast Iron	3000	10-1/8"	75- CIR -0830-S		75- CIT -0830-S	2"	26.0
8"	3"	Durastan	2500	10-1/8"	75- DUR -0830-S			2"	16.5
8"	3"	Forged Steel	5500	10-1/8"	75- FSR -0830-S		75- FST -0830-S	2"	26.0
8"	3"	Infinity	4000	10-1/8"		75- UIB -0830-S-INF		2"	20.0
8"	3"	Nylatron HD	6000	10-1/8"		75- NYB -0830-S		2"	16.0
8"	3"	Rubber on Iron-EHT	1680	10-1/8"	75- RIR -0830-S-EHT		75- RIT -0830-S-EHT	2"	19.5
8"	3"	Omega	1600	10-1/8"	75- UOR -0830-S		75- UOT -0830-S	2"	19.0
8"	3"	Urethane on Iron	2500	10-1/8"	75- UIR -0830-S		75- UIT -0830-S	2"	19.5
8"	3"	V-Groove Forged	6000	10-1/8"	75- VFR -0830-S		75- VFT -0830-S	2"	36.0
8"	3"	V-Groove Iron	5000	10-1/8"	75- VIR -0830-S		75- VIT -0830-S	2"	26.0
8"	3"	Rubber on Iron	840	10-1/8"	75- RIR -0830-S			2"	19.5
10"	2-1/2"	Cast Iron	2500	11-1/2"	75- CIR -1025-S		75- CIT -1025-S	2-3/16"	25.5
10"	2-1/2"	Durastan	2500	11-1/2"	75- DUR -1025-S			2-3/16"	16.5
10"	2-1/2"	Rubber on Iron-EHT	1185	11-1/2"	75- RIR -1025-S-EHT		75- RIT -1025-S-EHT	2-3/16"	21.5
10"	2-1/2"	Urethane on Iron	2370	11-1/2"	75- UIR -1025-S		75- UIT -1025-S	2-3/16"	21.5
10"	2-1/2"	Rubber on Iron	790	11-1/2"	75- RIR -1025-S			2-3/16"	21.5
10"	3"	Cast Iron	4000	11-1/2"	75- CIR -1030-S		75- CIT -1030-S	2-3/16"	23.0
10"	3"	Durastan	2900	11-1/2"	75- DUR -1030-S			2-3/16"	20.0
10"	3"	Forged Steel	6000	11-1/2"	75- FSR -1030-S		75- FST -1030-S	2-3/16"	41.0
10"	3"	GT	3400	11-1/2"		75- GTB -1030-S		2-3/16"	20.0
10"	3"	Infinity	5000	11-1/2"		75- UIB -1030-S-INF		2-3/16"	23.0
10"	3"	Nylatron HD	6000	11-1/2"		75- NYB -1030-S		2-3/16"	21.0
10"	3"	Omega	2000	11-1/2"	75- UOR -1030-S	75- UOB -1030-S	75- UOT -1030-S	2-3/16"	20.0
10"	3"	Rubber on Aluminum-EHT	2000	11-1/2"		75- RAB -1030-S-EHT	75- RAT -1030-S	2-3/16"	20.3
10"	3"	Rubber on Iron-EHT	2000	11-1/2"	75- RIR -1030-S-EHT		75- RIT -1030-S-EHT	2-3/16"	22.5
10"	3"	Urethane on Iron	3000	11-1/2"	75- UIR -1030-S		75- UIT -1030-S	2-3/16"	22.5
10"	3"	Ultra Thick Urethane	3400	11-1/2"	75- UTR -1030-S		75- UTT -1030-S	2-3/16"	25.0
10"	3"	V-Groove Forged	6000	11-1/2"	75- VFR -1030-S		75- VFT -1030-S	2-3/16"	48.0
10"	3"	V-Groove Iron	5000	11-1/2"	75- VIR -1030-S		75- VIT -1030-S	2-3/16"	23.0
10"	3"	Rubber on Iron	1000	11-1/2"	75- RIR -1030-S			2-3/16"	22.5
12"	2-1/2"	Durastan	3000	13-1/2"	75- DUR -1225-S			2-5/8"	20.5
12"	2-1/2"	Rubber on Iron	900	13-1/2"	75- RIR -1225-S			2-5/8"	23.5
12"	2-1/2"	Urethane on Iron	2700	13-1/2"	75- UIR -1225-S		75- UIT -1225-S	2-5/8"	23.5
12"	3"	Cast Iron	5000	13-1/2"	75- CIR -1230-S		75- CIT -1230-S	2-5/8"	32.0
12"	3"	Durastan	3500	13-1/2"	75- DUR -1230-S			2-5/8"	22.5

12"	3"	Rubber on Aluminum-EHT	2280	13-1/2"		75- RAB -1230-S-EHT	75- RAT -1230-S	2-5/8"	24.5
12"	3"	Rubber on Iron-EHT	2280	13-1/2"		75- RIR -1230-S-EHT	75- RIT -1230-S-EHT	2-5/8"	26.5
12"	3"	Urethane on Iron	3400	13-1/2"		75- UIR -1230-S	75- UIT -1230-S	2-5/8"	26.5
12"	3"	Ultra Thick Urethane	4100	13-1/2"		75- UTR -1230-S	75- UTT -1230-S	2-5/8"	28.0
12"	3"	VGroove Iron	6000	13-1/2"		75- VIR -1230-S	75- VIT -1230-S	2-5/8"	43.0
12"	3"	Rubber on Iron	1140	13-1/2"		75- RIR -1230-S	75- RIT -1230-S	2-5/8"	26.5

To order a rigid caster, change the "S" to "R" in the model number. For example: "75-CIR-1030-R". To order a rig only, omit the blue letters. For example: "75-1030-S". Dimensions shown are nominal. If precise dimensions are required, consult your RWM representative. For approximate weight of our rigid caster, deduct 3.9 pounds.

* Subtract 1/16" OAH when using this top plate

** Add 1/16" OAH when using this top plate

*** Add 3/16" OAH when using this top plate