

SCHOTT
glass made of ideas

NEXTREMA®

Glass-ceramics engineered
and designed for extreme
conditions





SCHOTT is a leading international technology group in the areas of specialty glass and glass-ceramics. With more than 130 years of outstanding development, materials and technology expertise we offer a broad portfolio of high-quality products and intelligent solutions that contribute to our customers' success.

This is also what the SCHOTT NEXTREMA® brand stands for. With high-performance glass-ceramic, SCHOTT offers a portfolio of materials that opens completely new fields of application for engineers and designers with its exceptional technical properties. As a real multi-talent, NEXTREMA® demonstrates what makes glass-ceramic a ground-breaking and unique solution, particularly in high temperature environments.

Contents

4	Glossy functionality	18	Surface resistance and gas impermeability
6	Brilliant use of form	20	Process inert
8	An all-round talent, seven features	22	Robustness at high temperatures
10	Operating temperature up to 950 °C	24	Ideas for the future with NEXTREMA®
12	Minimal thermal expansion	28	The 4 NEXTREMA® types of material
14	Thermal shock resistance	32	Standard forms of delivery
16	Wide transmittance spectrum	35	Technical features

NEXTREMA® Glossy functionality

In the construction of technical applications, your main concerns are physical and chemical parameters, robustness under extreme temperature loads and high chemical resistance.

The material decides if an idea will be implemented or not. With NEXTREMA®, we offer you a high-tech material with a variety of features. Particularly in high-temperature environments, where other materials such as plastic, conventional glass or metal show their limitations, NEXTREMA® is your new alternative.

Are you ready for innovative developments? Then start thinking of solutions never seen before.



In the following pages, next to this icon, engineers can discover potential ideas for the future.



NEXTREMA® Brilliant use of form

Colours and shapes are your world. You know that design is crucial for innovation and differentiation.

With NEXTREMA® glass-ceramic, we are offering you a high-tech material in the most varied colours, shapes and appearances. For an innovative product and industrial design under exceptional conditions, whether transparent, tinted, translucent or opaque – NEXTREMA®, the new material, will give your design a ground-breaking face.

Open the limits of what is possible and imagine how visual and technical design can function in a high-temperature environment.



In the following pages, next to this icon you will find suggestions for your future design ideas.

An all-round talent, seven features

The basis of NEXTREMA® is formed by seven features. Each feature individually or particularly combined can lead to new technical developments and fields of application. You will find the unique product features in the top half of this brochure. An impulse to produce ideas for the future is given in the lower half of the brochure. Perhaps you will soon be using NEXTREMA® in your research, development or production?

- 1
Operating temperature up to 950 °C (1,742 °F)
- 2
Minimal thermal expansion
- 3
Thermal shock resistance
- 4
Wide transmittance spectrum
- 5
Surface resistance and gas impermeability
- 6
Process inert
- 7
Robustness at high temperatures

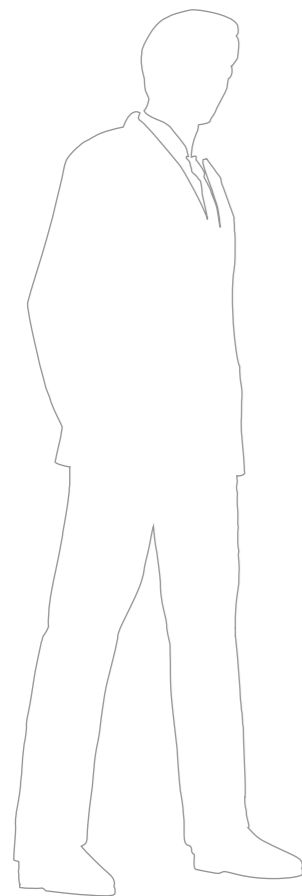

The engineer

What benefits does NEXTREMA® offer engineers?

Would you like to find out what technical possibilities NEXTREMA® offers? In the following pages, you will find an overview of what can be done in the future.



The designer

What benefits does NEXTREMA® offer designers?

Let your imagination run free. In the following pages, you will learn the kind of potential a high-tech material like NEXTREMA® can offer your industrial and product design.

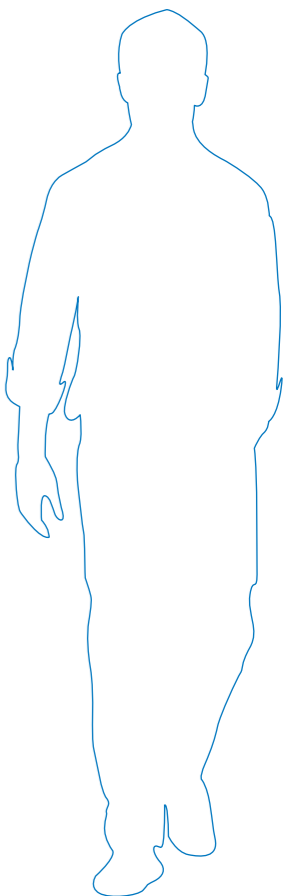

We would like to rouse your imagination for potential ideas for the future. The innovations presented are not finished products, but rather visions of applications we do not yet know of, but may be possible tomorrow with your ideas.

Feature 1: Operating temperature up to 950 °C

Warm, warmer, hot: NEXTREMA® glass-ceramic shows its real strength under conditions of extreme temperatures. We have the right type of NEXTREMA® for the widest range of temperatures – guaranteed up to 950 °C (1,742 °F).

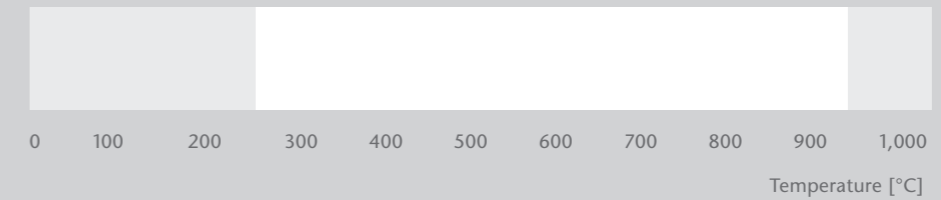

Idea for the future 1: Improve and observe hot processes



Hot on development

You can realize intelligent concepts using NEXTREMA® particularly in the production of semiconductors and displays. Examples include inner lining and heat shields in high temperature industrial ovens. Or why not use NEXTREMA® as carrier plates and process boxes for complex coating processes in the semiconductor or solar industry.



High temperature industrial processes take a new form with NEXTREMA®.



With an eye for what's important

When you see mistakes with the naked eye, you can react more quickly. NEXTREMA® stands for a new level of transparency, such as in the observation of internal high temperature processes. The strength and size of NEXTREMA® offers you a greater freedom of design.

Feature 2: Minimal thermal expansion

The innovative potential is expanded with NEXTREMA®, not the material itself. The intelligent microstructure of NEXTREMA® results in near zero expansion, enabling the glass-ceramic to keep its shape in a high temperature environment.

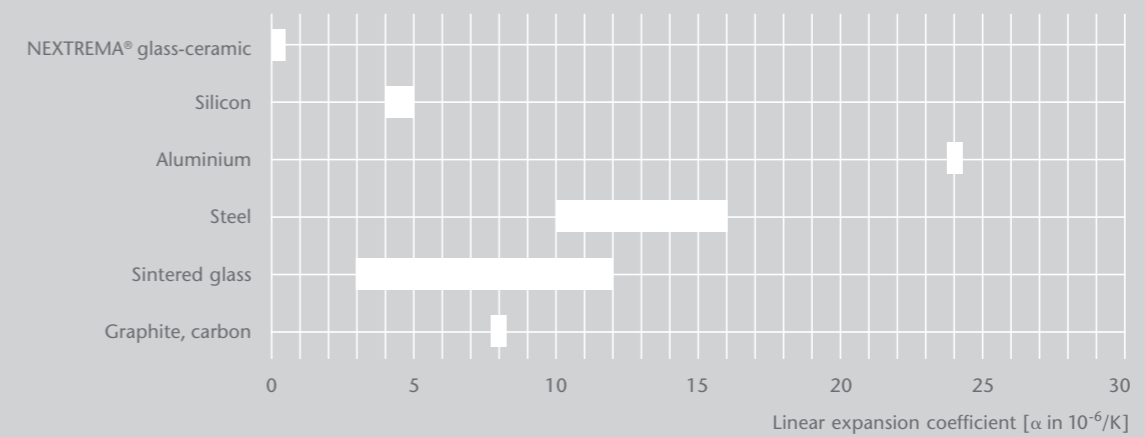

Idea for the future 2: Accuracy in extreme conditions



Maximum load and still stress-free

Where there are high temperature fluctuations within a short time along with the strictest requirements for precise maintenance of size, NEXTREMA® is extremely resistant to external influences. Because there are no restrictions with material expansion even under extreme temperature conditions, NEXTREMA® can resolve many of your constructional issues.

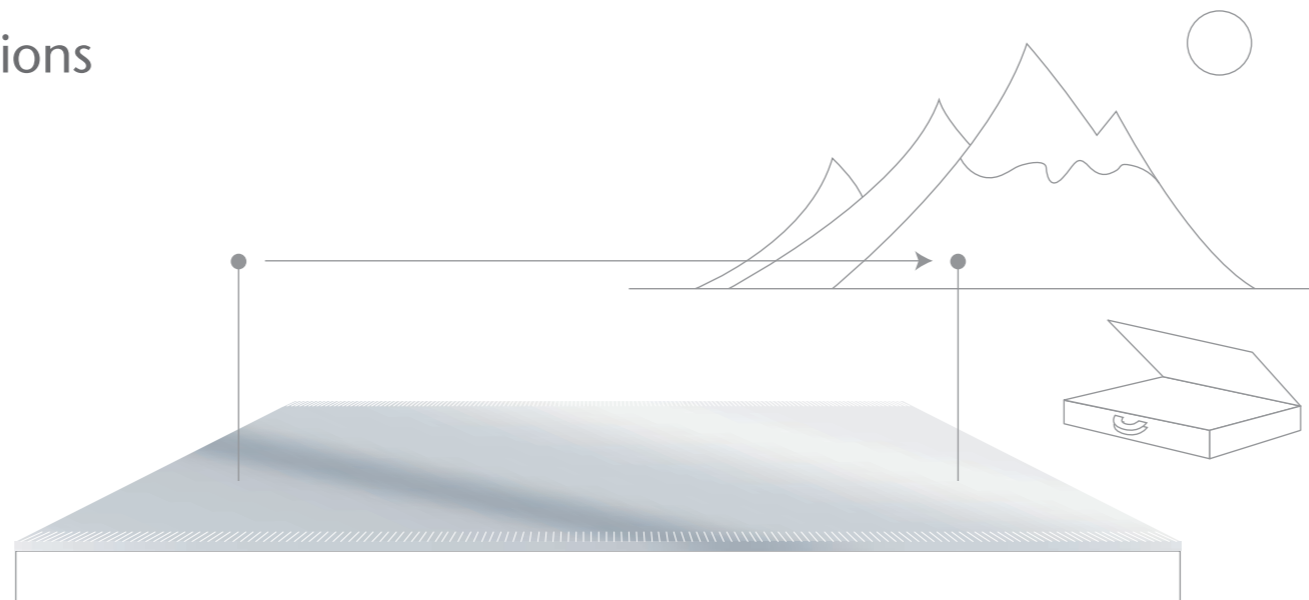

Always in top form

Deformations caused by extreme fluctuations in temperature can be almost completely eliminated due to the high dimensional stability of NEXTREMA®. The material's image and visual appearance do not change and bring consistency to your industrial design.

The near zero thermal expansion of NEXTREMA® „fixes“ measurement points despite extreme temperature fluctuations, increasing the accuracy of optical measurement technology.

Feature 3: Thermal shock resistance

Nothing shocks NEXTREMA®. Quick change of temperature? Fire and ice? Thanks to the thermal shock resistance of NEXTREMA®, thermal material failure is a thing of the past.

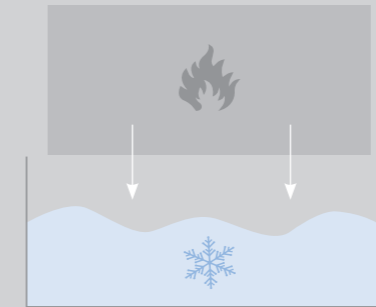

Sudden change of temperature of the material



Material remains free of tension between hot and cold

Idea for the future 3: Quick reaction heating systems for water and air



It delivers what it promises

Whether there are extreme temperature gradients or very fast heating and cooling phases for highly efficient processing times – NEXTREMA® remains stable. Where metal deforms, glass breaks and plastic can not resist the heat, NEXTREMA® is a reliable choice.

Possible areas of application? Imagine you are installing heating fins in an electrical car, what about heating the car interior with high performance heating technology, where only the material is heated with an intelligent coating on the fins.

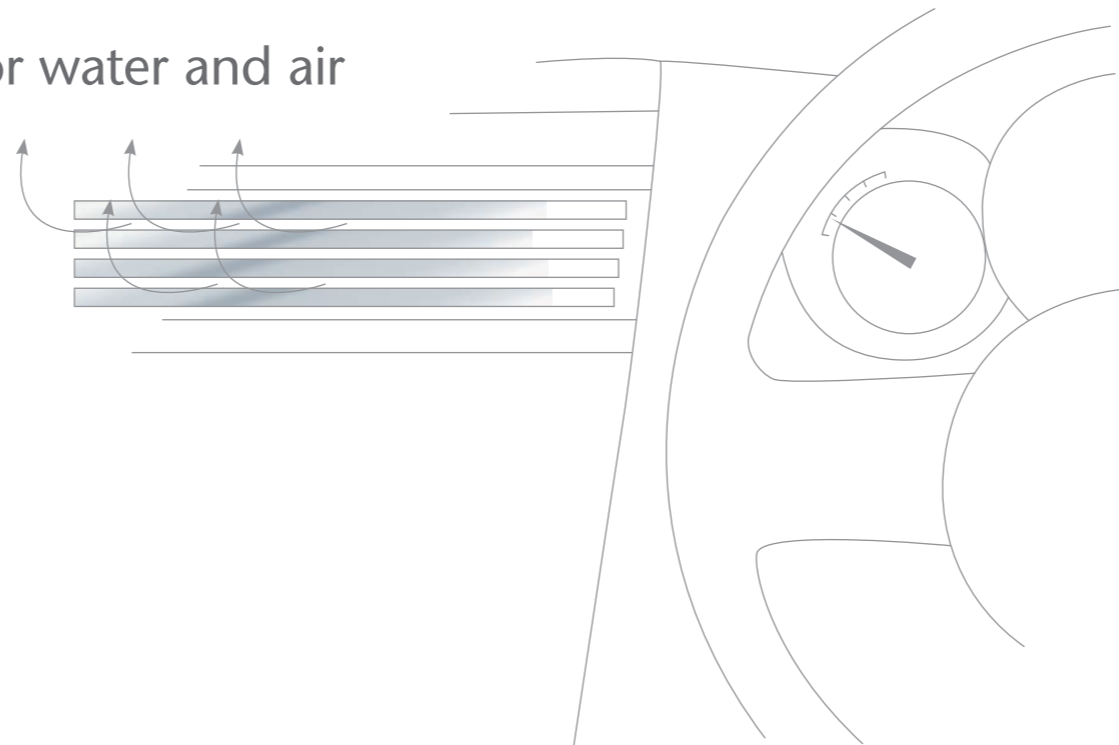

New functionality in trendsetting design: NEXTREMA® heating fins in electrical cars.



NEXTREMA® makes heat chic

For example, NEXTREMA® opens up completely new design possibilities for vehicle interiors. Here, where it is especially important to save space and weight, innovative technology meets great demand in new design. Electrical heating coating on NEXTREMA® means heating can be incorporated in the new design.

Feature 4: Wide transmittance spectrum

Specific to the type and thickness of NEXTREMA®, there are different transmission windows. These are important for certain technical applications and, in addition, give each material a unique appearance.

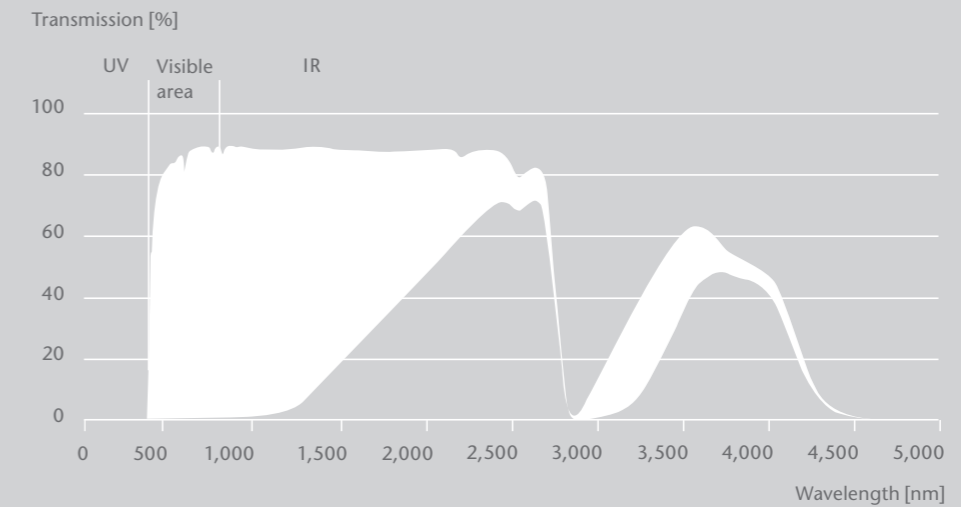

Idea for the future 4: Optimizing processes



Specific use of transmission windows

NEXTREMA® makes your visions for radiation in the future a reality: as a cover or filter for sources of heat radiation or used in IR drying equipment, disinfection equipment, IR sauna cabins, as component of UV protection or for efficient heating of substrates.

NEXTREMA® in IR paint drying equipment – discover a new dimension of application.

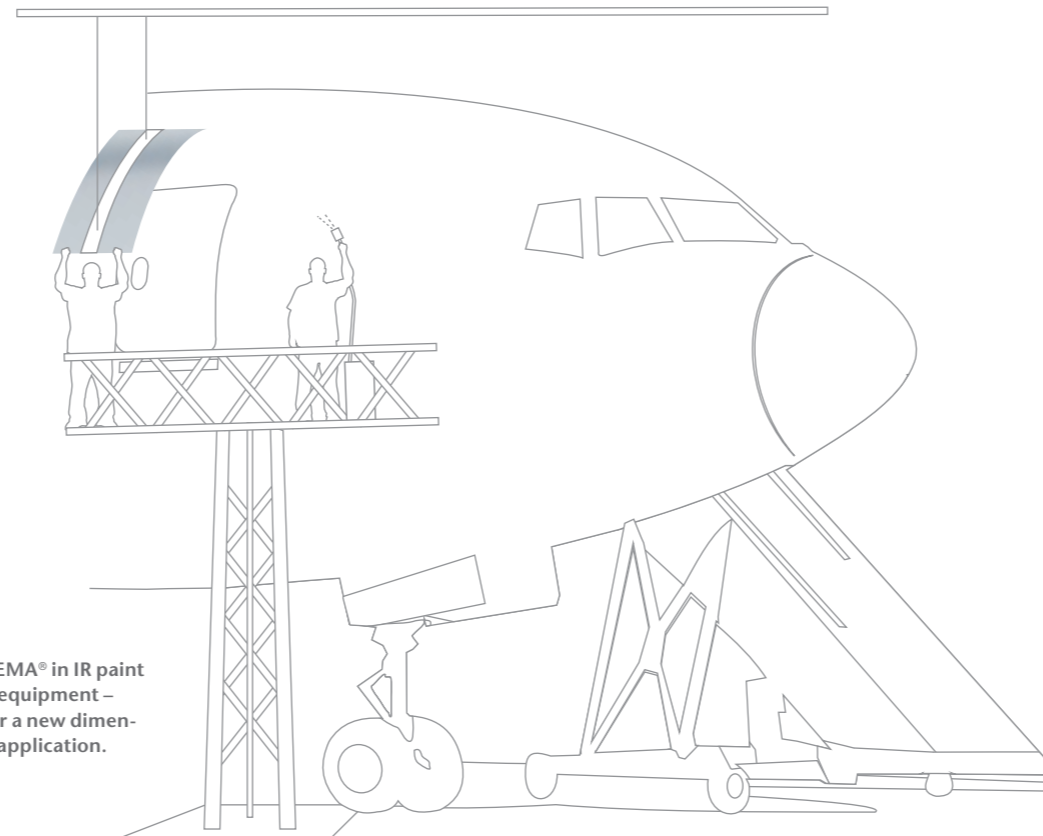

Ideas in the right light

Different transmission windows produce different colours and appearances of glass-ceramics. Let your imagination run free and discover a new range of possible applications in the visible and/or IR area.

Feature 5: Surface resistance and gas impermeability

Thanks to its unique surface finish, NEXTREMA® has multiple resistance to acids and bases. This means it can be used in aggressive environments.

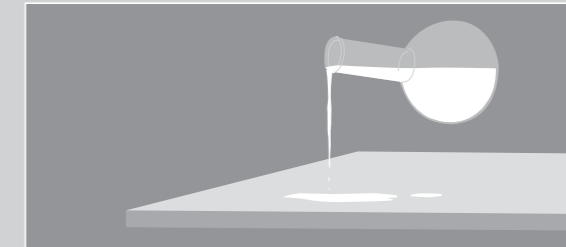

Idea for the future 5: Energy efficiency in an aggressive environment



Attacking is futile

Acids, bases and aggressive gases don't stand a chance with NEXTREMA®. Use NEXTREMA® where absolute surface resistance is required – such as for shielding or coating under chemically aggressive conditions.

For the production of accumulators, for acidic or alkaline cleaning processes in the semiconductor industry or for heat exchangers in corrosive environments, NEXTREMA® can become your efficient solution.

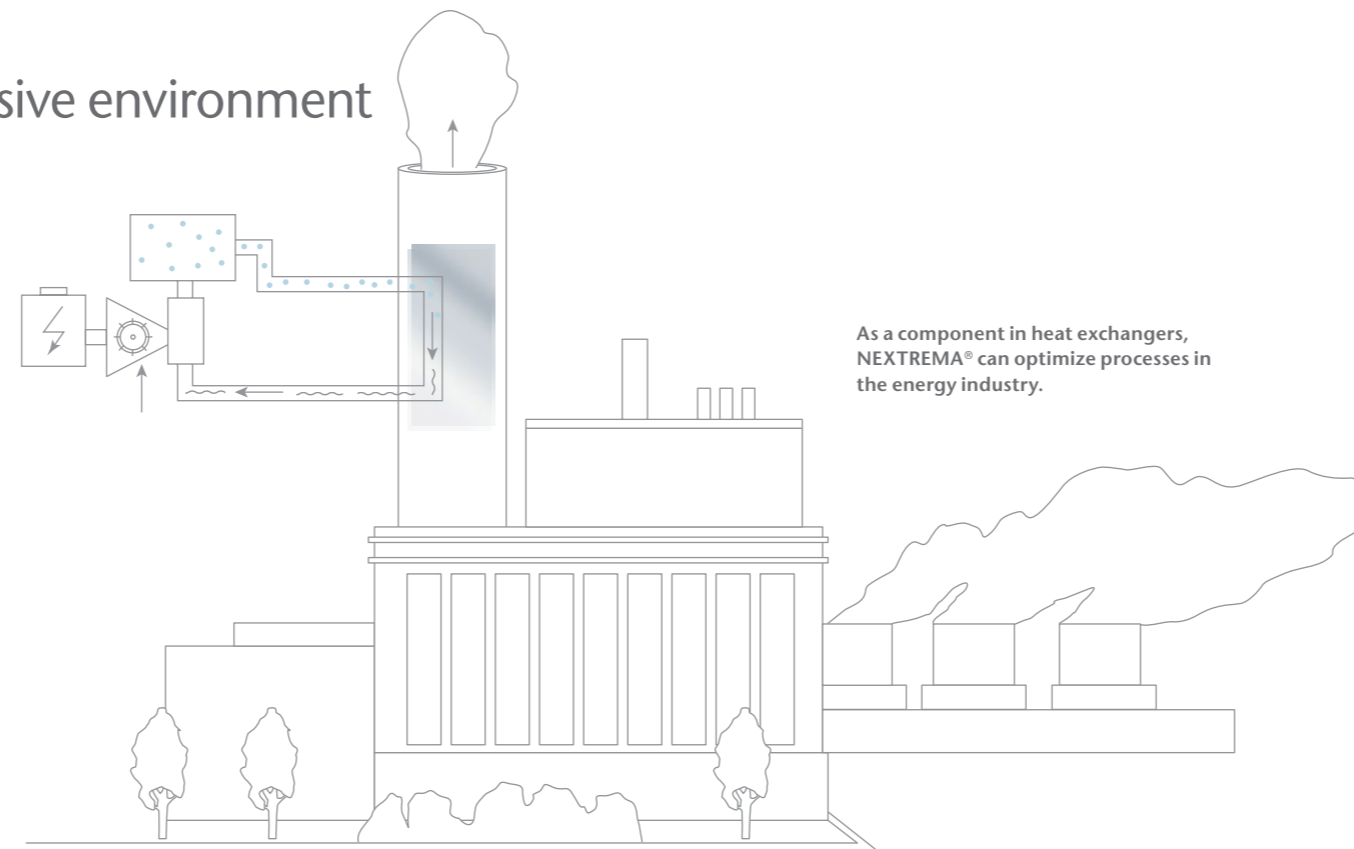

Superior in every environment

With NEXTREMA®, a new generation of devices is taking shape. Where longevity and beauty had until not been feasible, elegant and high product aesthetics are now possible with NEXTREMA® – even in aggressive environments.

Feature 6: Process inert

Without discussion: NEXTREMA® is process inert. Even under extreme conditions, the material will not have negative interactions with the process environment. There are no interfering process factors such as gas emissions from organic components.

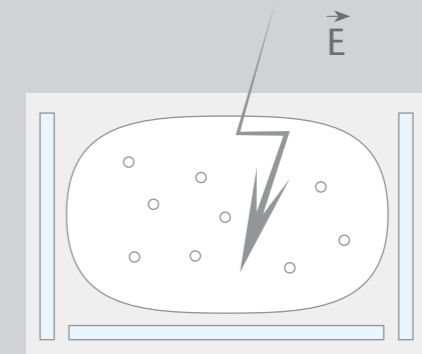

PECVD (500 - 700 °C / vacuum)
PECVD (932 - 1,292 °F / vacuum)

Idea for the future 6: Coating of the highest purity



Uncompromising in use

With NEXTREMA®, you have a material that guarantees the highest purity, because it has double security in the coating process: NEXTREMA® does not give off nor absorb any components.

Whether for plasma-enhanced chemical vapour deposition (PECVD), for plasma etching or the production of cathodes for lithium-ion batteries, NEXTREMA® will soon be effectively used in many areas and sectors.



Ground-breaking technical design

Develop a new design for carrier plates in coating processes or take a new creative path in the coupling of coating and cleaning processes.

NEXTREMA® is a versatile material that can make your design a sought after solution in many areas of coating technologies.

Process inert NEXTREMA® glass-ceramic is perfect as a carrier material for plasma coating and etching.

Feature 7: Robustness at high temperatures

Strong under heat: NEXTREMA® exceeds where other materials fail. This is why exceptionally high mechanical stability under high temperatures is important. It makes the crucial difference even with thin plates in large formats.

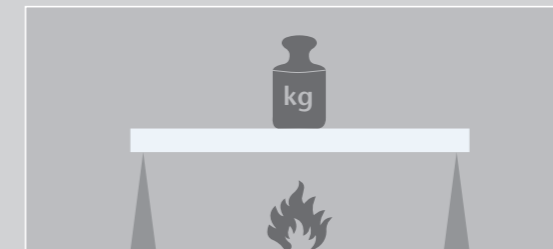

Mechanical stability of NEXTREMA® at high temperature

Idea for the future 7: Discover new worlds



Resistance is futile

Thanks to its mechanical robustness at high temperatures, NEXTREMA® glass-ceramic is your new alternative. For example, in the production of heat shields or inner linings of high temperature industrial processes, show strength in even the hottest environments with NEXTREMA®.

Glass-ceramic for outer space? Still science fiction today – but it could become a reality tomorrow. Launch into new dimension of construction with NEXTREMA®.

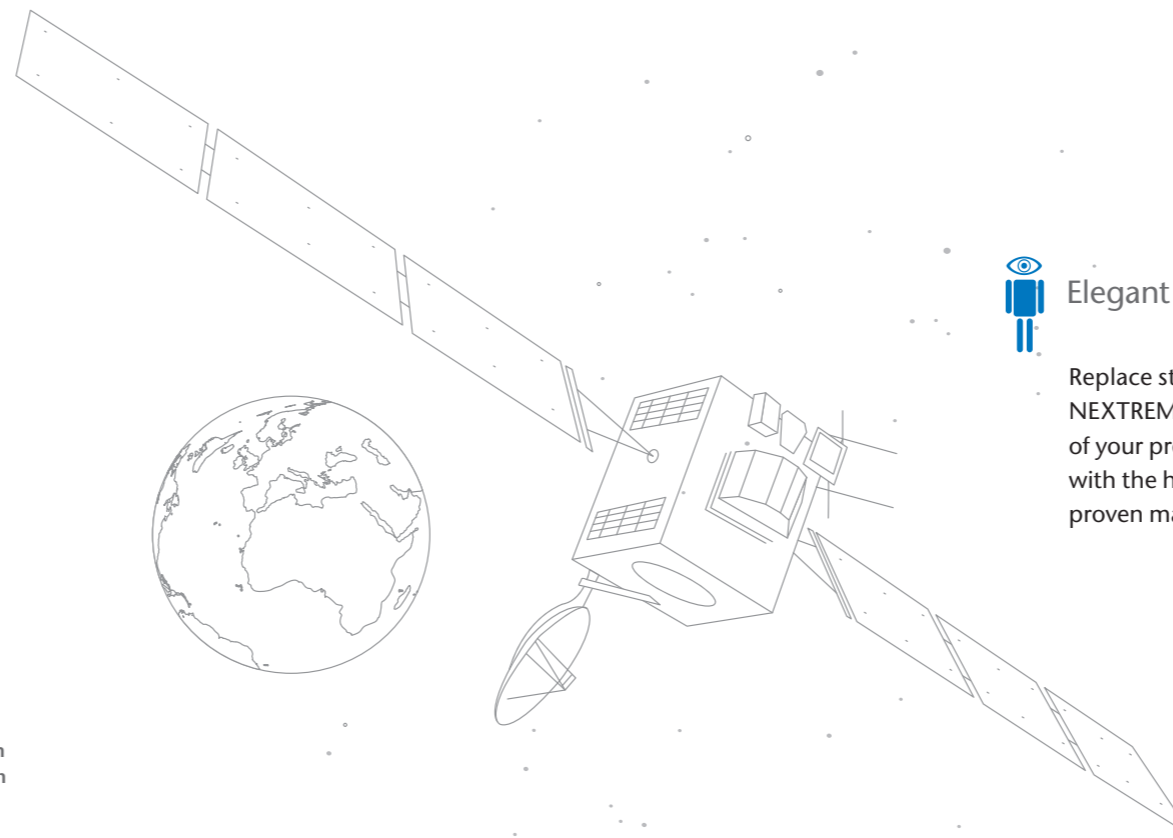

Elegant safety

Replace standard high temperature materials with NEXTREMA® glass-ceramic and redesign the appearance of your product. NEXTREMA® offers a unique impression with the highest possible level of functionality and is a proven material in many areas.

Ideas for the future with NEXTREMA®

From the material to the product – NEXTREMA® opens new dimensions in development for engineers and designers. Let yourself be inspired. The examples on these pages show the possibilities – or what could become possible in the distant future. Bring your ideas for the future to us.

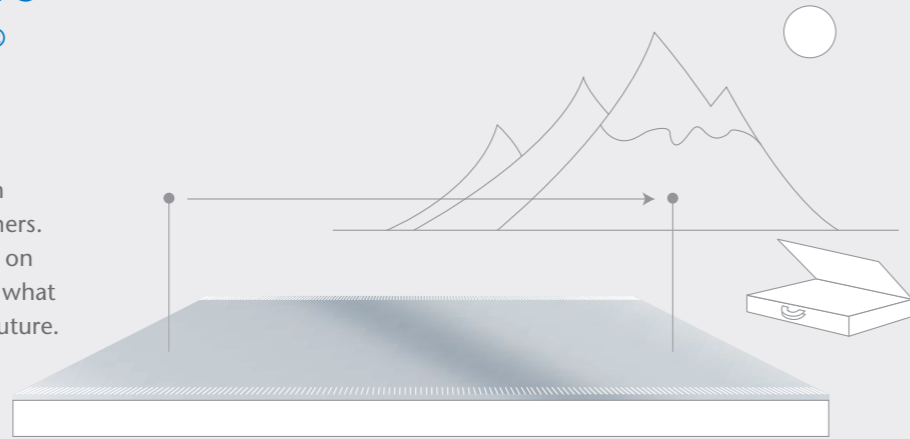

Precision at the highest level

Precise measurement results even with extreme temperature fluctuations: The measuring table with the NEXTREMA® surface

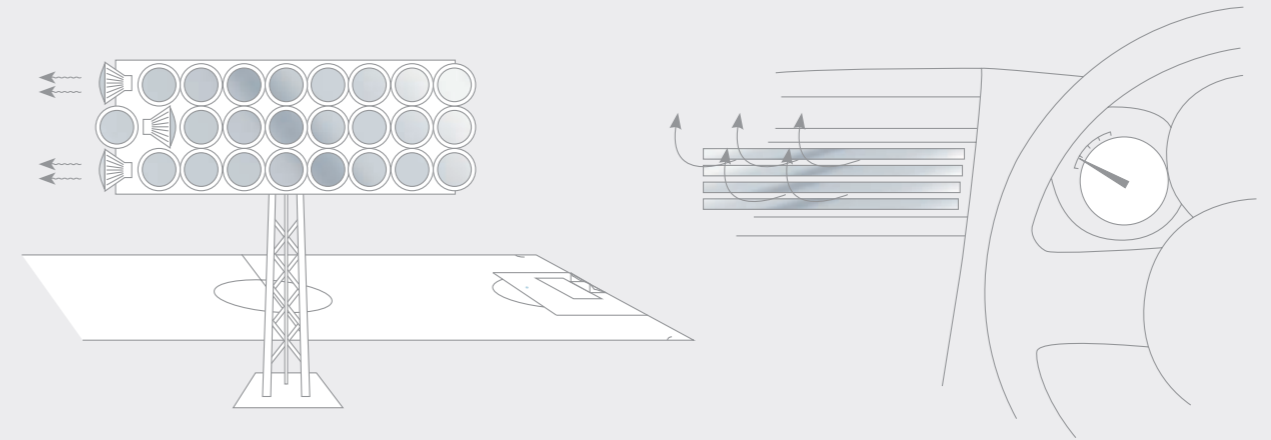

Wind and weatherproof

Flood light cover screens with NEXTREMA®

Efficient in a new design

NEXTREMA® heating fins for heat and clear visibility in electrical cars



Beautiful & safe heat

NEXTREMA® upgrades design and protection level of IR heaters in both patio and industrial applications.

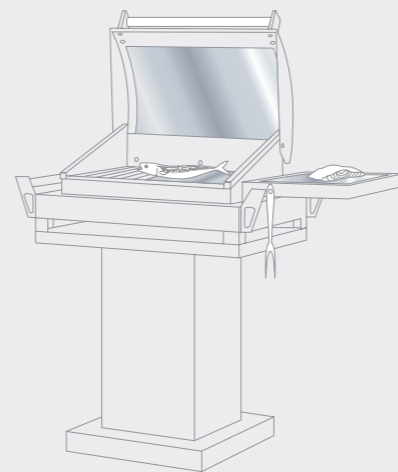

A better way to grill

NEXTREMA® for BBQ Grills creates a better grilling experience

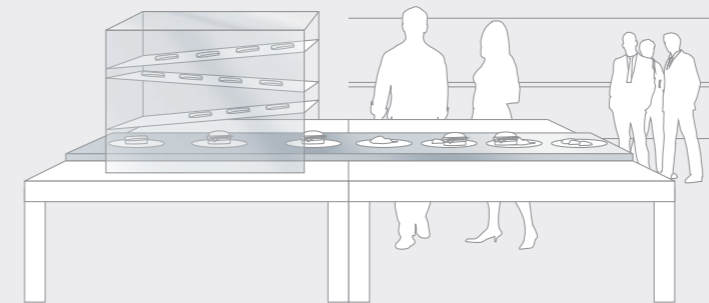

Process observation

Innovative perspectives for food technology



Breath-taking heating technology

Electrical heating systems on NEXTREMA® as the substrate

Ideas for the future with NEXTREMA®

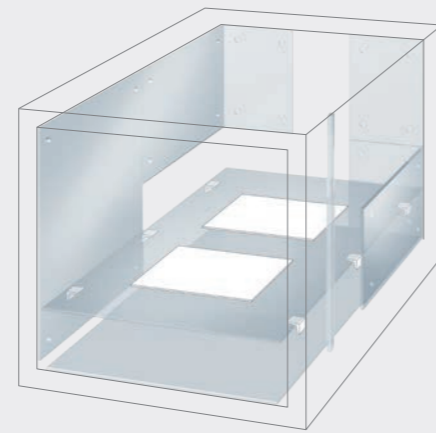

Process inert at high temperature

NEXTREMA® as a carrier plate or inner lining for high temperature furnaces used in FPD and solar panel manufacturing.

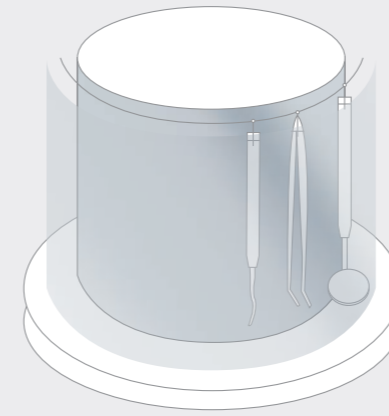

Lab technology with know-how

NEXTREMA® makes heat efficient in sterilizing processes

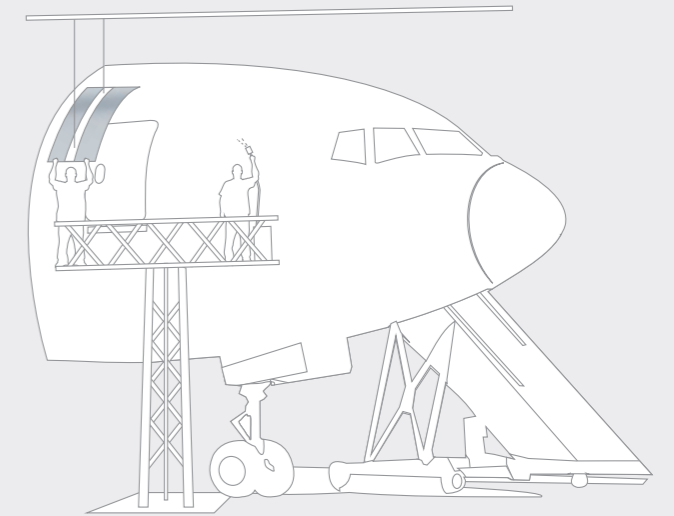

Efficient drying

NEXTREMA® in IR paint drying equipment

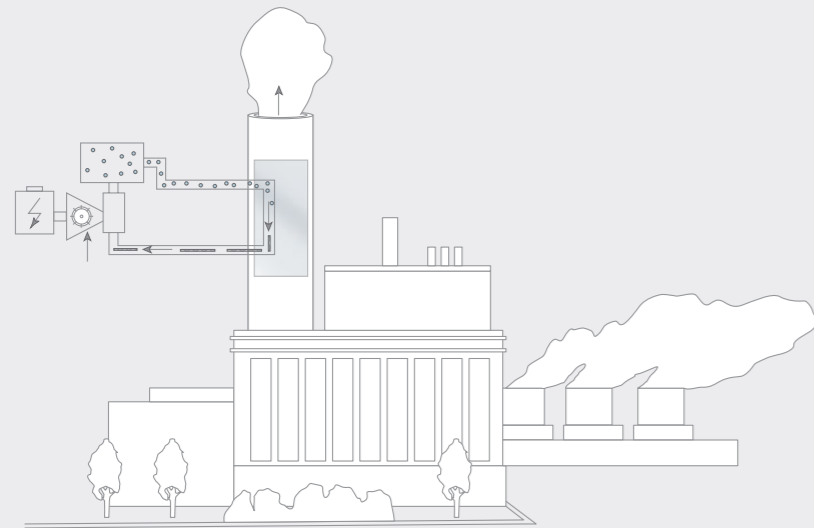

Recovering energy

NEXTREMA® as a component in exhaust gas recovery

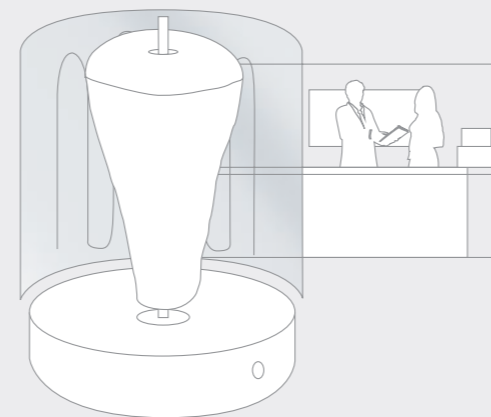

Service for the food sector

Hygienic, attractive, efficient: NEXTREMA® revolutionizes roaster technologies



Design-oriented technology

Ground-breaking heating technology - for water too

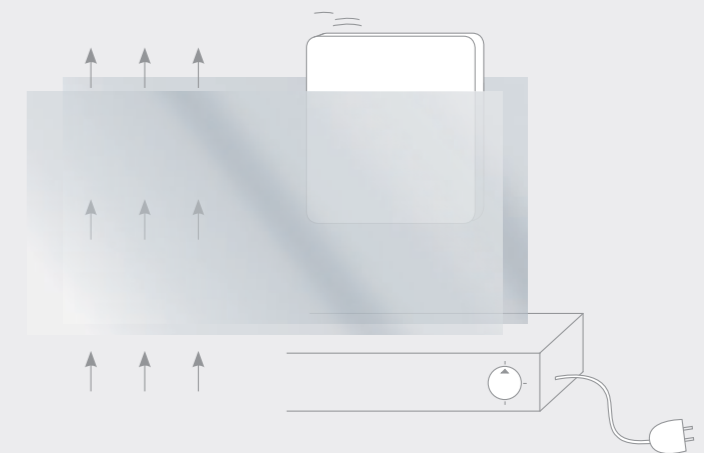

Progress with vision

The glass-ceramic toaster makes design an experience

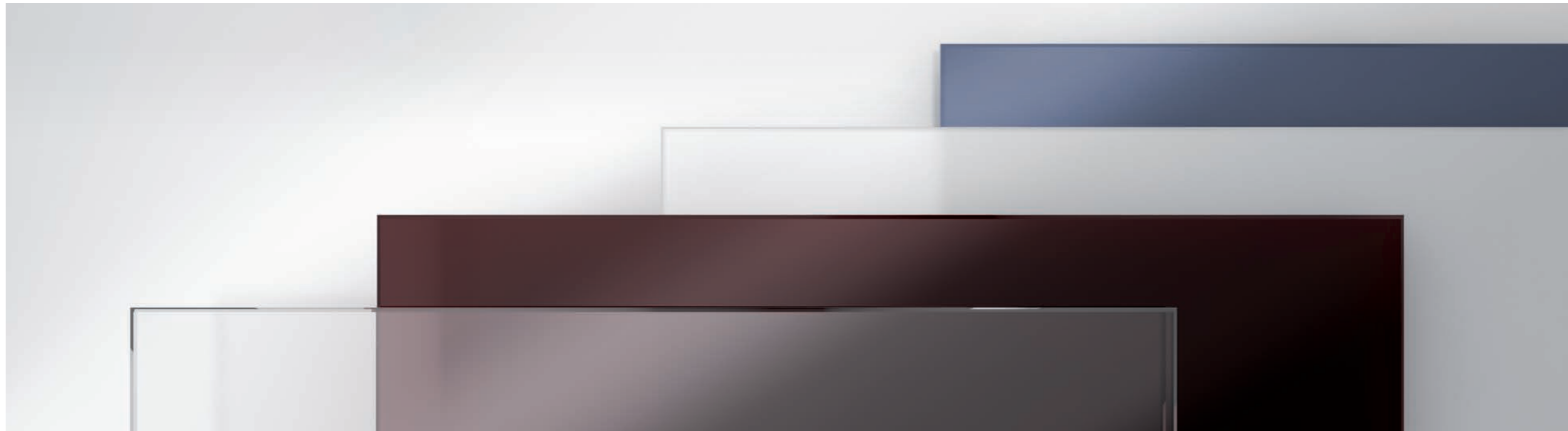

All four NEXTREMA® types at a glance

The 4 NEXTREMA® types of material

No NEXTREMA® is like another. We would like to supply you with glass-ceramic that corresponds to your requirements as precisely as possible. This is why NEXTREMA® is available in four types, each with different benefits.

SCHOTT NEXTREMA® transparent

The transparent variety keeps a clear head in extreme temperature environments. Particularly in infrared applications, where the material must also have the best transparency in addition to high thermal robustness, NEXTREMA® transparent is a material made to measure.

SCHOTT NEXTREMA® tinted

NEXTREMA® tinted stands out with three prominent material features: high temperature resistance, high mechanical stability, and optimized transmittance of wavelengths for infrared.

SCHOTT NEXTREMA® translucent

Thanks to its ideal insulation properties, NEXTREMA® translucent is generally the number one material where high insulation properties are required in extreme temperature environments. The fact that this type of NEXTREMA® also has excellent resistance against chemical attacks makes it an even more sought after solution.

SCHOTT NEXTREMA® opaque

Besides its surface resistance, NEXTREMA® opaque glass-ceramic impresses due to its absolutely dense and pore-free surface. Both show why NEXTREMA® also plays a significant role from an aesthetic perspective. The noble opaque white sets an example.

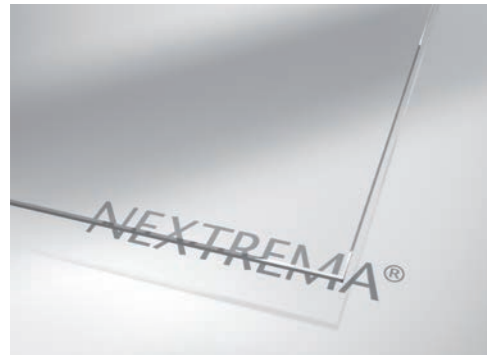

NEXTREMA® transparent

All materials at a glance

SCHOTT NEXTREMA® transparent

The transparent glass-ceramic offers the advantage of being high temperature resistant along with allowing a clear view. In addition, it is highly permeable to thermal radiation, especially in the shortwave infrared range. As a result, transparent glass-ceramics can be ideal for applications requiring very high thermal strength in combination with good transparency.

Key features

- Near zero thermal expansion
- Excellent transparency
- Highly permeable to thermal radiation
- Water- and dirt-repellent in comparison to technical ceramics
- UV-filter

Exemplary application fields

- Carrier plates in CVD-furnaces
- Cover panels for heating elements and burners
- Cover panels for projectors/beamers/photocopiers
- Thermo-mechanical resilient glass (e.g. night-vision devices)
- Windows for combustion furnaces
- Interior panels of oven doors

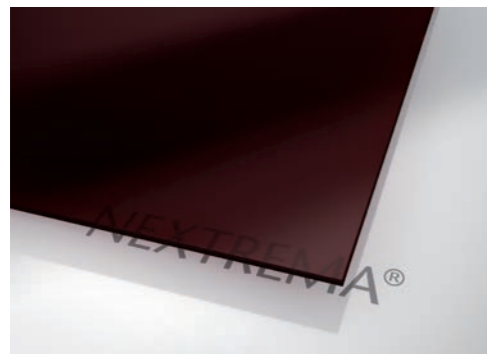

NEXTREMA® tinted

SCHOTT NEXTREMA® tinted

The tinted glass-ceramic has excellent temperature resistance in combination with high mechanical stability. Heat is transmitted very efficiently, with virtually no heat loss because of an almost exact heat permeability and a low thermal conductivity. The transmission of wavelength is optimized for the infrared range.

Key features

- Near zero thermal expansion
- Precise heat permeability
- Low thermal conductivity
- Mechanical stability
- System-optimized IR transmittance

Exemplary application fields

- Cover plates for (infrared) heating elements (e.g. IR drying plants)
- Carrier/protection plates for food-processing industry

SCHOTT NEXTREMA® translucent

Due to its low alkali content, translucent glass-ceramic has very unique insulating qualities. It is the ideal material for applications requiring an excellent insulator at high temperatures. In addition, this material meets highest standards on resisting chemical surface attacks.

Key features

- Excellent electrical volume resistance at high temperatures
- High chemical resistance
- High IR transmittance

Exemplary application fields

- Cover plates for (infrared) heating elements (e.g. IR drying plants)
- Lining for furnaces

SCHOTT NEXTREMA® opaque

The opaque glass-ceramic is distinguished by its excellent resistance to chemical surface attacks by acid, alkali or hydrolytic effects. In addition, opaque glass-ceramic exceeds due to its absolutely dense and pore-free surface, which is also dirt-repellent and suited for clean room conditions. Furthermore, this material can be used for applications requiring good insulating properties. Aesthetics play an important role for non-transparent glass-ceramics as well. The white appearance gives the material a noble and brilliant touch.

Key features

- Highest chemical resistance
- Dense and pore-free
- Thermal insulating properties
- Brilliant appearance
- High IR transmittance without blinding
- IR-A filter

Exemplary application fields

- Ceramic carrier plates for sputter and solar production
- Carrier/protection plates/baking stones for food-processing industry, i.e. microwave applications



NEXTREMA® translucent white

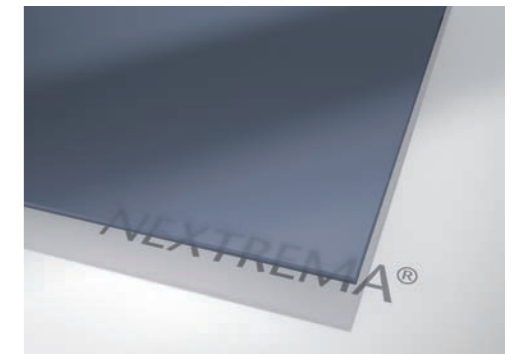

NEXTREMA® translucent bluegrey



NEXTREMA® opaque white



NEXTREMA® opaque grey

Standard forms of delivery

The current status of availability by material and form of delivery has to be requested by the customer. Not all combinations are producible. Other forms of delivery are available on request.

Flat panels

Format: Cut to size panels

- Length 50 mm – 1930 mm
- Width 50 mm – 1075 mm
- Diameter 20 mm – 1075 mm
- Thickness (standard) 2 mm – 6 mm
- On request 8 mm – 16 mm

Mechanical treatment

- Grinding profile Seamed, C-, U-, V-shape, others on request
- Drilled borehole \varnothing 10 mm – \varnothing 200 mm
- Bevelled edges (width) 5 mm – 20 mm

Overview of dimensions: Cut to size panels

	Standard length	Standard width	Profile
Thickness	Min. - Max.	Min. - Max.	
2 mm	50 – 1555 mm	50 – 860 mm	On request
3 mm	50 – 1930 mm	50 – 1075 mm	C, U, V
4 mm	50 – 1930 mm	50 – 1075 mm	C, U, V
5 mm	50 – 1930 mm	50 – 1075 mm	C, U, V
6 mm	50 – 1930 mm	50 – 1060 mm	C, U, V
≥ 8 mm	50 – on request	50 – 960 mm	C, U, V

Forms of delivery

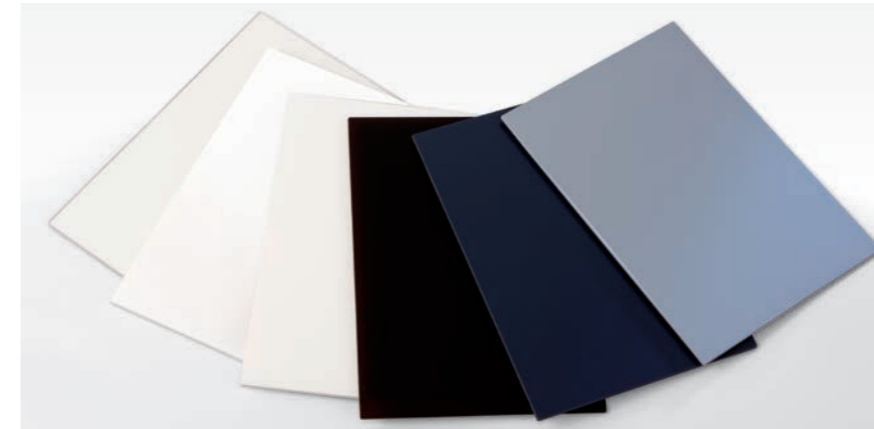

Grinding profiles

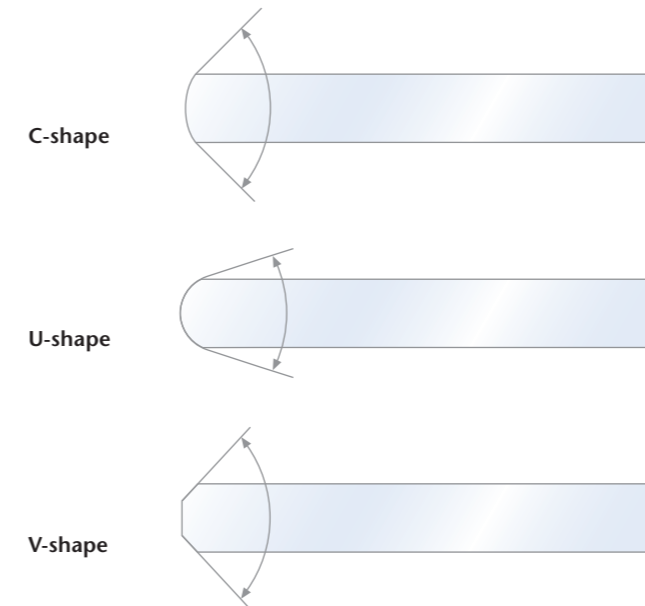

Bent panels

Formats of bent panels must be requested. Various forms are available.



Dimensional tolerances and material defects

With regard to the specific format all of the following characteristics refer to the net-size, as agreed upon with the customer. Other forms of delivery are available on request.

Dimensional tolerances of flat, cut to size panels

Characteristics / Areas / Location	Tolerance
Thickness t	
t = 2.0 mm	± 0.3 mm
t = 3.0 / 4.0 / 5.0 mm	± 0.2 mm
t = 6.0 mm	± 0.3 mm
Edge length l	
l ≤ 500 mm	± 1.0 mm
500 mm < l	± 1.5 mm
Squareness (ISO 1101) (depending to the edge length l)	
l ≤ 500 mm	≤ 1.0 mm
500 mm < l	≤ 1.5 mm
Flatness along the diagonal D (depending on edge length l)	
on request	
Corner radius r	
r ≤ 5 mm	± 0.5 mm
5 mm < r ≤ 20 mm	± 1.0 mm
20 mm < r	± 2.0 mm
Drilled holes	
Diameter of drilled holes	± 0.5 mm
Borehole position to reference	± 1.5 mm

Dimensional tolerances

Technical features

All technical data presented in this material specification must be understood as typical average values. Detailed information on the different material types is documented in separate data sheets or will be provided on the customer's special request. Specifications are subject to change without prior notice.

Values, for which no generally accepted measuring method exist, such as by a technical standard, are specified and explained.

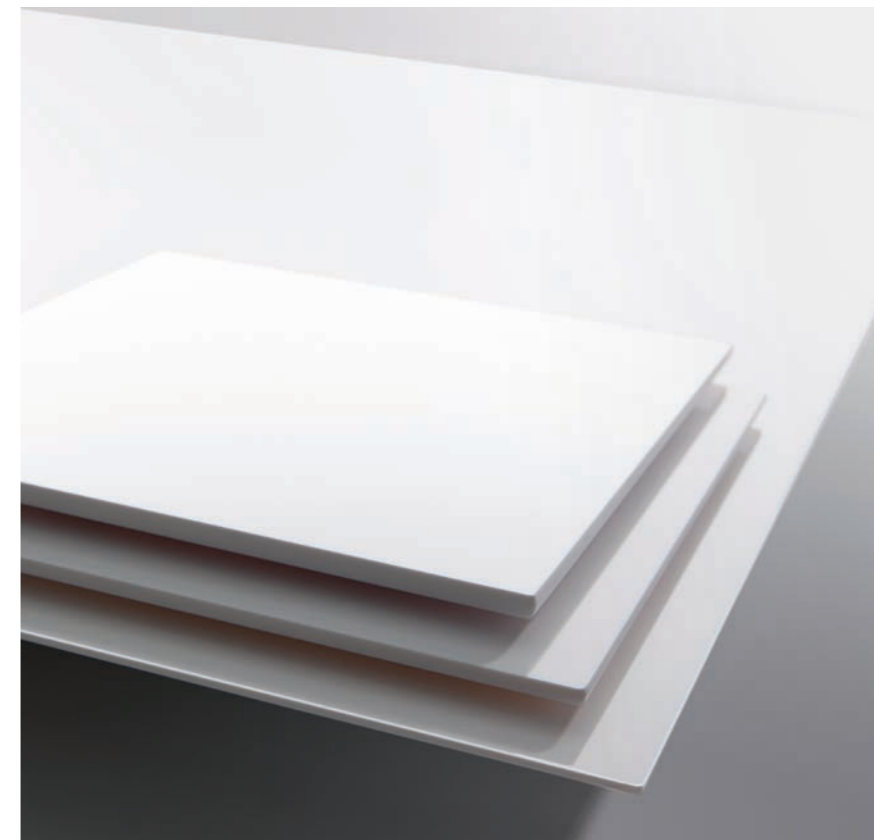

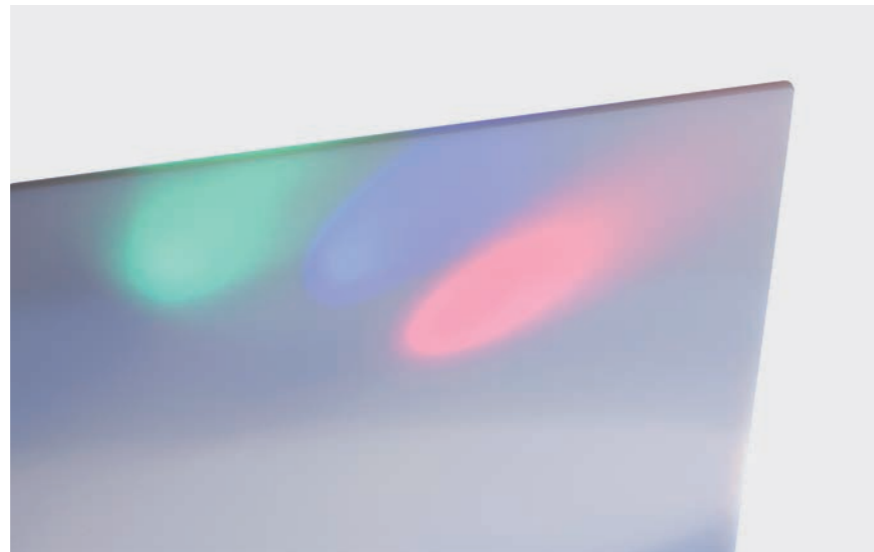

Optical characteristics

General appearance

Transparent, translucent white, opaque white, opaque grey, tinted.
One-sided nubs are available on request.

The surface texture depends on the thickness.
Polishing process provides “window glass” appearance.
Decoration is available on request.

Transmission

The transmission values are measured for a polished sample of a specific thickness.

- NEXTREMA® opaque white
- NEXTREMA® tinted
- NEXTREMA® translucent bluegrey
- NEXTREMA® transparent
- NEXTREMA® translucent white
- NEXTREMA® opaque grey

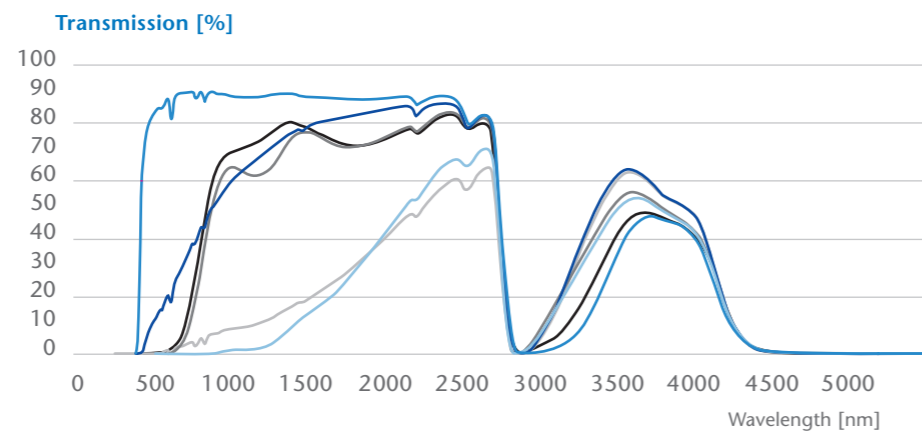

This graph is based on data from individual measurements. Deviations may result from manufacturing process. Typical transmission graph of different ceramization states with sample thickness of approximately 4 mm.

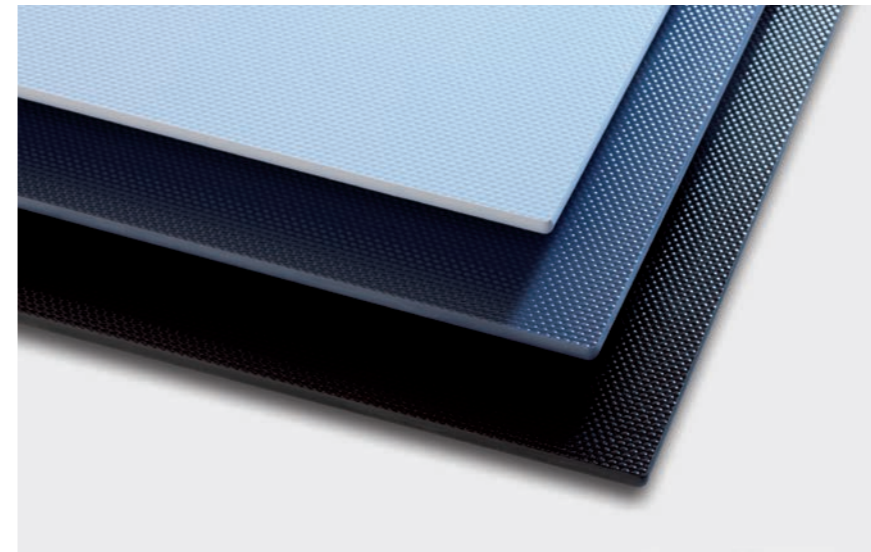

Mechanical characteristics [at room temperature]

ρ approx. 2.5 – 2.6 g/cm³

Density

E approx. 84 – 95 x 10³ Mpa

Modulus of elasticity
(ASTM C-1259)

μ approx. 0.25 – 0.26

Poisson's ratio
(ASTM C-1259)

HK_{0.1/20} approx. 570 – 680

Knoop hardness
(ISO 9385)

σ_{bb} approx. 100 – 160 Mpa

Bending strength
(DIN EN 1288, Part 5, R45)

The impact resistance of NEXTEMA® depends on the kind of installation, size, thickness and geometry of the panel, type of impact and especially on drilled holes and their position in the material.

Impact resistance

Therefore, information regarding impact resistance can only be given with knowledge of the respective and defined application (especially in combination with the technical standards regarding impact resistance that have to be met for some applications). The quality of the grinding profile has an important influence according to the impact resistance.

0 %

Porosity (ISO 9385)

Material 724-3 (t = 4 mm)

$R_a \leq 0.20 \mu\text{m}$
 $R_{ms} \leq 0.25 \mu\text{m}$

Roughness

Thermal characteristics

Coefficient of linear thermal expansion (DIN ISO 51045-1, DIN ISO 7991)

In certain applications, the coefficient of mean linear thermal expansion and therefore the total change of length of a NEXTREMA® part within a specified temperature range is important to its function. The following mean coefficient values and the graph show the temperature dependency.

CTE in different temperature ranges	
α (-50 °C; 100 °C)	$-0.8 - 0.6 \times 10^{-6} \text{ K}^{-1}$
α (0 °C; 50 °C)	$-0.8 - 0.6 \times 10^{-6} \text{ K}^{-1}$
α (20 °C; 300 °C)	$-0.4 - 0.9 \times 10^{-6} \text{ K}^{-1}$
α (300 °C; 700 °C)	$0.1 - 1.6 \times 10^{-6} \text{ K}^{-1}$

Thermal expansion in dependence on the temperature

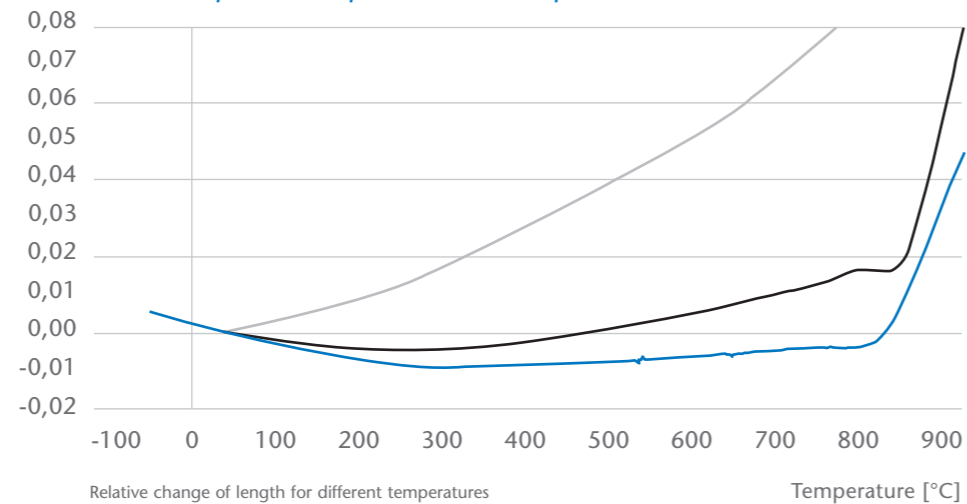

— NEXTREMA® tinted
— NEXTREMA® transparent
— NEXTREMA® opaque white

Specific heat capacity

$$C_{p(20-100\text{ °C})} \mathbf{0.80 - 0.85 \text{ J / (g x K)}}$$

Thermal conductivity
(DIN 51936, ASTM E 1461-01)

$$\lambda_{(90\text{ °C})} \mathbf{1.5 - 1.7 \text{ W / (m x K)}}$$

MTG 400 – 800 K

Resistance of the material to temperature differences between a defined hot zone and cold edge of room temperature, without cracking due to thermal stress.

Maximum temperature gradient (MTG)

TSR 700 – 820 °C (1,292 - 1,508 °F)

Resistance of the material to thermal shock when the hot material is splashed with cold water at room temperature, without cracking due to thermal stress.

Thermal shock resistance (TSR)

The temperature / time load capacity specifies the maximum permissible temperatures for load times of the material, below which no cracking should occur due to thermal stress. The temperature / time load data for uneven and even temperature distributions (e.g. homogeneous heating conditions) within the material are different.

Temperature/time load capacity (TTLC)

Homogeneous heating of the material

TTLC / Short term load (1h)	[°C] 880 – 950 / [°F] 1616 – 1742
TTLC / Continuous load (5000 h)	[°C] 700 – 850 / [°F] 1292 – 1562

Inhomogeneous heating of the material

TTLC / Short term load (1h)	[°C] 450 – 750 / [°F] 842 – 1382
TTLC / Continuous load (5000 h)	[°C] 400 – 560 / [°F] 752 – 1040

Acoustic characteristics

$$V_{\text{Long. [m/s]}} \mathbf{6300 - 6700}$$

Acoustic velocity
(ASTM C-1259)

The acoustic velocity value is valid for longitudinal propagation of acoustic waves and is a calculated value, using measurements according to the referred standard.

Chemical characteristics

Principal constituents (reference: DIN EN 1748-2-1)

The principal constituents of all the ceramic materials are as follows:

Component	Symbol	Percentage per mass
Silicon dioxide	SiO ₂	50 % – 80 %
Aluminium oxide	Al ₂ O ₃	15 % – 27 %
Lithium oxide	Li ₂ O	0 % – 5 %
Zinc oxide	ZnO	0 % – 5 %
Titanium oxide	TiO ₂	0 % – 5 %
Zirconium oxide	ZrO ₂	0 % – 5 %
Magnesium oxide	MgO	0 % – 8 %
Calcium oxide	CaO	0 % – 8 %
Barium oxide	BaO	0 % – 8 %
Sodium oxide	Na ₂ O	0 % – 2 %
Potassium oxide	K ₂ O	0 % – 2 %
Other (trace content on request)		0 % – 5 %

The materials do not contain any harmful substances according to the European directive 2002/95/EC "Hazardous Substances in electrical and electronically Equipment" and fulfill the terms of RoHS without any concerns.

End of life usage

Federal Republic of Germany waste disposal regulations differentiate five classes of waste, Z0 (non-restricted disposal), Z3 (household waste), and up to Z5 (highly toxic waste). All NEXTREMA® materials are classified as non-restricted disposal. Local government regulations may differ. Please contact the local authority if needed. NEXTREMA® must not be disposed of in recycling boxes for standard glass (e.g. glass bottles).

Chemical resistance

The chemical resistance of NEXTREMA® is more extensive than that of most other comparable materials.

Acid resistance (DIN 12116)	S	1 – 3
Alkaline resistance (ISO 695)	A	1 – 2
Hydrolytic class (DIN ISO 719)	HGB	1

Electrical characteristics

Specific electrical volume resistance (DIN 52326)

log $\rho_{(250\text{ °C})}$	$\Omega \cdot \text{cm}$	6.6 – 7.2
log $\rho_{(350\text{ °C})}$	$\Omega \cdot \text{cm}$	5.2 – 5.7
t_{K100}	°C	170 – 205

Specific electrical volume resistance at different temperatures (log ρ [$\Omega \cdot \text{cm}$])

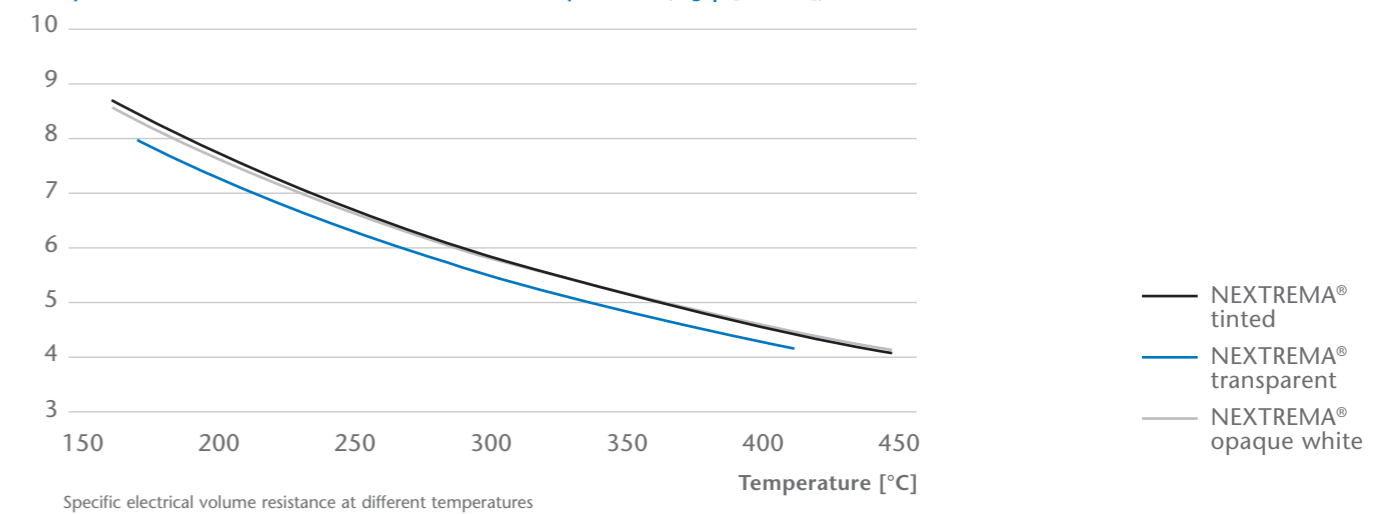

$$\epsilon_R (1 \text{ MHz}, 25 \text{ °C}) \quad 6.3 - 7.8$$

Dielectric constant
(DIN 53483)

$$\tan \delta (1 \text{ MHz}, 25 \text{ °C}) \quad 0.002 - 0.02$$

Dielectric loss tangent
(DIN 53483)

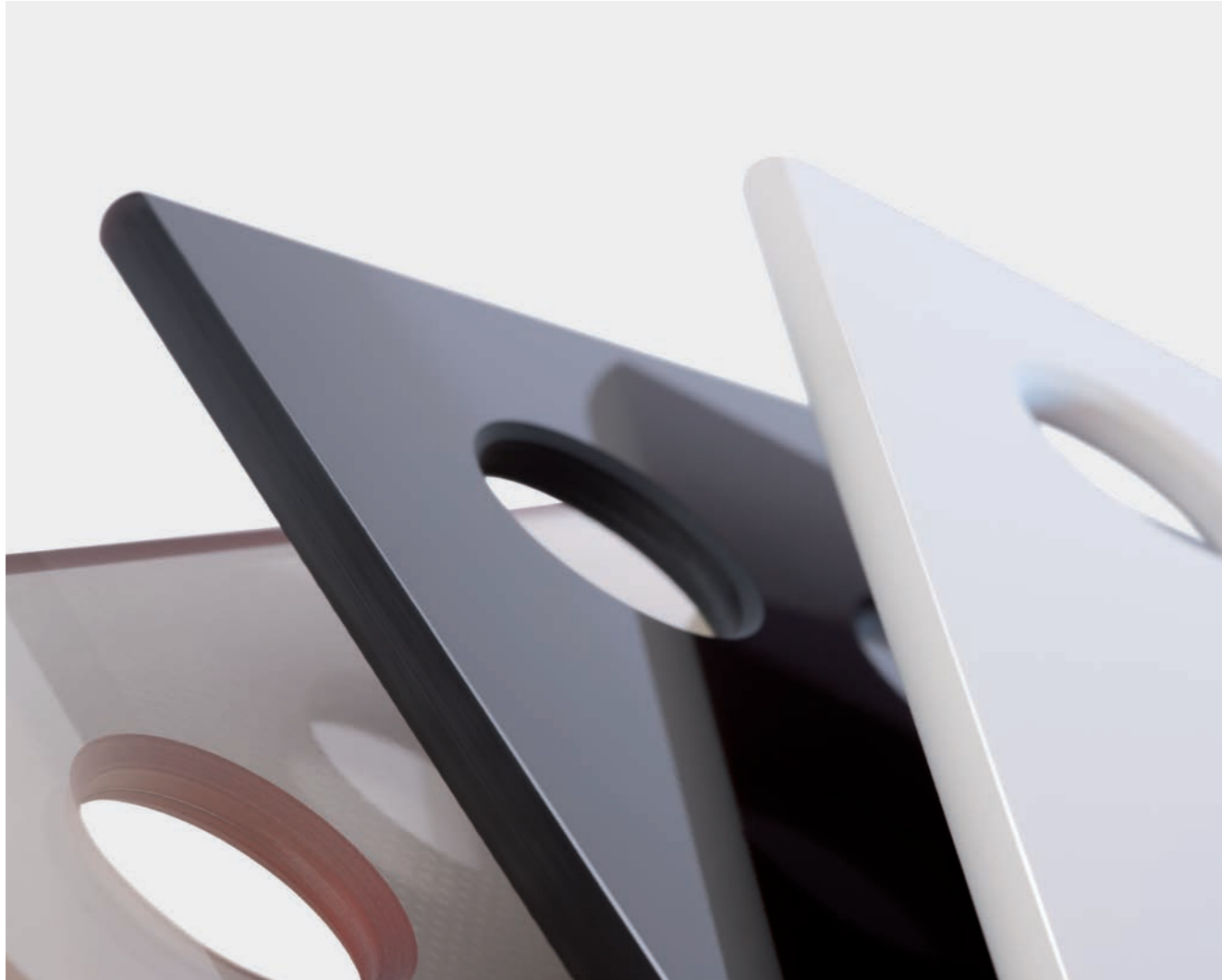

Your Notes:

NEXTREMA® is open for your ideas

Can you imagine NEXTREMA® being used in your company? Then get detailed information on the many possibilities on setting design and technology standards with NEXTREMA® in extreme conditions. Request the detailed NEXTREMA® data sheets.

Please see contact information on the back side.

We will gladly be of assistance.

Your Notes:

Home Tech

SCHOTT AG

Hattenbergstrasse 10

55122 Mainz

Germany

Phone +49 (0)6131/66-25431

Fax +49 (0)3641/28889162

info.nextrema@schott.com

www.schott.com/nextrema