

# SG01D-E18 (ERYCA\_custom) high precision UV-Index photodiode

## General Features



### Properties of the ERYCA\_custom photodiode

- DIN5050/ CIE087 UV-Index measurement with very small error  $\pm 3\%$
- TO18 hermetically sealed housing, 1 UVI ( $2,5 \mu\text{W}/\text{cm}^2$ )  $\approx 1,25 \text{ nA}$

### Information about the UV-Index (UVI)

The UV index is an international standard measurement of how strong the ultraviolet (UV) radiation from the sun is at a particular place on a particular day. It is a scale primarily used in daily forecasts aimed at the general public. The UV-Index is calculated by integrating the sun's UV spectrum multiplied with the Erythema action curve (fig. 1, black curve and fig. 2, formula 1). That integral is divided by  $25 \text{ mW}/\text{m}^2$  to generate a convenient index value, which becomes essentially a scale of 0 to 10. The Erythema action curve is a wavelength resolved measure of the sunburn danger. It is maximised at 297nm (UVB) and then strongly decreases towards UVA radiation. Literature: A. F. McKinlay and B. L. Diffey, "A reference action spectrum for ultraviolet induced erythema in human skin" CIE Journal, 6-1, 17-22 (1987)

### About the ERYCA sensors

The ERYCA is designed for accurate measurement of the UV-Index. ERYCA's error is  $<3\%$  only which is sufficiently small for scientific and high performance commercial applications. The ERYCA is available as:

**ERYCA\_custom** (SG01D-E18) photodiode,  $1,25\text{nA}/\text{UVI}$  ( $0,50\text{mm}^2$  SiC detector chip)

**ERYCA\_advanced** (SG01L-E5) cosine corrected photodiode,  $2\text{nA}/\text{UVI}$  ( $1,0\text{mm}^2$  SiC chip)

**ERYCA\_science** (SG01XL-E5) cosine corrected photodiode,  $8\text{nA}/\text{UVI}$  ( $4,0\text{mm}^2$  SiC chip)

**TOCON\_ERYCA** pre-amplified cosine corrected hermetically sealed low noise sensor with 5-15V power supply and approx.  $100\text{mV}/\text{UVI}$  voltage output (SiC detector chip)

### How ERYCA's $<3\%$ error is calculated?

A good erythema sensor's response needs to follow the Erythema Action curve (fig 1) as close as possible. Additionally the visible blindness needs to be extremely high as the visible part of sun's radiation exceeds the erythema causing radiation by five orders of magnitude. ERYCA works with a 4H SiC detector chip providing a visible blindness of more than ten orders of magnitude. That means that absolutely no visible light interferes the sensors output value. Sensors with a visible blindness of less than six orders of magnitude are unsuited for UVI measurement even if they match with the CIE curve. ERYCA's curve (fig. 1, red curve) has a near perfect match from 295nm to 320nm. From 320nm a leakage of approx. 0,1% is seen. To find out how that leakage negatively influences the UVI measurement a closer look at different sun spectra (varying tilt angle and ozone layer thickness) is needed. Fig. 4 shows different sun UV spectra issued by the Swiss governmental institute of meteorology. In total nine different sun spectra calculating an UVI from 1,12 to 10,92 were used. For error calculation the different sun spectra were integrated with the Erythema action curve and subsequently the integral of the same spectra with ERYCA's response curve (fig. 2, formula 1 and 2) were calculated. Finally the error was calculated by using formula 3 (fig. 2). As shown by the blue curve (fig. 3) the error of all UVI is less than 3%.

# SG01D-E18 (ERYCA\_custom) high precision UV-Index photodiode

**Fig. 1 Spectral Response**

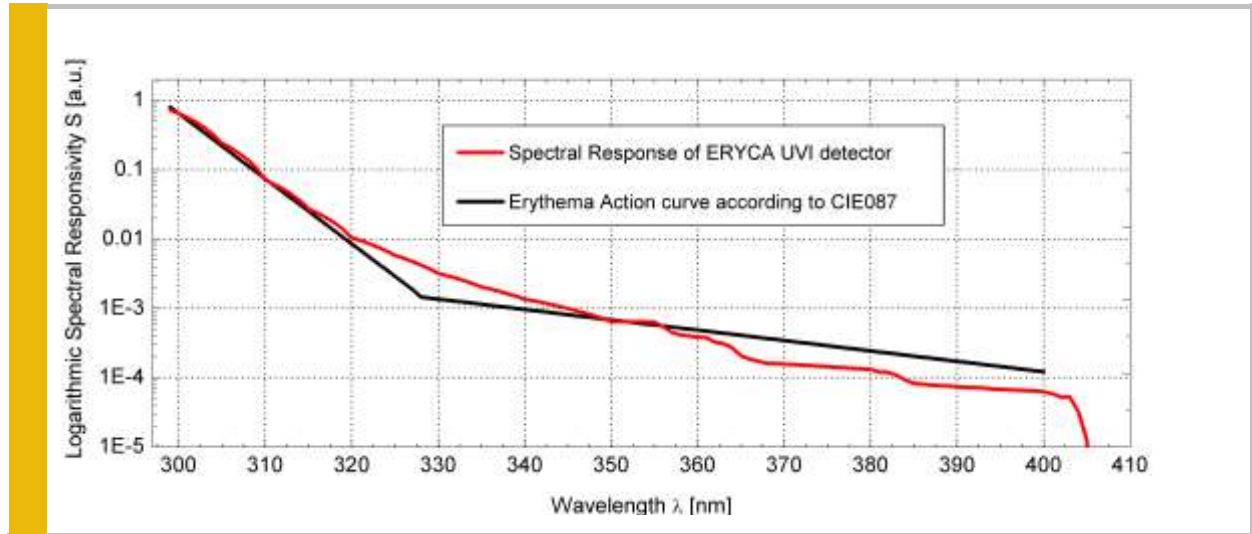

**Fig. 2 Calculation Formulae**

$$UVI_{ideal} = \int_{\lambda=297\text{ nm}}^{\lambda=400\text{ nm}} \frac{S(\lambda) \cdot CIE(\lambda)}{25\text{mW/m}^2} d\lambda \quad (1)$$

$$UVI_{real} = \int_{\lambda=297\text{ nm}}^{\lambda=400\text{ nm}} \frac{S(\lambda) \cdot ERYCA(\lambda)}{25\text{mW/m}^2} d\lambda \quad (2)$$

$$E = \frac{(UVI_{ideal} - UVI_{real}) \cdot 100}{UVI_{ideal}} \quad (3)$$

**Legend**  
 S(λ) = sun UV spectrum  
 CIE(λ) = CIE087 standard curve  
 ERYCA(λ) = ERYCA response curve  
 E = error in %

**Fig. 3 Error Graph**

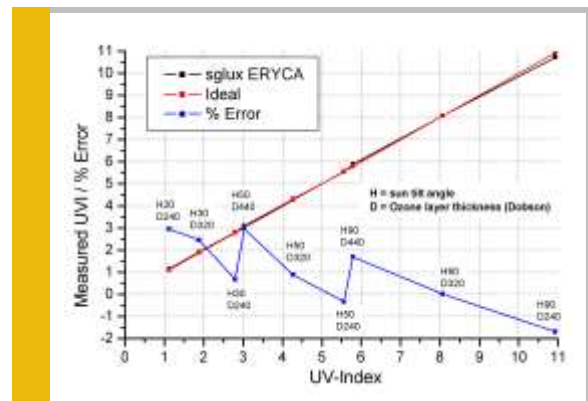

**Fig. 4 Sun Spectra Issued by the Swiss Meteo Institute**

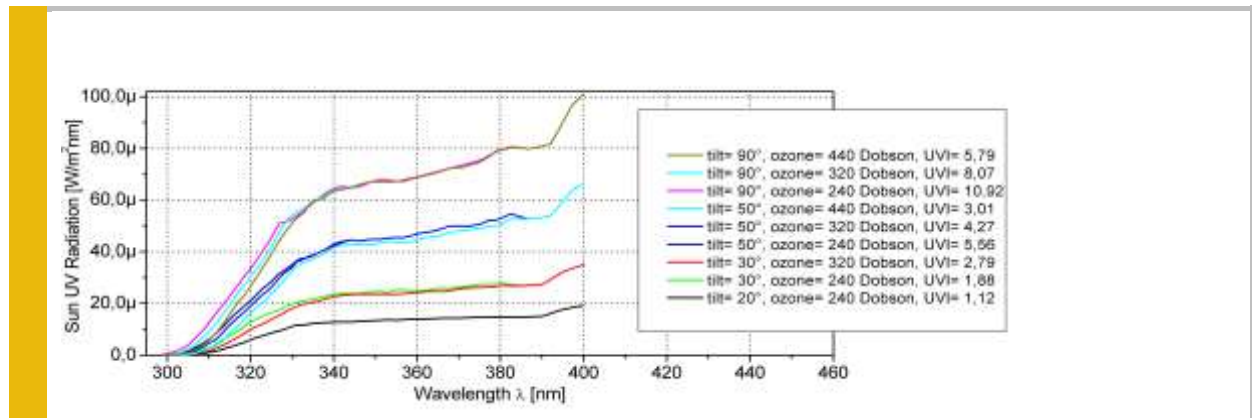

# SG01D-E18 (ERYCA\_custom)

## high precision UV-Index photodiode

### Specifications

Parameter	Symbol	Value	Unit
<b>Maximum Ratings</b>			
Operating Temperature Range	$T_{opt}$	-55 ... +170	°C
Storage Temperature Range	$T_{stor}$	-55 ... +170	°C
Soldering Temperature (3s)	$T_{sold}$	260	°C
Reverse voltage	$V_{Rmax}$	20	V
<b>General Characteristics (T=25°C)</b>			
Active Area	A	0,50	mm <sup>2</sup>
Dark current (1V reverse bias)	$I_d$	2,5	fA
Capacitance	C	188	pF
Short circuit (1 UVI)	$I_0$	1,25	nA
Temperature coefficient	$T_C$	<-0,1	%/K

### Circuit

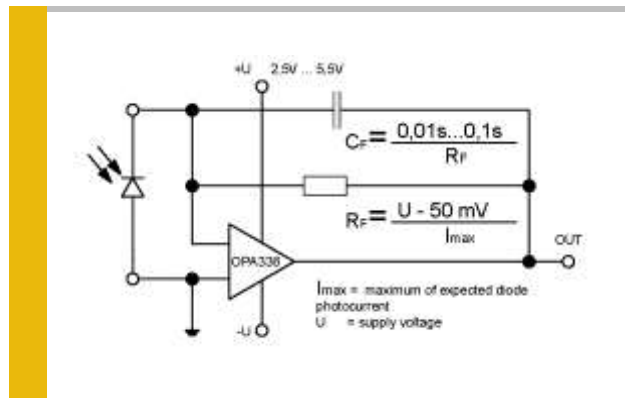

### Viewing Angle

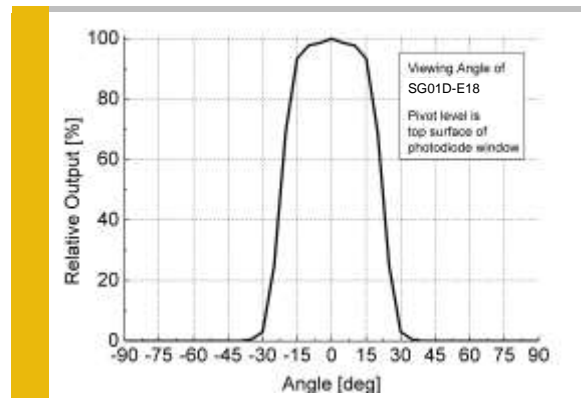

### Drawing

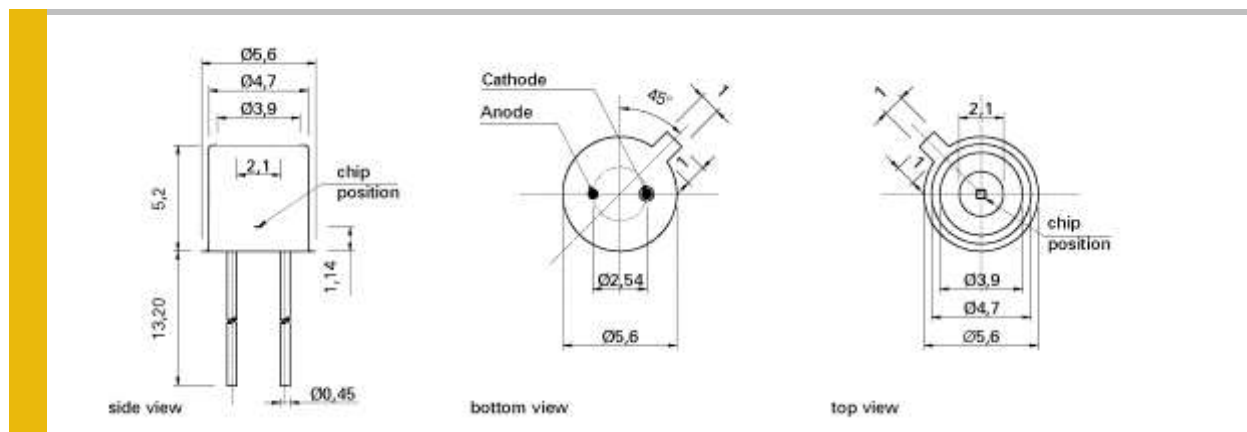

# SG01D-E18 (ERYCA\_custom)

## high precision UV-Index photodiode

### Application Note for Photodiodes

For correct reading of the photodiode the current (and NOT the voltage) must be analyzed. This requires a short circuiting of the photodiode. Usual approaches are using a **Picoamperemeter** or a **transimpedance amplifier** circuit.

To make the photodiode running reliably, in particular in harsh environment, EMC compatibility and protection against dust, water and mechanical influences is needed. Below listed modules base on a SiC photodiode and guarantee this protection and safety.

### TOCONs = UV Sensors with integrated amplifier



- SiC based UV hybrid detector with pre-amplifier (0-5V output), no additional amplifier needed, direct connection to controller, voltmeter, etc.
- Measures intensities from 1,8 pW/cm<sup>2</sup> up to 18 W/cm<sup>2</sup>
- UV broadband, UVA, UVB, UVC or Erythema measurements
- Upgrade to M12x1 housing with Hirschmann connector available

### Industrial UV probes



- Different housings e.g. with cosine response, water pressure proof or Sapphire windows
- Different electronic outputs configurable (voltage, current, USB, CAN, LAN)

### Laboratory Equipment & Calibration



The below listed products & services are helpful if you like to learn more about the UV radiation generated by your UV source:

- UV Radiometers for intensity check
- UV Dosimeters for dose control, e.g. curing applications
- UV Controllers to control lamps, valves etc.
- NIST and PTB traceable calibration for all UV sensors