

SANGAMO

Fit & forget...

Choice PR1n - 1 Channel Programmer

Installation Instructions



Pre-Installation Set Up

Before installing, set the bank of 4 DIP Switches on the back to configure the unit according to the chart below:

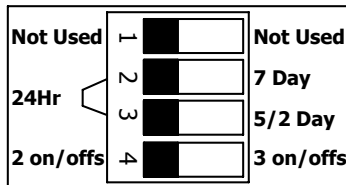

DIP Switches Shown in Factory Default Positions. (black = raised actuator of switch)

24 Hr Runs same programme every day.

5/2 Day Allows different on/off times at weekend.

7 Day Allows different on/off times every day.

Installation Safety Notes

This unit must be installed by a suitably qualified person in accordance with the latest IEE Wiring Regulations.

Isolate mains supply before commencing installation. Please read all installation instructions before proceeding.

Ensure that the fixed wiring connections to the mains supply is via a fuse rated at not more than 3 amps and a class 'A' switch having a contact separation of a minimum of 3mm in all poles. The recommended cable sizes are 1.0mm² or 1.5mm²

If the unit is fitted to a metal surface, **IT IS ESSENTIAL** that the metal be earthed. **DO NOT** use a surface mounting box.

No earth connection is required as the product is double insulated but ensure continuity of earth throughout the system.

Technical Data

Power Supply:	230V AC, 50Hz
Operating Temperature:	0°C to 40°C
Switch Rating:	230V AC, 2(1)A
Contact Type:	1B, Micro-Disconnection (Voltage Free)
Battery Type:	Lithium Cell CR2032
Enclosure Protection	IP30
Plastics	Thermoplastic, flame retardant
Insulation Class	Double
Wiring:	For fixed wiring only
Backplate	Industry standard
Dimensions:	140mm x 87mm x 37mm
Clock	12 hour am/pm, 1 minute resolution
Summer/Winter time change	Automatic
Clock Accuracy	+/- 1.5 sec/day
Program Cycle	24hr, 5/2day or 7day selectable.
Program On/off per day	2on/off, 3on/off selectable
Program Resolution	10mins
Program Selection	Auto, On all day, On constant, Off
Program Override	+1,2 or 3 Hr Boost & Advance to next program
Complies with	EN60730-1, EN60730-2.7, EMC Directive 2004/108/EC, LVD Directive 2006/95/EC

Fitting Back Plate – Direct Wall Mounting

1. Position the back-plate (terminals along top edge) with 100mm (min) clearance to its right, 25mm (min) above, 10mm (min) below and left. Ensure that the supporting surface will fully cover the back of the programmer.
2. The ideal location would be 1.4M above floor level, easily accessible, reasonably lit and free from condensation or temperature extremes.
3. Offer the back plate to the wall in the position where the programmer is to be mounted remembering that the back plate fits to the left hand side of the programmer. Mark the fixing positions through the slots in the backplate, drill and plug wall, then secure back plate in position using screws.
4. All necessary electrical connections should now be made. Ensure that the wiring to the back-plate terminals leads directly away from the terminals and is completely enclosed within the back-plate aperture. Wire ends must be stripped and screwed to the terminals so that minimal bare wire is showing.

Fitting Back Plate – Wiring Box Mounting

1. Fix the back-plate to a flush mounting single conduit box type UA1 (BS4662) using M3.5 x 14 screws. Take care to ensure the opening is adequate and will allow mounting of the unit onto the back-plate. The use of glue, mastic, or other sealants **MUST NOT**

2. All necessary electrical connections should now be made. Ensure that the wiring to the back-plate terminals leads directly away from the terminals and is completely enclosed within the back-plate aperture. Wire ends must be stripped and screwed to the terminals so that minimal bare wire is showing.

New Installations

Example circuit diagrams for typical installations are shown over. These diagrams are schematic and should be used as a guide only. Please ensure that all installations comply with the current IEE regulations.

For reasons of space and clarity not every system has been included and the diagrams have been simplified, for instance some Earth connections have been omitted.

Other control components shown in the diagrams i.e. Valves, Room Stats etc. are general representations only. However the wiring detail can be applied to the corresponding models of most manufacturers.

Continued Over...

New Installations

Cylinder and Room Thermostat Key:

C=Common Call = Call for heat or break on rise SAT = Satisfied on rise N= Neutral

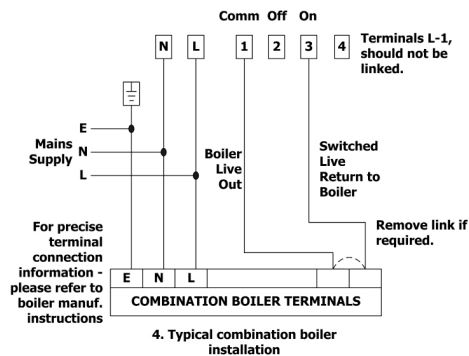
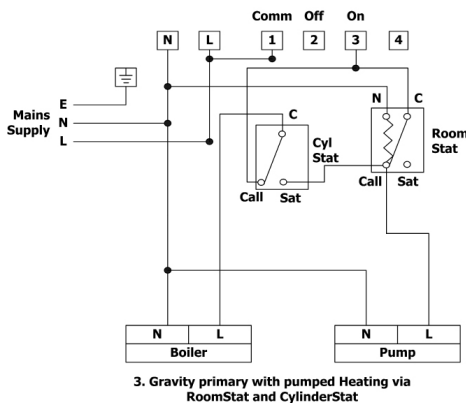
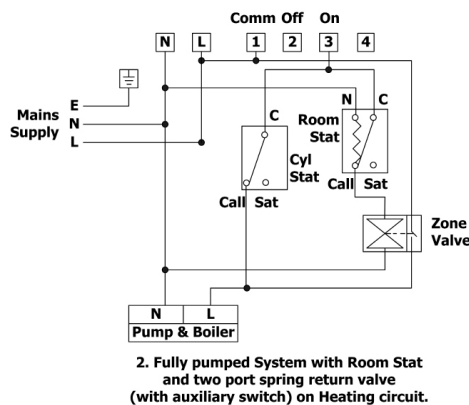
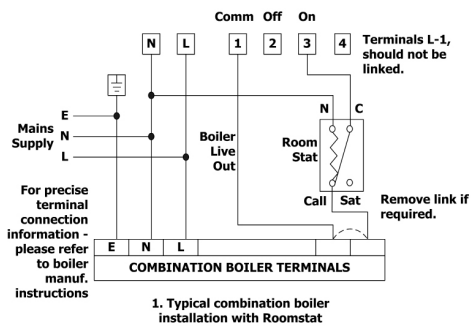

Existing Installations

1. Remove old programmer from its back plate mounting loosening any securing screws as dictated by its design.
2. Check compatibility of existing back plate & wiring arrangement with that of the new programmer. See online Programmer Compatibility Guide for direction.
3. Make all necessary changes to back plate & wiring arrangement to suit new programmer

Electrical Connections

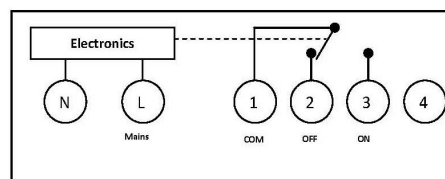

Note: The switch is volt free. Com should be linked to L for mains switching.

Fitting The Programmer

Loosen the two retaining screws on the bottom of the back plate.

Now fit the programmer to the back plate, ensuring the lugs of the back plate engage with the slots on the programmer.

Swing the bottom of the programmer into position ensuring the connection pins on the back of the unit locate into the terminal slots in the back plate.

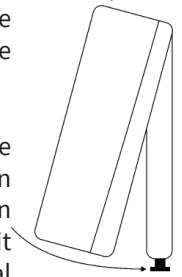

Tighten the two screws to fix the unit securely.

Commissioning

Switch on mains supply. Referring to the user guide:

1. Use the buttons to ensure correct product functionality.
2. Set timing and programme details in accordance with customer requirements.
3. Normally unit will be left with channel in 'Auto' mode.
4. Leave these installation instructions with customer for reference.

In the interests of continuous product improvement we reserve the right to alter designs, specifications and materials without prior notice and cannot accept liability for errors.

If you have a problem or require any further information please contact our technical team on:

01475 745131

Sangamo Limited
Industrial Estate, Port Glasgow,
Renfrewshire, PA14 5XG

Tel 01475 745131

Fax: 01475 744567

Email: enquiries@sangamo.co.uk

Web: www.sangamo.co.uk

SERVICE AND WARRANTY

Your product is not user serviceable. **PLEASE DO NOT TRY TO DISMANTLE THE UNIT.**

This product is guaranteed by your supplier for 5 years from the date of manufacture. If it should become defective please contact your installer or supplier for a replacement unit or visit www.sangamo.co.uk/returns

This product must meet Waste Electronic and Electrical Equipment Regulations (WEEE) for suitable environmental recycling, recovery and/or disposal. End of life products should be handled in line with local regulations. Alternatively return end of life product to Sangamo for correct disposal.

CUSTOMER CARE POLICY

As part of Sangamo's continuous improvement program, the company operates a Customer Care policy. This means we welcome your comments and complaints, as it can help us to improve our services to you, our customer.

Due to our policy of continuous product improvement and development, the specifications in this guide may be subject to change without prior notice.

