

SIEMENS



Industry Services

Testing windings by means of diagnostic measuring and test methods



Technology-based services for a greater competitive edge

Minimum downtime and the optimum use of staff and resources are key to sustainable success in industry. Siemens provides the basis for greater productivity, flexibility, and efficiency with technology-based services throughout the lifecycle of an industrial plant – reliably, globally, and around the clock. In-depth technology and product knowledge as well as industry expertise within Siemens' global network of experts ensure a considerable competitive edge.

The challenge:

Reliability that lasts for years

High voltage motors from Siemens have been in service reliably around the world for many years. They are used for a multitude of applications in virtually all industrial sectors. Special machines from Siemens such as are found for instance in rolling mills, ships and power plants are notable for their extremely high reliability and long life span.

As a high-quality technical product designed and built to individual requirements, each of the motors is of great if not central significance for operation of the plant as a whole. It is therefore important to ensure ongoing fault-free operation even after many years.

www.siemens.com/industry-services

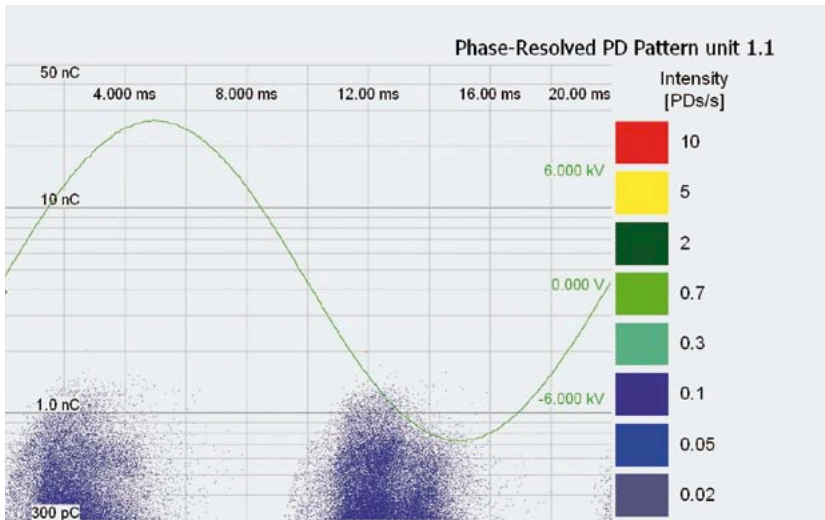

The solution:
Regular winding tests

Apart from regular servicing, qualified testing of motor windings play a major role in ensuring the availability of motors over the whole lifecycle of a plant.

It is now also possible to carry out winding tests and diagnostics of this kind locally using modern, portable measuring equipment and qualified analyses.

The advantage in the case of Siemens machines is that there are measured values available from production and quality assurance that were already recorded and archived during function testing before the machine was shipped. These data can be used as reference values for later analyses.

Siemens Industry Services supplies the following diagnostic measures:

1. Polarization index test

- The polarization index provides information regarding the level of humidity in the insulation or conductive dirt on the winding overhangs in the machine
 - Diagnosis of environmentally induced effects on the insulation characteristics
 - Implementation of measures based on these results

2. Measurement of the insulation resistance of the winding

- Measurement of the resistance of the winding insulation, phase-to-earth (housing, laminated core) or with respect to other phase conductors in the case of disconnected supply cables
- Magnitude of the insulation resistance as a measure of the insulating property of the winding insulation with respect to earth or between the winding elements
 - Diagnosis of humidity or condensation, conductive dirt that can cause a reduction in the permissible insulation resistance and damage in the insulation system

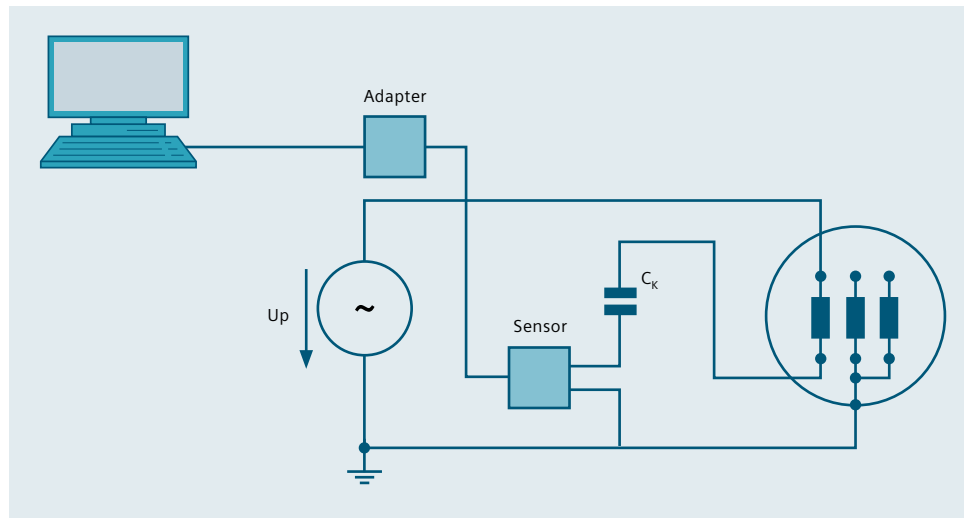

3. Dissipation factor test ($\tan \delta$)

- Dissipation factor as a measure of the total losses occurring in the insulation when an a.c. voltage is applied
 - Important enhancement of the partial discharge measurement
 - It is possible to draw conclusions about the condition of the winding insulation from the change (trend analysis)
 - It is possible to make a differentiation between the individual loss components

4. Diagnosing condition of winding insulation by means of partial discharge measurement (PD)

- Partial discharges inside the insulation or between insulation surfaces and earth potential
- Depending on position, discharge intensity and frequency they can cause ageing of the insulation and possibly also a shorter life
 - Local weak points can be identified using partial discharge diagnostics
 - Implementation of the measures resulting from the results

The benefit:

Reliable basis for decision making

- Early detection of operationally or environmentally induced weak points and impact on the winding
- Reduction in production downtimes and downtime costs through plannable measures
- Maximizing the life of electric machines
- Documentation with recommendation for measures to be taken
- Data archiving for reference measurements and trend analyses

The information in this data sheet contains general descriptions of the technical options and features available and may not always apply in individual cases or may be changed as a result of continuing product development. Performance features are binding only if expressly agreed upon by contract.

All product designations may be trademarks or product names of Siemens AG or supplier companies whose use by third parties for their own purposes could violate the rights of the owners.

**For further information and support,
please contact your local Siemens partner:**
www.siemens.com/services/partner

Siemens AG
Industry Sector
Customer Services Division
Lifecycle Services for Large Drives
Vogelweiherstr. 1–15
90441 Nuremberg
Germany

E-mail: ld-service.i-cs@siemens.com

Order No: E10001-T480-A247-V1-7600 |
Dispo No: 21638 | K No: 37500 |
Printed in Germany |
TH 241-120687 | DB | 08121.0
© Siemens AG 2012