

Power Schottky Rectifier - 3Amp 40~200Volt

Features

- For surface mounted applications
- Low profile package
- Built-in strain relief
- Metal silicon junction, majority carrier conduction
- Low power loss, high efficiency
- High current capability, low forward voltage drop
- High temperature soldering guaranteed
- High reliability
- High surge current capability
- Epitaxial construction
- Lead free device
- Halogen-Free

Mechanical data

- Case : Molded plastic
- Epoxy : UL 94V-0 rate flame retardant
- Terminals : Solder plated, solderable per MIL-STD-750,method 2026
- Polarity : Color band denotes cathode end
- Weight : 0.007 ounce 0.21 grams

Maximum ratings and Electrical characteristics

Parameters	SCR34	SCR36	SCR310	SCR315	SCR320	UNIT
Marking Code	SS34	SS36	S310	S315	S320	
Maximum Recurrent Peak Reverse Voltage	40	60	100	150	200	V
Maximum RMS Voltage	28	42	70	105	140	V
Maximum DC Blocking Voltage	40	60	100	150	200	V
Maximum Average Forward Rectified Current	3					A
Peak Forward Surge Current	80					A
Maximum Instantaneous Forward Voltage at 3A	Tc = 25°C	0.55	0.65	0.80	0.88	V
	Tc = 125°C	0.44	0.50	0.66	0.69	
Maximum Average Reverse Current at Rated DC Blocking Voltage	Tc = 25°C	0.5		0.05		mA
	Tc = 100°C	20		10		
Typical Junction Capacitance	150					pF
Typical Thermal Resistance R _{θJL} (Note 1)	17					°C/W
Operating and Storage Temperature Range	-50 to +125		-50 to +150			°C

Note : 1. Mounted on P.C.B with copper pad size 16mm x 16mm

September 2015 / Rev.7.1

SCR34 ~ SCR320

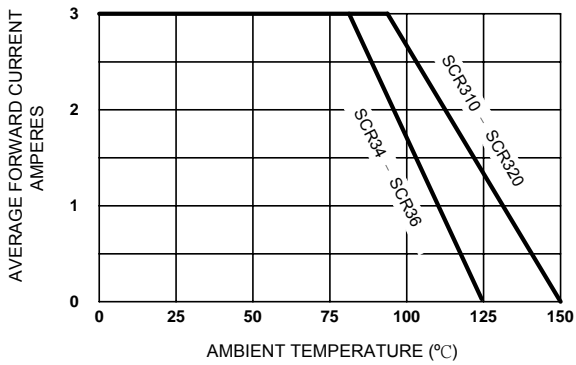

Figure 1. Forward Current Derating Curve

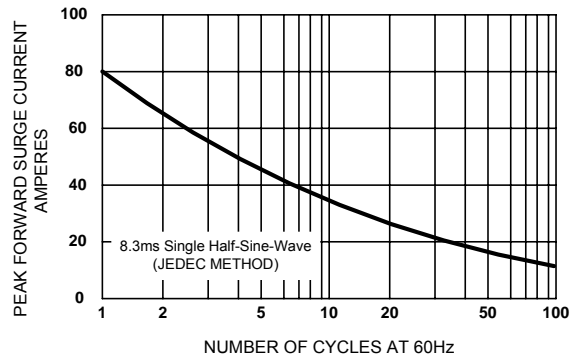

Figure 2. Maximum Non-repetitive Surge Current

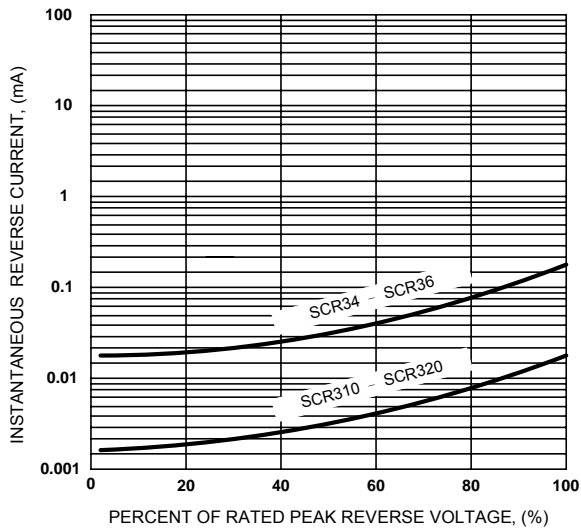

Figure 3. Typical Reverse Characteristics

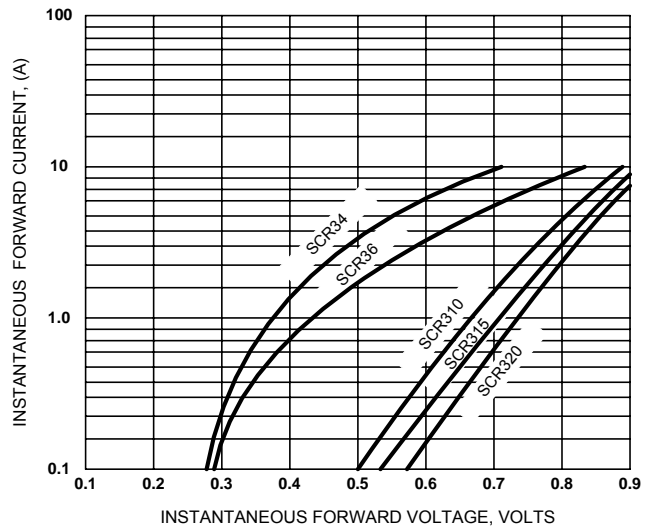

Figure 4. Typical Forward Characteristics

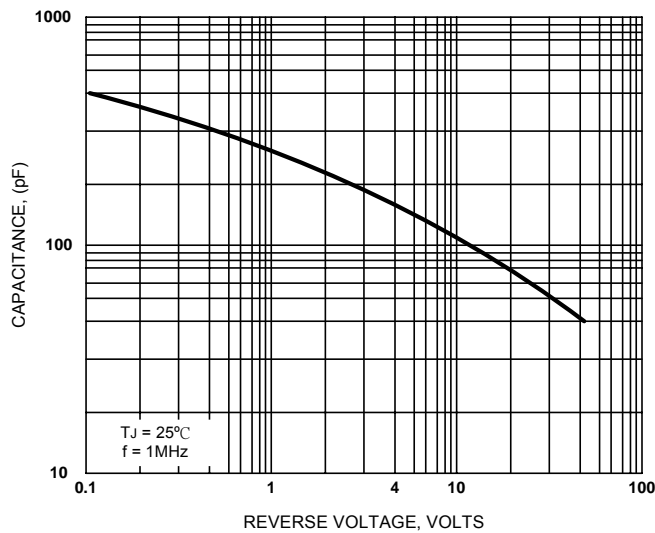

Figure 5. Typical Junction Capacitance



Sirectifier Semiconductor Inc.

U.S.A.: sgc@sirect.com

China: st@sirect.com

Taiwan: se@sirect.com

Hong Kong: hk@sirect.com

SCR34~SCR320

SMC - FW

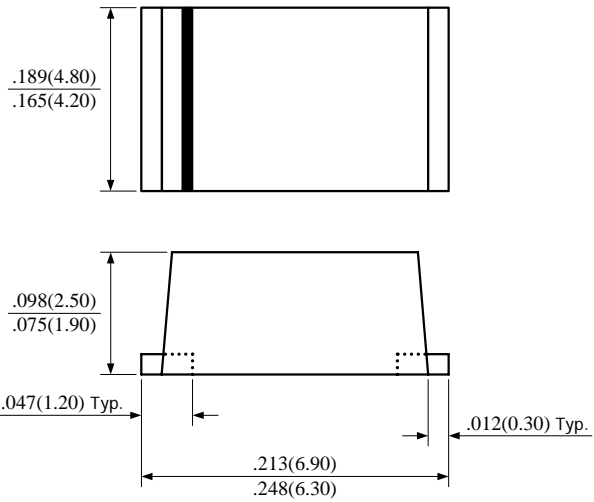

UNIT : inch(mm)

