

Stand Alone POTS Fiber Optic System

P31372 Station (Subscriber) Unit
P31379 Remote (Exchanger) Unit

Description & Installation

Table of Contents

	Page
1.0 SCOPE	2
2.0 PRODUCT OVERVIEW	2
2.1 Intended Uses	2
2.2 System Requirements	2
2.3 Physical Characteristics	2
3.0 PRODUCT FEATURES	3
3.1 High Voltage Isolation	3
3.2 Power Sources	4
4.0 INSTALLATION	4
4.1 Location and Mounting	4
4.2 Powering	4
4.3 Pair Connections	4
Table 2: Electrical Specifications	6

1.0 SCOPE

This document describes the technical specifications, technical requirements and installation instructions for the P31372 and P31379 SNC Lyte Lynx® Stand Alone POTS Fiber Optic System. It provides an understanding of the basic functions and features available with this product.

2.0 PRODUCT OVERVIEW

2.1 Intended Uses

SNC Lyte Lynx® fiber optic systems are intended for use at power substations, cell towers or similar locations where high voltage isolation is required on the incoming or outgoing copper telephone pairs to protect the telco network from harm and to provide a personnel safety barrier against voltages. This specifically includes protection from longitudinal voltage surges and Ground Potential Rise (GPR) that may occur during power system faults.

2.2 System Requirements

The fiber optic isolation system requires two units: the Remote unit (P31379) and the Station unit (P31372). The Remote or CO unit is also called the exchanger unit while the Station unit is also called the subscriber unit. The subscriber unit requires a 24VDC or 48VDC voltage source to operate. A duplex multi-mode fiber optic cable with ST/ST connectors is also required to link the two units.

2.3 Physical Characteristics

2.3.1 Mechanical Configuration

Both the Remote unit (P31379) and the Station unit (P31372) are made of a DAVAS eLYTE® card and a small weather proof enclosure.

2.3.2 Environmental Requirements

This Fiber Optic system is designed for an indoor or moderate outdoor environment and is operable in temperatures ranging from -10°C to 50°C (14°F to 122°F) under humidity conditions from 0-95% non-condensing.

2.3.3 Physical Dimensions

Table 1: Overall Physical Dimensions

Part Number	Height	Width	Depth
P31372	13.5" (34.29 cm)	9.5" (24.13 cm)	3.5" (8.89 cm)
P31379	8.25" (26.96 cm)	7.5" (19.05 cm)	3.31" (8.41 cm)

Figure 1: Photos of P31372 - POTS Station Unit



A: Top view with cover on

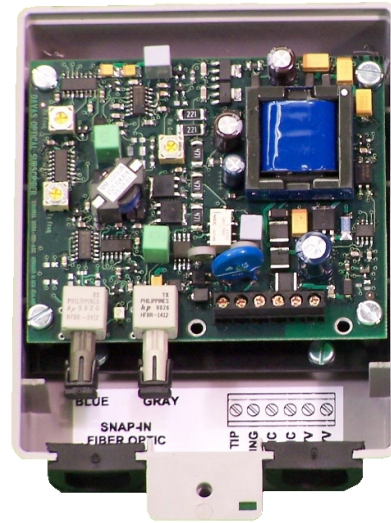

B: Top View With Cover Removed

Figure 2: Photos of P31379 - POTS Remote Unit



A. Top View With Cover On

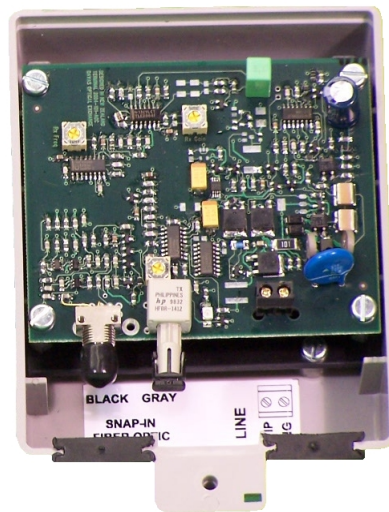

B: Top View With Cover Removed

3.0 PRODUCT FEATURES

3.1 High Voltage Isolation

The high voltage isolation depends on the separated distance of the exchanger and the subscriber unit. The further the two units are set apart, the higher the isolation voltage would be (100kV per 1 meter of separation). The maximum separation distance depends on the type of model and it's required fiber optic cable used.

3.2 Power Sources

The exchanger unit is line powered or is powered by the central office sealing current. The subscriber unit is locally powered or is powered by a 120VAC or 130VDC power source at the site.

4.0 INSTALLATION

4.1 Determining Location and Mounting

- 4.1.1 Determine the locations for each of the two units. The exchanger unit is to be placed outside of the zone of influence (300V point). The subscriber unit is to be placed inside the zone of influence.
- 4.1.2 Drill mounting holes as needed on the bottom of each unit. At least two mounting holes are recommended.
- 4.1.3 Position the unit against the wall or pole and center punch or mark the mounting holes. Drill pilot holes on the wall using appropriate size drill.
- 4.1.4 Mount the unit to the wall using appropriate screws or bolts (not included).

4.2 Powering

P31379 - POTS Remote (Exchanger) Unit

The exchanger unit is line powered. Power is provided by the sealing current or the 48V battery fed from the central office.

P31372 - POTS Station (Subscriber) Unit

The subscriber unit requires a 130VDC or 120VAC to operate.

130VDC Input

If available voltage source at site is 130VDC, connect the 130VDC to black and white leads on left hand side, negative (-) terminal goes to white lead and positive terminal goes to black lead.

120VAC Input

If available voltage source at site is 120VAC, connect the line (black or brown) wire to black lead and connect neutral (white or blue) wire to the white lead on left hand side inside unit.

Pair connections

Fiber Optic Connections

A pair of multi-mode fiber optic cables with ST - ST connectors should be used. Poke two holes in one of the grommets on the bottom of the unit and run the fiber optic cables in through these holes. If there is any extra length of fiber optic cables hanging loose, wind them around inside the unit and tie them down with cable ties. Connect the fiber optic cables to the fiber optic connectors located at the bottom of the card. See Figure 3 Block Diagram for proper connections.

Figure 3: Fiber Optic Connection Block Diagram

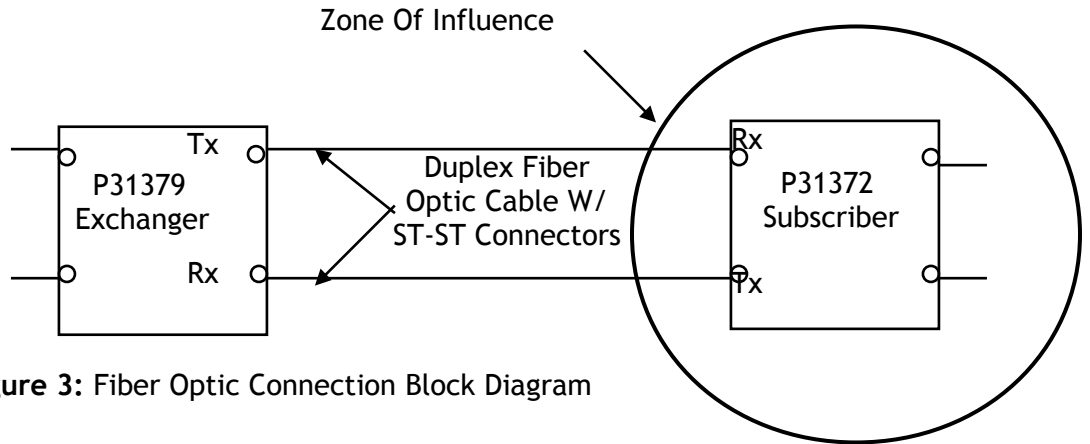

Figure 3: Fiber Optic Connection Block Diagram

Copper Pair Connections

Poke a hole in one of the grommets on the bottom of the unit and run the metallic wire pair in through the hole from outside. Connect the wire pair to the connector block located at the bottom of the card. Using a small Phillips screwdriver, connect one of the wires to terminal marked "TIP" and the other to terminal marked "RING". See Figure 4 Block Diagram for proper connections.

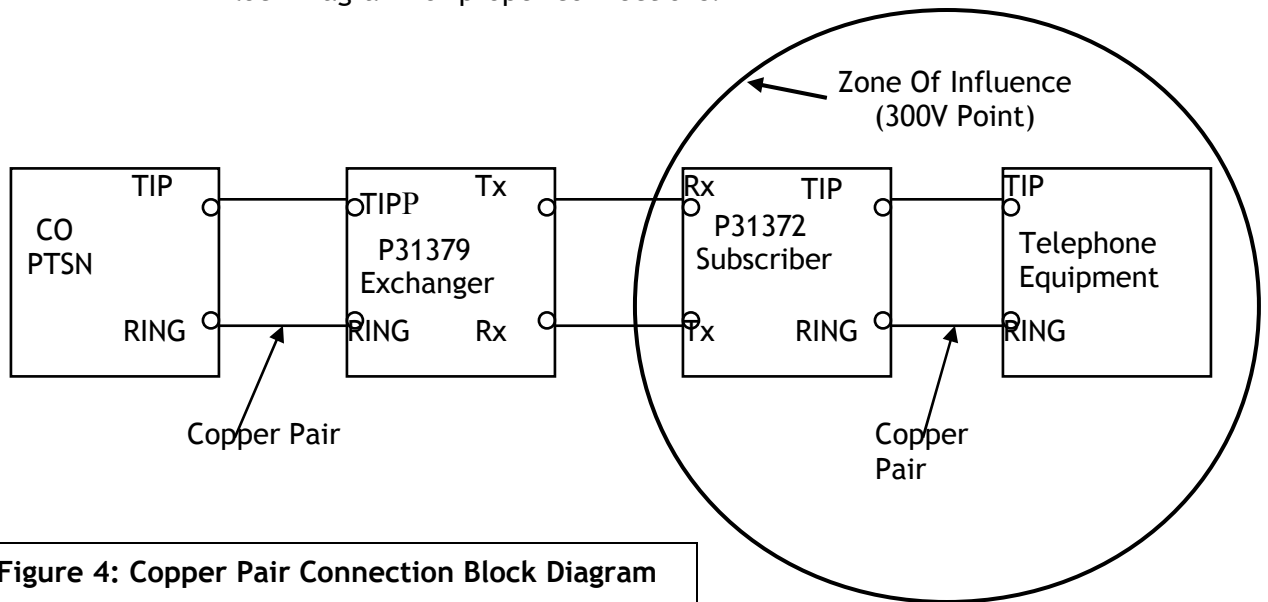

Figure 4: Copper Pair Connection Block Diagram

TABLE 2: ELECTRICAL SPECIFICATIONS

Optical Transceiver	Multi-Mode
Electrical Isolation	100kV per meter
Maximum Fiber Optic Length	2.7 km (8,800 ft)
Transmit Modulation	Frequency Modulation Carrier Frequency = 125kHz Nominal Ringing Is By Pulsed DC
Frequency Response	300 Hz - 3025 Hz (+/-0.9 dB)
Time Delay	200 μ S
Insertion Loss @ 2kHz	+/- 0.25 dB
Return Loss (600 Ω Impedance)	-18 dB (300 - 3400 Hz)
Overload Level	+ 3.5 dBm @ 1 KHz
Harmonic Distortion	1% (<0 dB)
Noise Ration	<-65dBnc
Input Impedance (Copper)	600 Ω
Signaling Type	DTMF
Ringing Signals	60 Vrms, Sine Wave, 16.6, 20, 25 & 30 Hz
Maximum Loop Resistance	3000 Ω
Power Consumptions	20 μ A (On hook) 10 mA (Off hook)

For further information or for technical support - call 800-558-3325
or visit www.sncmfg.com



SNC Manufacturing Co., Inc.

101 West Waukau Ave., Oshkosh, WI 54902-7299
800-558-3325 or 920-231-7370 FAX 920-231-1090

E-mail: telecom@sncmfg.com

Website: www.sncmfg.co

