

**SNC Manufacturing Co., Inc.**



**Glitch Tamer**

**P31066 – Glitch Tamer Six**

**P31069 – Glitch Tamer Igniter**

# Glitch Tamer Six

## Application Notes

**Glitch Tamer Six - P31066**  
UL Listing 100902



The Glitch Tamer has two six-pair cables. One connects toward the central office and the other toward the field or customer end. Either cable can be in or out. However, all pairs must run through the Glitch Tamer in the same direction.

The Glitch Tamer Six functions as a “mini-INT” (Induction Neutralizing Transformer), which means one of the pairs going through the Glitch Tamer must be grounded at the central office and at the station end of the circuit to provide a primary winding or “exciting” pair. This provides the necessary exciting current path to make the Glitch Tamer perform effectively.

If a spare (unused) pair is not available for excitation, a Glitch Tamer Igniter, TEN, Super Ten or HDR will allow a working pair to provide the excitation. The result is that a spare pair is no longer required to be grounded at each end of a neutralized cable route.

### Excitation

Excitation for the Glitch Tamer Six should be determined by the type of problem encountered:

- \* If the problem is operational and caused by excess of 60Hz induction, the Glitch Tamer should be excited using a Transformer Exciting Network (TEN - P15688) or Glitch Tamer Igniter.
- \* If the problem is excessive noise, the Glitch Tamer Six should be excited using a Harmonic Drainage Reactor (HDR - P15168.)
- \* If the problem is both 60Hz and noise, a Super-TEN (P15176) should be used for excitation. The Super -TEN combines the performance of a TEN and an HDR.



**Glitch Tamer Igniter - P31069**  
UL Listing 100902

The excitation units are bridged to the tip and ring conductors of a working pair in the cable which serves the equipment to be protected. A ground must also be connected to the TEN, HDR, Igniter or Super-TEN. For additional information on the use of TENs, Super-TENs and HDRs, refer to the application notes for those products.

# Glitch Tamer Instruction Schematic

No polarity concern.  
Cut into cable pairs  
to be mitigated of  
voltage interference.

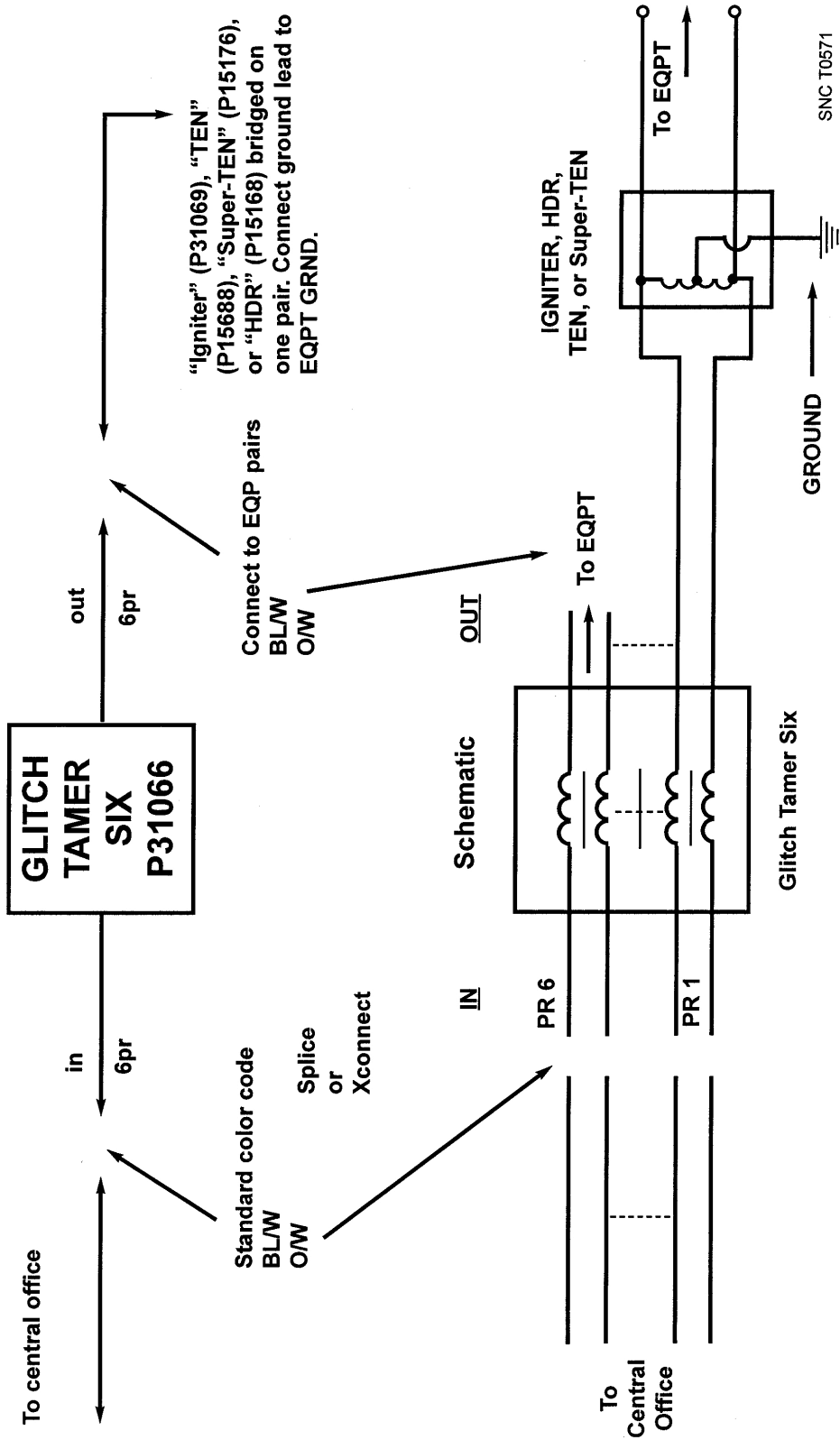

SNC T0571

For further information or for technical support - call 800-558-3325  
or visit [www.sncmfg.com](http://www.sncmfg.com)



**SNC Manufacturing Co., Inc.**

101 West Waukau Ave., Oshkosh, WI 54902-7299  
800-558-3325 or 920-231-7370 FAX 920-231-1090  
E-mail: [telecom@sncmfg.com](mailto:telecom@sncmfg.com)  
Website: [www.sncmfg.com](http://www.sncmfg.com)