

STI Extinguisher Stopper®



STI-6200

PRODUCT OVERVIEW

Fed up with replacing and recharging your fire extinguisher? This sturdy, tamperproof, self-contained device is the answer. It has proven highly effective in helping prevent theft, misuse and vandalism of fire extinguishers. Extinguisher Stopper will leave the extinguisher accessible for emergencies and will not interfere in the event of a real fire.

HOW IT WORKS

Its highly visible 'STOP' sign discourages wrongful use. If the protected fire extinguisher is moved from its normal position an integral sounder emits a piercing 95/105 dB alarm. The device is easy to install and a deactivation cable is supplied for ease of servicing the extinguisher. It comes complete with an operating cable kit and a 9V PP3 alkaline battery.

KEY FEATURES

General Information

- It has proved highly effective in helping prevent theft, misuse or vandalism of fire extinguishers.
- Does not interfere with use of protected firefighting equipment.
- Three year guarantee against breakage of the polycarbonate housing (one year on electromechanical and electronic components).

Design

- Compact design (136mm diameter x 50mm deep) mounts easily next to the extinguisher.

Construction

- Virtually indestructible polycarbonate housing.
- Polycarbonate is UV-stabilized.
- Self-contained device, tamperproof and sturdy.

Installation

- Easy to install.
- Deactivation cable is supplied for ease of servicing the extinguisher.
- Supplied complete with an operating cable kit, allowing the connection around the neck of the extinguisher.

Electronics

- Powered by a 9V PP3 alkaline battery (included).
- Sounds powerful 95/105 dB (at 1 metre) warning alarm when activated.

Options

- Option of coming with a built in wireless device, used in conjunction with the 8-Channel Receiver.
- Deactivation cable is provided for service by authorised personnel.

Remote Wireless Monitoring of Fire Extinguishers

- You can now be alerted to any vandalism or authorised use of a fire extinguishers in the event of an emergency. Upon activation, the Extinguisher Stopper (when fitted with an optional transmitter and sounder) will emit a localised alarm as well as triggering the 4-Channel (STI-34104) or 8-Channel Receiver (STI-34108), providing a visual and audible indication, remotely.



For more information, call +44 (0)1527 520 999 or visit www.sti-emea.com



**Safety Technology
International**

STI Extinguisher Stopper®

Dimensions and Technical Information

SPECIFICATIONS

MODELS AVAILABLE

- STI-6200** Extinguisher Stopper (includes operating cable kit)
- STI-6200WIR** Wireless Extinguisher Stopper
- STI-6200WIR4** Wireless Extinguisher Stopper with 4-Channel Receiver
- STI-6200WIR8** Wireless Extinguisher Stopper with 8-Channel Receiver

Accessories:

- STI-6204** Service/deactivation cable
- STI-6205** Operating cable kit (includes operating cable and seal)
- STI-6206** Seal
- F021** Tamper key

NB:

The STI-6200 comes complete with everything needed for a single extinguisher installation

Housing	3mm polycarbonate
Dimensions	136mm H x 136mm W x 50mm D
Power Source	9 VDC Alkaline
Sounder Output (at 1 metre)	95 dB - low/ 105 dB - high
Operating Cable	3mm galvanised steel
Standby Current	None
Alarm Current	40 mA at 95 dB / 150 mA at 105 dB

* 12 VDC and 24 VDC models are available

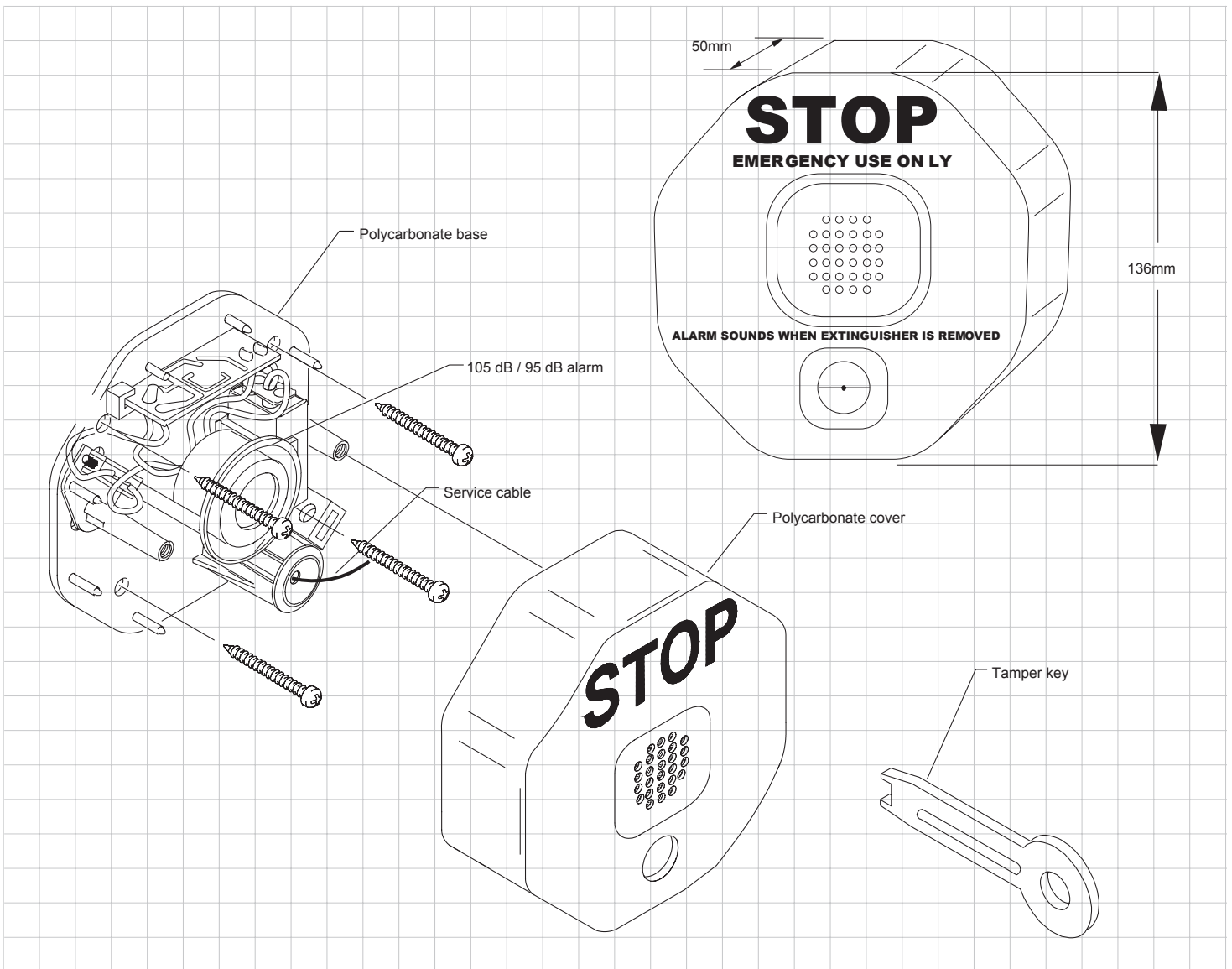

Safety Technology International

UK Office
 Taylor House
 34 Sherwood Road
 Bromsgrove
 Worcestershire
 B60 3DR, England

Tel: +44 (0)1527 520 999
 Fax: +44 (0)1527 501 999
 info@sti-emea.com
 www.sti-emea.com

USA Head Office
 2306 Airport Road
 Waterford, Michigan
 48327 - 1209

Tel: +248-673-9898
 Fax: +248-673-1246
 Toll-free: 0800-888-4STI
 info@sti-usa.com
 www.sti-usa.com