

XFP-10G-L-OC192-SR1-TP

10Gb/s 10km Datacom XFP Optical Transceiver

PRODUCT FEATURES

- Hot-pluggable XFP footprint
- Supports 9.95Gb/s to 10.7Gb/s bit rates
- Power dissipation <2.0W
- temperature range: -5°C to 70°C
- RoHS-6 Compliant (lead-free)
- Single power supply: 3.3V
- Maximum link length of 10km
- Uncooled 1310nm DFB laser
- Full Duplex LC connector
- No Reference Clock required
- Built-in digital diagnostic functions
- Standard bail release mechanism

APPLICATIONS

- 10GBASE-LR/LW 10G Ethernet
- 10G Fibre Channel
- SONET OC-192 SR-1 SDH STM I-64.1

XFP-10G-L-OC192-SR1-TP Small Form Factor 10Gb/s (XFP) transceivers are compliant with the current XFP Multi-Source Agreement (MSA) Specification¹. They comply with 10-Gigabit Ethernet 10GBASE-LR/LW per IEEE 802.3ae and 10G Fibre Channel. Digital diagnostics functions are available via a 2-wire serial interface, as specified in the XFP MSA³. The transceiver is RoHS compliant and lead free per Directive 2002/95/EC³

PRODUCT SELECTION

I. Pin Descriptions

| Pin | Logic | Symbol | Name/Description | Ref. |
|-----|---------|-----------|--|------|
| 1 | | GND | Module Ground | 1 |
| 2 | | VEE5 | Optional -5.2 Power Supply – Not required | |
| 3 | LVTTL-I | Mod-Desel | Module De-select; When held low allows the module to respond to 2-wire serial interface commands | |
| 4 | LVTTL-O | Interrupt | Interrupt (bar); Indicates presence of an important condition which can be read over the serial 2-wire interface | 2 |
| 5 | LVTTL-I | TX_DIS | Transmitter Disable; Transmitter laser source turned off | |
| 6 | | VCC5 | +5 Power Supply – Not required | |
| 7 | | GND | Module Ground | 1 |

| | | | | |
|----|-----------|------------|--|---|
| 8 | | VCC3 | +3.3V Power Supply | |
| 9 | | VCC3 | +3.3V Power Supply | |
| 10 | LVTTL-I | SCL | Serial 2-wire interface clock | |
| 11 | LVTTL-I/O | SDA | Serial 2-wire interface data line | 2 |
| 12 | LVTTL-O | Mod_Abs | Module Absent; Indicates module is not present. Grounded in the module. | 2 |
| 13 | LVTTL-O | Mod_NR | Module Not Ready; 's defines it as a logical OR between RX_LOS and Loss of Lock in TX/RX. | 2 |
| 14 | LVTTL-O | RX_LOS | Receiver Loss of Signal indicator | 2 |
| 15 | | GND | Module Ground | 1 |
| 16 | | GND | Module Ground | 1 |
| 17 | CML-O | RD- | Receiver inverted data output | |
| 18 | CML-O | RD+ | Receiver non-inverted data output | |
| 19 | | GND | Module Ground | 1 |
| 20 | | VCC2 | +1.8V Power Supply – Not required | |
| 21 | LVTTL-I | P_Down/RST | Power Down; When high, places the module in the low power stand-by mode and on the falling edge of P_Down initiates a module reset | |
| | | | Reset; The falling edge initiates a complete reset of the module including the 2-wire serial interface, equivalent to a power cycle. | |
| 22 | | VCC2 | +1.8V Power Supply – Not required | |
| 23 | | GND | Module Ground | 1 |
| 24 | PECL-I | RefCLK+ | Reference Clock non-inverted input, AC coupled on the host board – Not required | 3 |
| 25 | PECL-I | RefCLK- | Reference Clock inverted input, AC coupled on the host board – Not required | 3 |
| 26 | | GND | Module Ground | 1 |
| 27 | | GND | Module Ground | 1 |
| 28 | CML-I | TD- | Transmitter inverted data input | |
| 29 | CML-I | TD+ | Transmitter non-inverted data input | |
| 30 | | GND | Module Ground | 1 |

Notes:

1. Module circuit ground is isolated from module chassis ground within the module.
2. Open collector; should be pulled up with 4.7kΩ – 10kΩ on host board to a voltage between 3.15V and 3.6V.
3. A Reference Clock input is not required by the XFP-10G-L-OC192-SR1-TP. If present, it will be ignored.

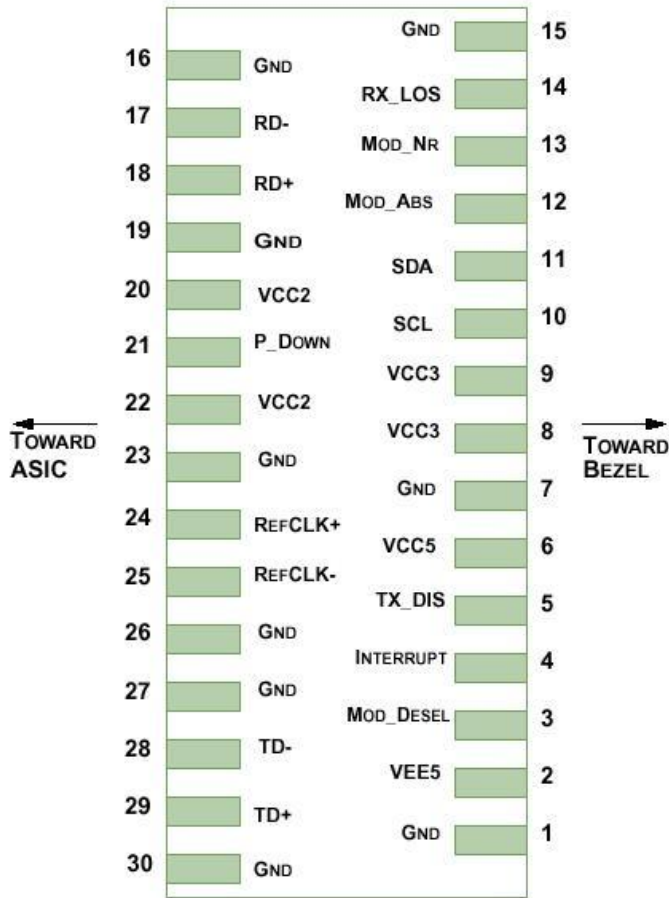

Diagram of Host Board Connector Block Pin Numbers and Name

III. Absolute Maximum Ratings

| Parameter | Symbol | Min | Typ | Max | Unit |
|----------------------------|-----------------|------|-----|-----|------|
| Maximum Supply Voltage | Vcc3 | -0.5 | | 4.0 | V |
| Storage Temperature | T _S | -40 | | 85 | °C |
| Case Operating Temperature | T _{OP} | -5 | | 70 | °C |

IV. Electrical Characteristics (T_{OP} = -5 to 70 °C, V_{CC3} = 3.13 to 3.45 Volts)

| Parameter | Symbol | Min | Typ | Max | Unit | Ref. |
|--------------------------------|---------------------|------|-----|----------|------|------|
| Supply Voltage #2 | Vcc3 | 3.13 | | 3.45 | V | |
| Supply Current – Vcc3 supply | Icc3 | | | 450 | mA | |
| Module total power | P | | | 2.0 | W | 1 |
| Transmitter | | | | | | |
| Input differential impedance | R _{in} | | 100 | | Ω | 2 |
| Differential data input swing | V _{in,pp} | 120 | | 820 | mV | |
| Transmit Disable Voltage | V _D | 2.0 | | Vcc | V | 3 |
| Transmit Enable Voltage | V _{EN} | GND | | GND+ 0.8 | V | |
| Transmit Disable Assert Time | | | | 10 | us | |
| Receiver | | | | | | |
| Differential data output swing | V _{out,pp} | 340 | 650 | 850 | mV | 4 |

| | | | | | | |
|------------------------|------------------|----------------|--|--------------|----|---|
| Data output rise time | t_r | | | 38 | ps | 5 |
| Data output fall time | t_f | | | 38 | ps | 5 |
| LOS Fault | $V_{LOS\ fault}$ | $V_{CC} - 0.5$ | | V_{CCHOST} | V | 6 |
| LOS Normal | $V_{LOS\ norm}$ | GND | | GND+0.5 | V | 6 |
| Power Supply Rejection | PSR | | | | | 7 |

Notes:

1. Maximum total power value is specified across the full temperature and voltage range.
2. After internal AC coupling.
3. Or open circuit.
4. Into 100 ohms differential termination.
5. 20 – 80 %
6. Loss Of Signal is open collector to be pulled up with a 4.7k – 10kohm resistor to 3.15 – 3.6V. Logic 0 indicates normal operation; logic 1 indicates no signal detected.
7. Per Section 2.7.1. in the XFP MSA Specification .

V. Optical Characteristics ($T_{OP} = -5$ to 70 °C, $V_{CC3} = 3.13$ to 3.45 Volts)

| Transmitter | | | | | | |
|---|-------------|----------|------|------|--------------------------|---|
| Average Optical Power | P_f | -6 | | -1 | dBm | |
| Optical Wavelength | λ | 1290 | 1310 | 1330 | nm | |
| Spectral Width (-20dB) | DL | | | 0.35 | nm | |
| Sidemode Suppression ratio | SSR_{min} | 30 | | | dB | |
| Optical Extinction Ratio | ER | 3.5 | 6 | | dB | |
| Transmitter and Dispersion Penalty | TDP | | | 2 | dB | |
| Average Launch power of OFF transmitter | P_{OFF} | | | -30 | dBm | |
| Tx Jitter | | T_{xj} | | | Per 802.3ae requirements | |
| Relative Intensity Noise | RIN | | | -130 | dB/Hz | |
| Receiver | | | | | | |
| Receiver Sensitivity | R_{SENS} | | | -15 | dBm | 1 |
| Maximum Input Power | P_{MAX} | 0.5 | | | dBm | |
| Optical Center Wavelength | λ_C | 1260 | | 1600 | nm | |
| Receiver Reflectance | R_{rx} | | | -14 | dB | |
| LOS De-Assert | LOS_D | | | -18 | dBm | |
| LOS Assert | LOS_A | -32 | | | dBm | |
| LOS Hysteresis | | 0.5 | | | dB | |

Notes:

1. Measured with worst ER; $BER < 10^{-12}$; $2^{31} - 1$ PRBS.

VI. General Specifications

| Parameter | Symbol | Min | Typ | Max | Units |
|----------------------------|-----------|------|-----|------------|-------|
| Bit Rate | BR | 9.95 | | 10.7 | Gb/s |
| Bit Error Ratio | BER | | | 10^{-12} | |
| Max. Supported Link Length | L_{MAX} | | 10 | | km |

Notes:

1. 10GBASE-LR/LW,
2. Tested with a $2^{31} - 1$ PRBS

VII. Environmental Specifications

XFP-10G-L-OC192-SR1-TP transceivers have a commercial operating case temperature range of -5°C to +75°C.

| Parameter | Symbol | Min | Typ | Max | Units |
|----------------------------|------------------|-----|-----|-----|-------|
| Case Operating Temperature | T _{op} | -5 | | 75 | °C |
| Storage Temperature | T _{sto} | -40 | | 85 | °C |

Relative Humidity 5 - 85 %

Class 1 Laser Product EN 60825-1 Compliance

VIII. Digital Diagnostic Functions

As defined by the XFP MSA¹, XFP transceivers provide digital diagnostic functions via a 2-wire serial interface, which allows real-time access to the following operating parameters:

- Transceiver temperature
- Laser bias current
- Transmitted optical power
- Received optical power
- Transceiver supply voltage

It also provides a sophisticated system of alarm and warning flags, which may be used to alert end-users when particular operating parameters are outside of a factory-set normal range.

The operating and diagnostics information is monitored and reported by a Digital Diagnostics Transceiver Controller (DDTC) inside the transceiver, which is accessed through the 2-wire serial interface. When the serial protocol is activated, the serial clock signal (SCL pin) is generated by the host. The positive edge clocks data into the XFP transceiver into those segments of its memory map that are not write-protected. The negative edge clocks data from the XFP transceiver. The serial data signal (SDA pin) is bi-directional for serial data transfer. The host uses SDA in conjunction with SCL to mark the start and end of serial protocol activation. The memories are organized as a series of 8-bit data words that can be addressed individually or sequentially. The 2-wire serial interface provides sequential or random access to the 8 bit parameters, addressed from 000h to the maximum address of the memory.

IX. Mechanical Specifications

The transceivers are compliant with the dimensions defined by the XFP Multi-Sourcing Agreement (MSA).

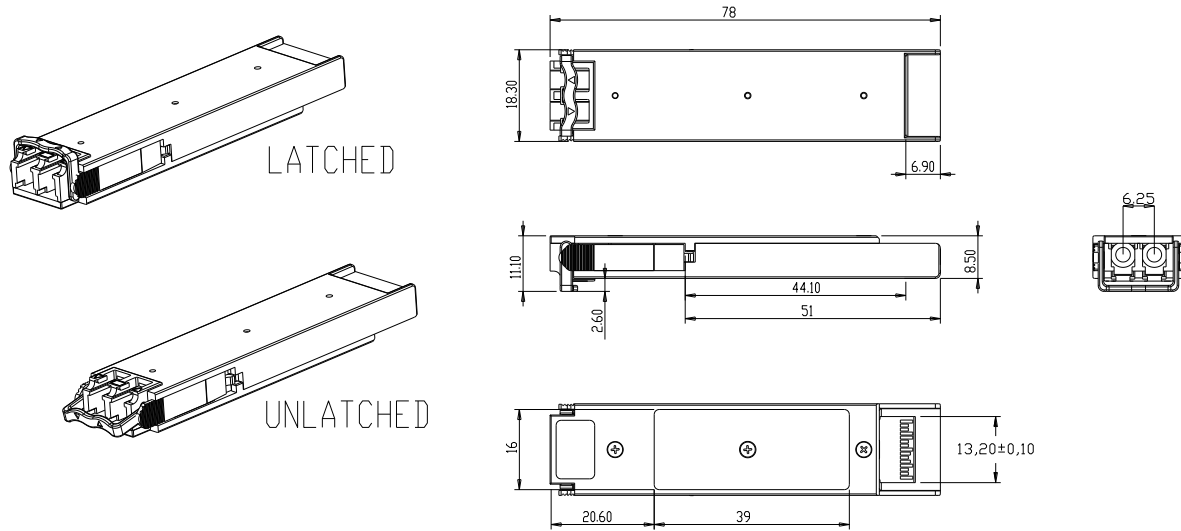

XFP Transceiver (dimensions are in mm)

X. PCB Layout and Bezel Recommendations

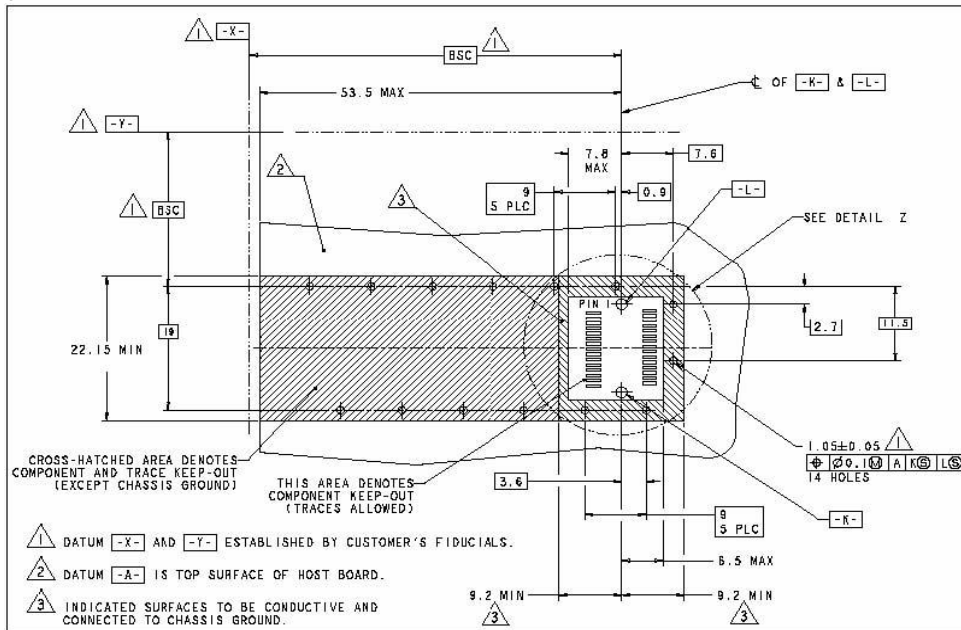

XFP Host Board Mechanical Layout (dimensions are in mm)

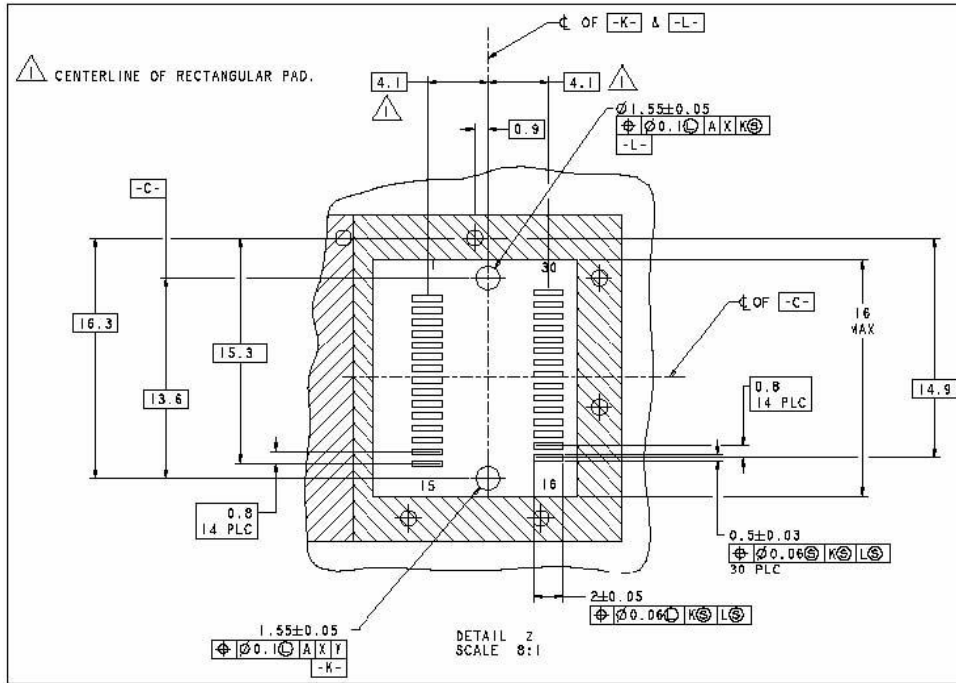

XFP Detail Host Board Mechanical Layout (dimensions are in mm)

