

# QT06025 SERIES



The QT06025 flag ring lug probe sensor is a cost effective solution for surface temperature measurement.



## ENGINEERING INFORMATION

- Available in a variety of sizes with or without insulation
- Standard lug sizes #4 to #12 with additional styles available
- Typical wire sizes #24 to #28 AWG
- Material: tinned copper or nickel-plated steel
- RoHS compliant options available

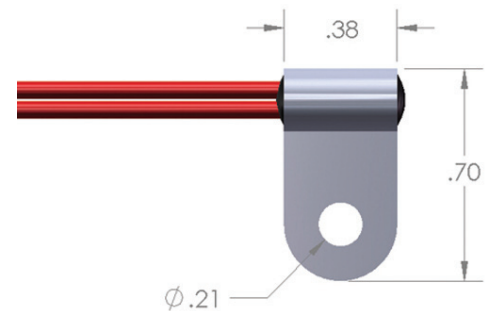

## STANDARD R/T CURVES AND VALUES

### Resistances at 25°C (ohms):

1k, 3k, 5k, 10k, 20k, 30k, 100k

### Curves:

Z, V, M

### Tolerances (+/-):

5%

Additional resistance, curve or tolerance options may be possible. Connector, cable assembly and custom labeling and packaging options are also often available. Contact QTI for details.

QTI can customize this part for you. Contact us for available options.

2108 Century Way Boise, Idaho 83709 USA  
T: (208) 377-3373, 800-554-4784  
F: (208) 376-4754  
qtisales@thermistor.com  
www.thermistor.com

