

水泥電阻器

● 特點

- 雜音低
- 使用於電路板上絕緣度佳
- 耐短時間過負載，阻值長時間無變化
- 耐熱性優電阻溫度係數呈直線變化
- 使用氧化金屬皮膜代替線繞，可製作高阻抗電阻
- 工作溫度範圍
 - 線繞：-40°C ~ +155°C
 - 金屬氧化皮膜：-55°C ~ +155°C
- 定格周圍溫度：1W~10W 70°C
15W以上 25°C

● Features

- Low noise
- Excellent insulation being used in P.C.B.
- Instant overload capability. Long term stability.
- Excellent heat dissipation. Small linear temperature coefficient.
- Metal oxide film cutting core can offer high range resistance (1Ω~100KΩ)
- Operating temperature range
 - Wirewound: -40°C ~ +155°C
 - Metal oxide film: -55°C ~ +155°C
- Rated ambient temperature: 1W~10W 70°C
15W or more 25°C

● 結構圖 Construction

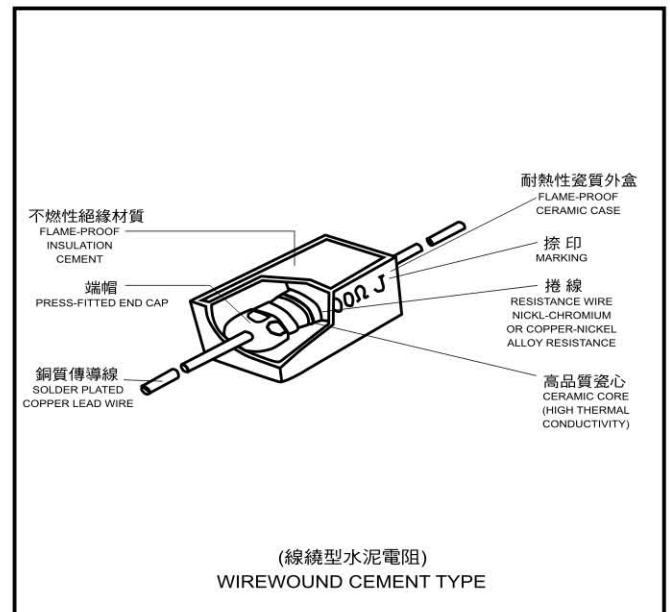
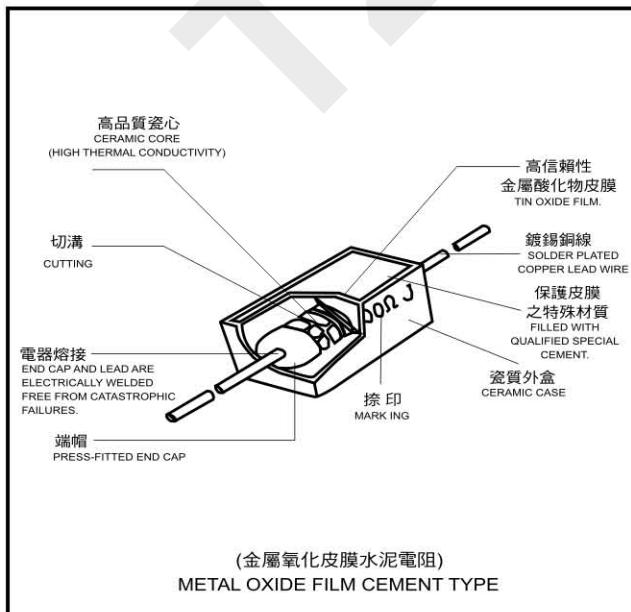

水泥電阻器

規格 Specifications

額定功率 Power Rating	最大工作電壓 Max Working Voltage (RCWV*)	最大過負荷電壓 Max Overload Voltage	耐電壓 Dielectric Withstanding Voltage	最大斷續過負荷電壓 Max Intermittent Overload Voltage
1W	350V	700V	1000V	1500V
2W	350V	700V	1000V	1500V
3W	500V	1000V	1000V	1500V
5W	750V	1500V	1000V	1500V
7W	1000V	1500V	1000V	1500V
10W	1000V	1500V	1000V	1500V
15W	1000V	1500V	1000V	1500V
20W	1000V	1500V	1000V	1500V
30W	1000V	1500V	1000V	1500V
40W	1000V	1500V	1000V	1500V

* 額定電壓 = $\sqrt{\text{額定功率} \times \text{阻抗值}}$ ，額定電壓相當於其最大工作電壓

* RCWV = $\sqrt{\text{Power rating} \times \text{Resistance value of max RCWV listed above whichever less.}}$

SQP

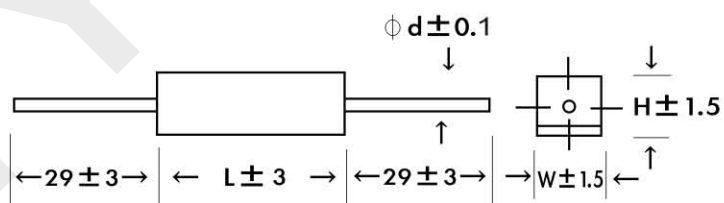

額定功率 Power Rating	L	W	H	φd	阻值範圍 Resistance Range(Ω)	
					SQP (線繞) SQP (Wirewound)	SQP (金屬氧化皮膜) SQP (Metal Oxide Film)
SQP						
1W	14	6.5	6.5	0.8	0.1Ω~22Ω	25Ω~56K
2W	18	7	7	0.8	0.1Ω~22Ω	25Ω~56K
3W	22	8	8	0.8	0.1Ω~47Ω	50Ω~100K
5W	22	10	10	0.8	0.1Ω~47Ω	50Ω~100K
7W	35	10	10	0.8	0.5Ω~330Ω	450Ω~100K
10W	48	10	10	0.8	0.5Ω~450Ω	470Ω~100K
15W	48	12	12	0.8	1Ω~500Ω	510Ω~100K
20W	60	14	14	0.8	1Ω~600Ω	620Ω~100K
30W	75	19	20	0.8	1Ω~600Ω	620Ω~100K
40W	90	19	20	0.8	1Ω~600Ω	620Ω~100K
50W/60W	90	19	20	0.8	1Ω~600Ω	620Ω~100K

水泥電阻器

SQM

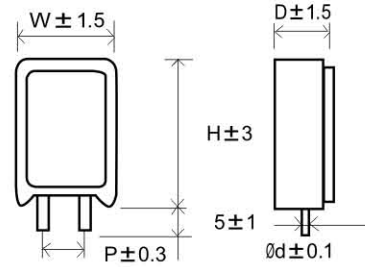

額定功率 Power Rating	尺寸 (mm) Dimension(mm)					阻值範圍 Resistance Range(Ω)	
	W	D	H	P	Ød	SQP (Wirewound)	SQP (Metal Oxide Film)
3W	12	8.5	24	5	0.8	0.1Ω~47Ω	50Ω~100K
5W	13	10	25	5	0.8	0.1Ω~47Ω	50Ω~100K
7W	13	10	39	5	0.8	0.5Ω~330Ω	450Ω~100K
10W	13	10	51	5	0.8	0.5Ω~450Ω	470Ω~100K
10WS	16	12	35	5	0.8	0.5Ω~450Ω	470Ω~100K

SQZ

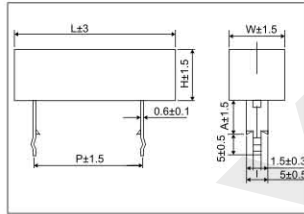

圖一

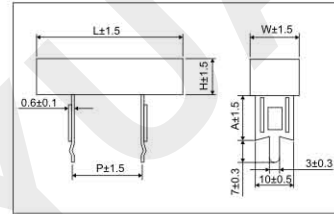

圖二

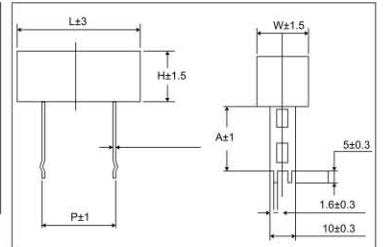

圖三

額定功率 Power Rating	尺寸 (mm) Dimension(mm)					參照圖	阻值範圍 Resistance Range(Ω)	
	W	H	L	P	A		SQZ (線繞) SQZ (Wirewound)	SQZ (金屬氧化皮膜) SQZ (Metal Oxide Film)
5W	10	10	27	15	12	圖一	0.1Ω~47Ω	50Ω~100KΩ
7W	10	10	35	20	12	圖一	0.5Ω~330Ω	450Ω~100KΩ
10W	10	10	48	32	12	圖一	0.5Ω~450Ω	470Ω~100KΩ
15W	12	12	48	32	10	圖一	1Ω~500Ω	510Ω~100KΩ
20W	14	12	64	44	10	圖一/圖二	1Ω~600Ω	620Ω~100KΩ
25W	14	13	64	48	10	圖一/圖二	1Ω~600Ω	620Ω~100KΩ
30W	20	20	76	54	22	圖二	1Ω~600Ω	620Ω~100KΩ
40W	20	20	84	70	22	圖二	1Ω~600Ω	620Ω~100KΩ
50W	20	20	90	70	22/11	圖二	1Ω~600Ω	620Ω~100KΩ
60W	20	20	90	70	24	圖二/圖三	1Ω~600Ω	620Ω~100KΩ
100W	24	24	135	115	24	圖二/圖三	1Ω~600Ω	620Ω~100KΩ

SPS

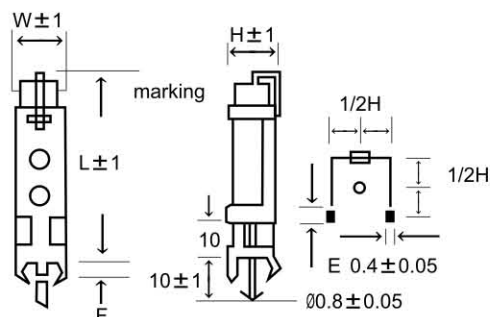

水泥電阻器

額定功率 Power Rating	尺寸 (mm) Dimension(mm)					阻值範圍 Resistance Range(Ω)	
	W	H	L	E	F	SPS (Wirewound)	SPS (Metal Oxide Film)
5W	11	11	25	1.4	4	0.1Ω~47Ω	50Ω~100K
7W	11	11	37	1.4	4	0.5Ω~330Ω	450Ω~100K
10W	11	11	50	1.4	4	0.5Ω~450Ω	470Ω~100K
15W	15	15	50	2.5	4.5	1Ω~500Ω	510Ω~100K
20W	16	15	63	2.5	4.5	1Ω~600Ω	620Ω~100K

* 以上尺寸可供參考，具體尺寸可以客人要求訂製。

SQHG

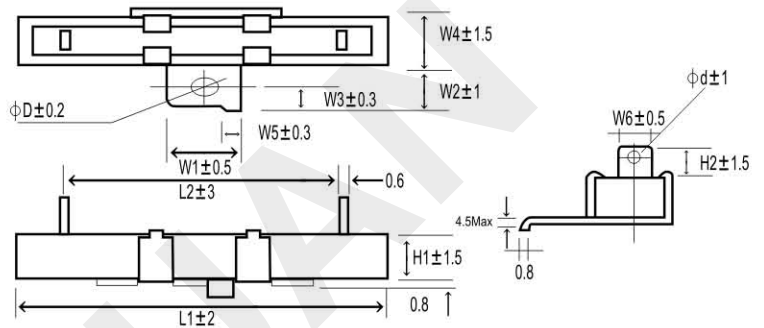
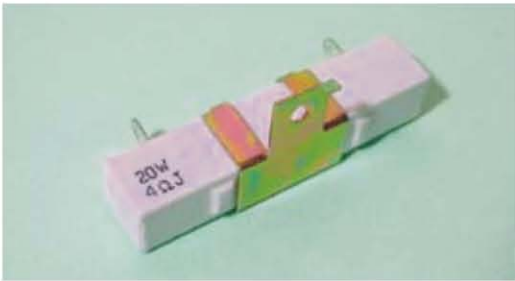

額定功率 Power Rating	尺寸 (mm) Dimension(mm)											阻值範圍 Resistance Range(Ω)		
	W1	W2	W3	W4	W5	W6	L1	L2	H1	H2	φD	φd	SQHG (Wirewound)	SQHG (Metal Oxide Film)
10W	12	14	6	10	3	5.5	48	30	10.5	7	3.8	2.5	0.5Ω~450Ω	470Ω~100K
15W	12	14	6	12	3	6	48	31.5	12.5	7	3.8	2.5	1Ω~500Ω	510Ω~100K
20W	12	14	6	12	3	6	63	42	14	7	3.8	2.5	1Ω~600Ω	620Ω~100K
30W	17	15.5	6	19	3	8	78	53	19	9	4.5	3	2Ω~500Ω	510Ω~100K
40W/50W	17	15.5	6	19	3	8	90	70	19	9	4.5	3	0.1Ω~600Ω	620Ω~100K

* 以上尺寸可供參考，具體尺寸可以客人要求訂製。

SQH

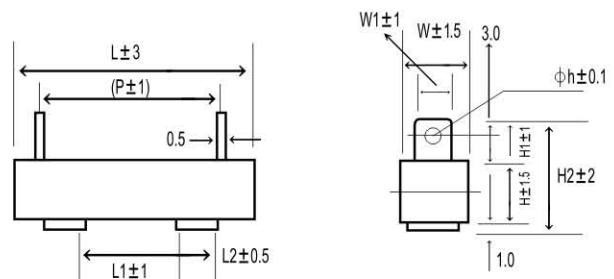
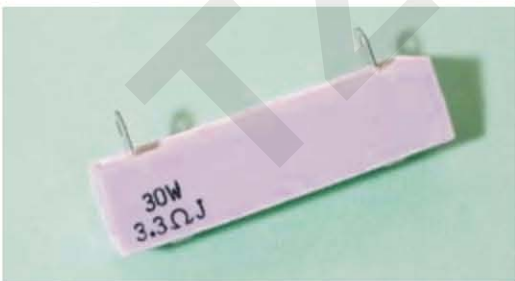

額定功率 Power Rating	尺寸 (mm) Dimension(mm)										阻值範圍 Resistance Range(Ω)	
	P	L	L1	L2	H	H1	H2	W	W1	φh	SQH (Wirewound)	SQH (Metal Oxide Film)
10W	30	48	25	4	10.5	7.5	18	10	5	2.5	0.5Ω~450Ω	470Ω~100K
15W	32	48	25	4	12.5	7.5	21	12.5	6	2.5	1Ω~500Ω	510Ω~100K
20W	43	63	25	4	13	7.5	22	12	6	2.5	1Ω~600Ω	620Ω~100K
30W	54	78	42	4	19	10	30	19	7.5	3	2Ω~700Ω	510Ω~100K
40W	68	90	42	7	19	10	30	19	7.5	3	2Ω~820Ω	620Ω~100K
50W/60W	70	90	51	7	19	12	30	19	7.5	3	2Ω~820Ω	620Ω~100K

* 以上尺寸可供參考，具體尺寸可以客人要求訂製。

水泥電阻器

SQG

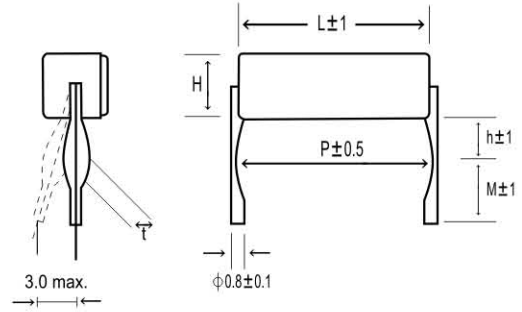
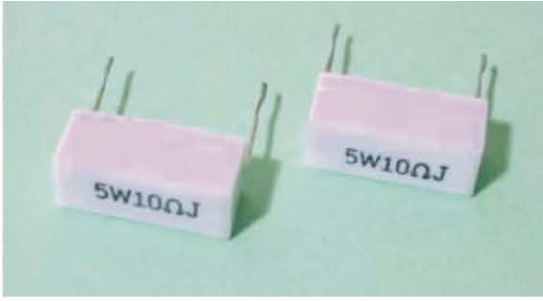

額定功率 Power Rating	尺寸 (mm) Dimension(mm)						阻值範圍 Resistance Range(Ω)	
	P	H	L	M	t	h	SQG (Wirewound)	SQG (Metal Oxide Film)
3W	20	8	22	5	1.3	5.5	0.1Ω~47Ω	50Ω~100K
5W	20	10	22	5	1.3	5.5	0.1Ω~47Ω	50Ω~100K

*以上所有水泥電阻規格尺寸可供參考，具體可依客人要求制訂

● 負載遞減曲線 Power Derating Curve

線繞型水泥電阻 Wirewound Cement Type

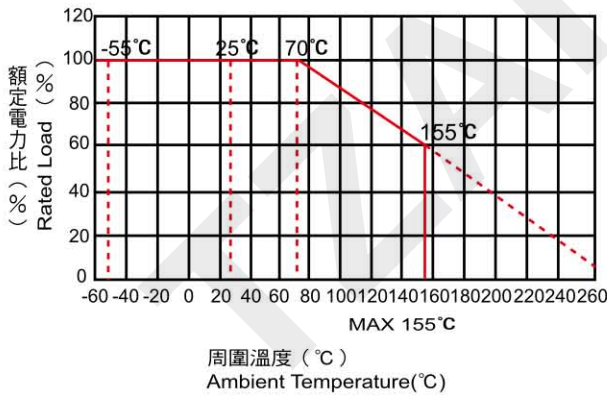

金屬氧化皮膜水泥電阻 Metal Oxide Film Cement Type

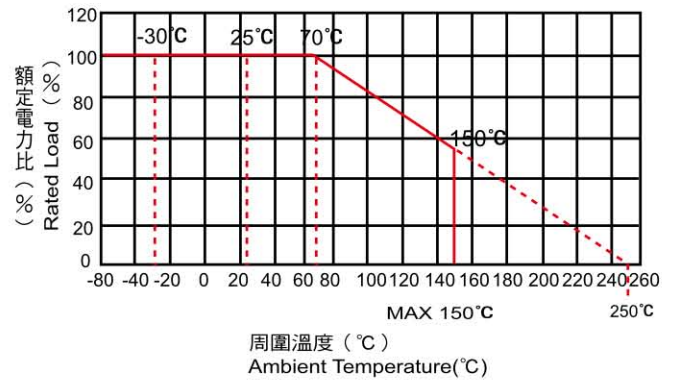

● 表面溫度上升 Hot-spot Temperature

水泥金屬氧化皮膜電阻器

表面溫度上升 HOT-SPOT TEMPERATURE

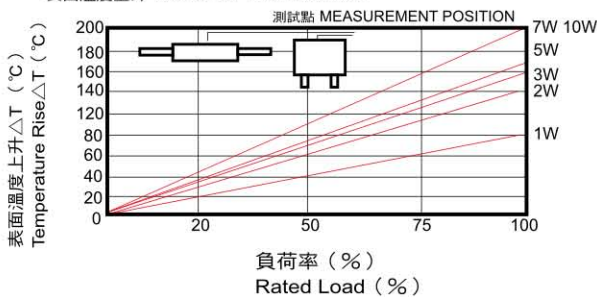

水泥線繞電阻器

表面溫度上升 HOT-SPOT TEMPERATURE

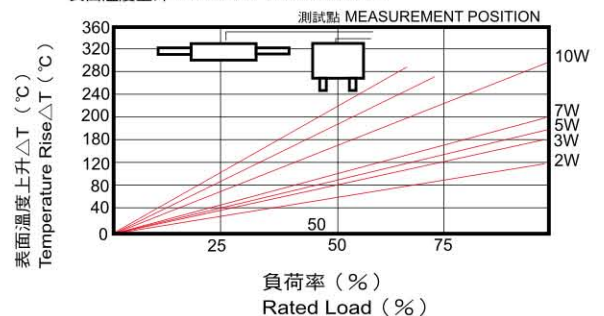

水泥電阻器

品名構成 Product Identification

SQ(?)	5W	1K3	J (±5%)
種類	額定功率	公稱抵抗值	容許誤差值
Type	Power Rating	Resistance	Tolerance
種類 Type		容許誤差值 Tolerance	
SQZ	SQM	SQH	SQHG
SQP		SPS	SQG
			G
			J
			K
			±2%
			±5%
			±10%

特性 Characteristics

特性項目 Item	規格值 Specification	試驗方式 Test Method	JIS.C.5202
溫度係數 Temperature Coefficient	金屬氧化皮膜：±350ppm/°C Metal Oxide Film: ±350ppm/°C 電阻線：±260ppm/°C Resistor Wire: ±260ppm/°C		
短時間過負荷 Short Time Over Load	±(2%+0.05Ω)MAX	定格電力X10倍，5秒。 Rated power X 10 times, 5 seconds	
絕緣阻抗 Insulation Resistance	1000MΩ MIN		
耐電壓 Dielectric Withstanding Voltage	無燒損或絕緣性破壞 No flashover or insulation damage	加AC電壓於各規格中持續1分鐘 AC Potential repectively specified in the list for 60 seconds	
負荷壽命 Load Life	±(5%+0.05Ω)MAX	在溫度70°C環境，額定電壓1.5小時「ON」，0.5小時「OFF」持續1000小時 Rated voltage 1.5hr "on", 0.5hr "off" at 70°C for 1000 hrs.	
耐濕負荷 Load Life in Moisture	±(5%+0.05Ω)MAX	在溫度40°C，溼度95%RH環境額定電壓1.5小時「ON」，0.5小時「OFF」持續1000小時 Rated voltage 1.5hr "on", 0.5hr "off" at 40°C, 95% RH. for 1000 hrs.	