

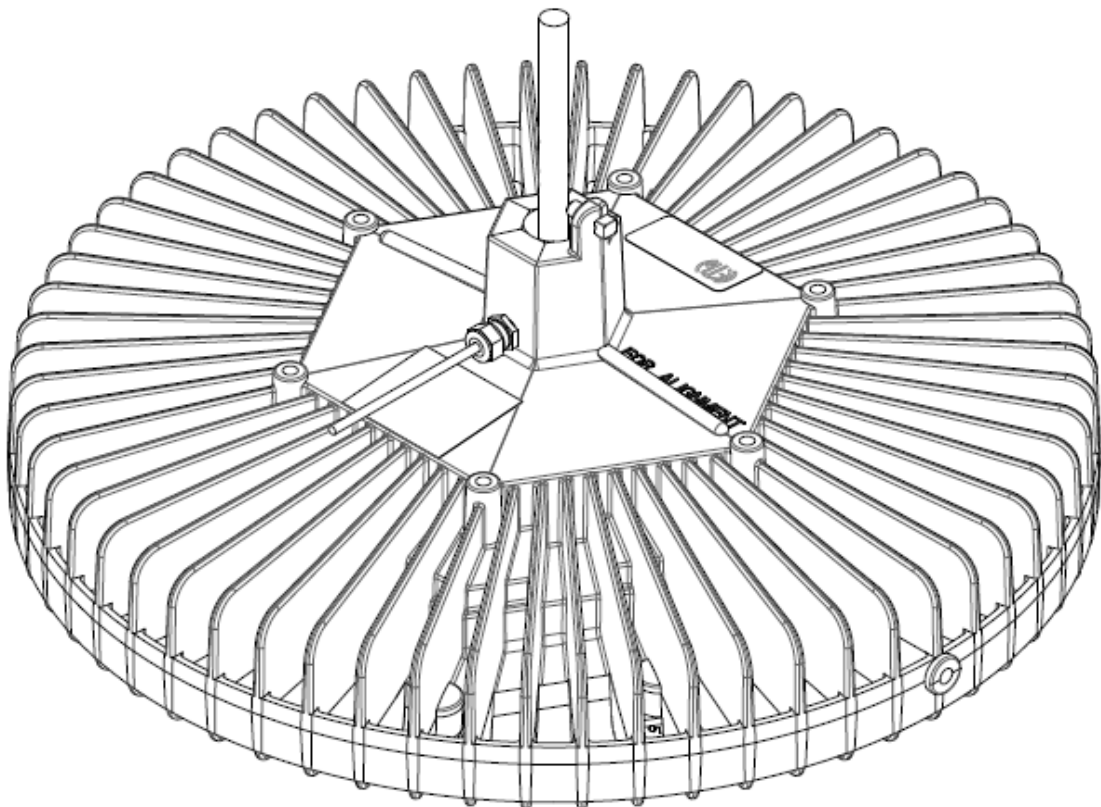

INSTALLATION AND MAINTENANCE MANUAL
DUROSITE™ SERIES LED LOW BAY
Document No: 9100-127-1496-99 Rev A
March 2011

MODEL #

LBW1C5D



1: Introduction

This Low Bay light is designed for illumination of industrial locations. It uses the latest in solid state lighting technology for long life, low maintenance, and high efficiency.

The unique optical design focuses light downward to where it is needed, giving improved efficiency over a conventional HID luminaire.

An internal power-factor-corrected switch-mode supply allows it to be used from any nominal 100V-277V, 50/60Hz AC supply without any variation in light output.

A 2 conductor, 18 AWG, plenum-rated cable is provided for dimming control. The cable jacket is red in color and contains one black conductor and one red conductor. Dimming is controlled by means of a 0-10 VDC signal (to be provided by the installer) to control the level of dimming. At 10 volts, the output of the unit is 100%; at 0 volts, the output will be approximately 15%. The DC dimming voltage should not exceed 15 VDC. Increasing the voltage from 10VDC to 15VDC will not result in additional light output.

Model LBW1C5D is suitable for use in the following locations:

- Wet Locations as per UL 1598
- Outdoor Type (Salt Water) as per UL 1598A

Note: Save these instructions for future reference.

2: Installation

⚠ Warning:

To avoid the risk of fire, explosion, or electric shock, this product should be installed, inspected, and maintained by a qualified electrician only, in accordance with all applicable electrical codes.

⚠ Warning:

To avoid electric shock:

- Be certain electrical power is OFF before and during installation and maintenance.
- Luminaire must be connected to a wiring system with an equipment-grounding conductor.

⚠ Warning:

- Make sure the supply voltage is the same as the rated luminaire voltage.
- Do not operate in ambient temperatures above those indicated on the luminaire nameplate.

Recommended mounting height: 12-20 feet



Pendent Mount Installation Steps:

- For maximum long term reliability and light output, the light must be installed in free air.
 - The Low Bay fixture design incorporates an over-temperature control circuit that reduces input power should internal temperatures reach a maximum level. As a result, light output may be reduced.
- The Low Bay fixture is threaded for 3/4" NPT in order to be assembled to conduit.
 - Calculate and measure required conduit length.
 - Feed the power cable through the conduit and into the junction box.
 - Attach the fixture to the conduit (**using Teflon tape or pipe sealant**).
 - Insert 1/4-20 anti-rotation screw in order to secure the fixture to the conduit.
- Connect power cable conductors as follows:
 - Green wire connects to Safety Ground.
 - White wire connects to Neutral
 - Black wire connects to Live
- Restore power and verify operation.

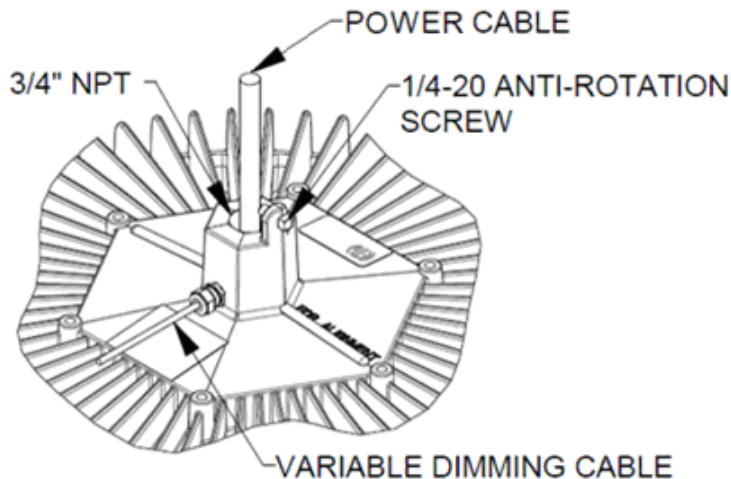

Dialight Low Bay Variable Dimming:

The Dialight Low Bay fixture supports variable dimming through a two wire interface. Using this interface, it is possible to reduce the light level of the fixture, saving energy and setting the level exactly as desired.

The dimmable Low Bay has a two cable (five wires total) interface. The power cable houses two wires which are used to power the unit (Black and White, Hot and Neutral, respectively), and one which is used as a safety ground/Earth (Green). The other cable houses two wires (Red and Black) which form the dimming interface and can be used in the ways described below.

Important Notes

- The low voltage Dimming wires are connected to the grounded output section of the driver inside the light. Never connect either one to the Hot or Neutral supply wires.
- The '-' wire (Black) is at ground potential.
- Never use these wires for any purpose other than dimming.



1) Variable Voltage Control

An analog 0-10V active dimmer may be connected to the two wires to control the light output of the fixture. Multiple lights may be connected to the same dimmer, as long as the maximum current rating of the dimmer is not exceeded.

The dimmer must be capable of sinking 0.5mA per light. Light output will vary approximately linearly with control voltage, with 10V corresponding to 100% light output.

Note: If the control voltage exceeds 10V the light output will not increase beyond the normal maximum brightness, but it is recommended that the control voltage be limited to under 15V.

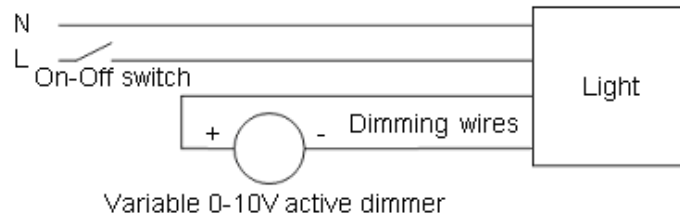

Example Application of Adjustable Brightness Using Active Analog Dimmer

2) Step dimming

Simply shorting the two wires together will cause the light to dim to a low level, as shown below. When this is done, the light will dim down to approximately 15% of its full light output, with a corresponding decrease in input power.

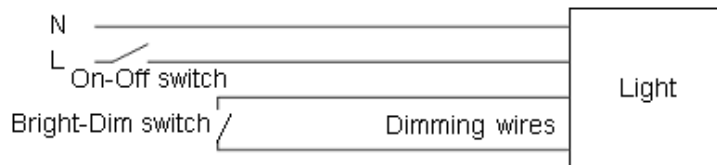

Example Application of Step dimming using 0-10V Wires

Interfacing to an Occupancy Sensor:

The Dialight Low Bay fixture is ideally suited for control by an occupancy sensor in order to maximize energy savings based on its instant-on behavior and low power consumption. Instructions for connecting the High Bay fixture to an occupancy sensor are listed below.

WARNING: TO BE INSTALLED AND/OR USED IN ACCORDANCE WITH APPROPRIATE ELECTRICAL CODES AND REGULATIONS.

WARNING: CONTROLLING A LOAD IN EXCESS OF THE SPECIFIED RATINGS OF THE OCCUPANCY SENSOR COULD DAMAGE THE UNIT AND POSE RISK OF FIRE, ELECTRIC SHOCK, PERSONAL INJURY, OR DEATH. CHECK LOAD RATINGS TO DETERMINE THE UNIT'S SUITABILITY FOR YOUR APPLICATION.

NOTE: SEE OCCUPANCY SENSOR INSTALLATION INSTRUCTIONS FOR ADDITIONAL INFORMATION.



- 1) **WARNING: TO AVOID FIRE, SHOCK OR DEATH, TURN OFF POWER AT CIRCUIT BREAKER OR FUSE AND TEST THAT THE POWER IS OFF BEFORE WIRING.**
- 2) Install occupancy sensor as per sensor instructions to provide desired coverage of area.
- 3) Connect luminaire wires per wiring diagram as follows: Black lead to load of the occupancy sensor, White lead to the line (neutral), Green lead to earth ground. Multiple fixtures may be connected to a sensor, as long as the rated load of the sensor is not exceeded.
- 4) Restore power at circuit breaker or fuse.
- 5) Verify operation of system. If the light will not turn on, check the operation of the fixture and sensor individually, and check that the wiring is done correctly. If the light will not turn off or it turns off and on quickly, see the sensor's installation instructions for further guidance.

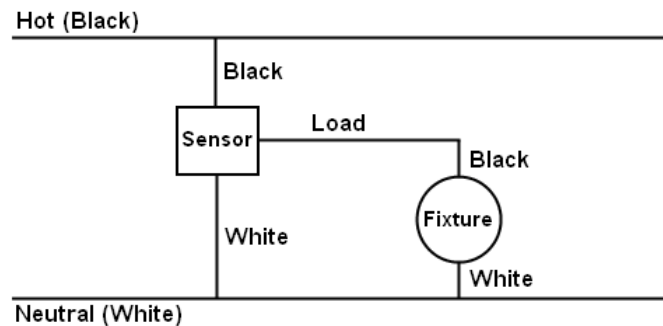

3: Maintenance

- To avoid personal injury, disconnect power to the light and allow the unit to cool down before performing maintenance.
- ⚠ Warning:** No user serviceable parts inside of fixture. Risk of electric shock. Removal of the lens will void the warranty.
- 1) Perform visual, mechanical and electrical inspections on a regular basis. We recommend routine checks to be made on a yearly basis. Frequency of use and environment should determine this. It is recommended to follow an Electrical Preventive Maintenance Program as described in NFPA 70B: Recommended Practice for Electrical Equipment.
 - 2) The lens should be cleaned periodically as needed to ensure continued photometric performance. Clean the lens with a damp, non-abrasive, lint-free cloth. If not sufficient, use mild soap or a liquid cleaner. Do not use an abrasive, strong alkaline or acid cleaner as damage may occur.
 - 3) Inspect the cooling fins on the luminaire to ensure that they are free of any obstructions or contamination (i.e. excessive dust build-up). Clean with a non-abrasive cloth if needed.

4. Specifications

Nominal AC Supply Voltage	100-277VAC, 50/60Hz
Power consumption	80W nominal
Operating temperature range	-40°C to +65°C [-40°F to +149°F]
Power factor	>0.9
ATHD	<15%
Dimensions (Height x Diameter)	8" x 16" [20.3cm x 40.6cm]
Weight	18 lbs [8.2 kg]

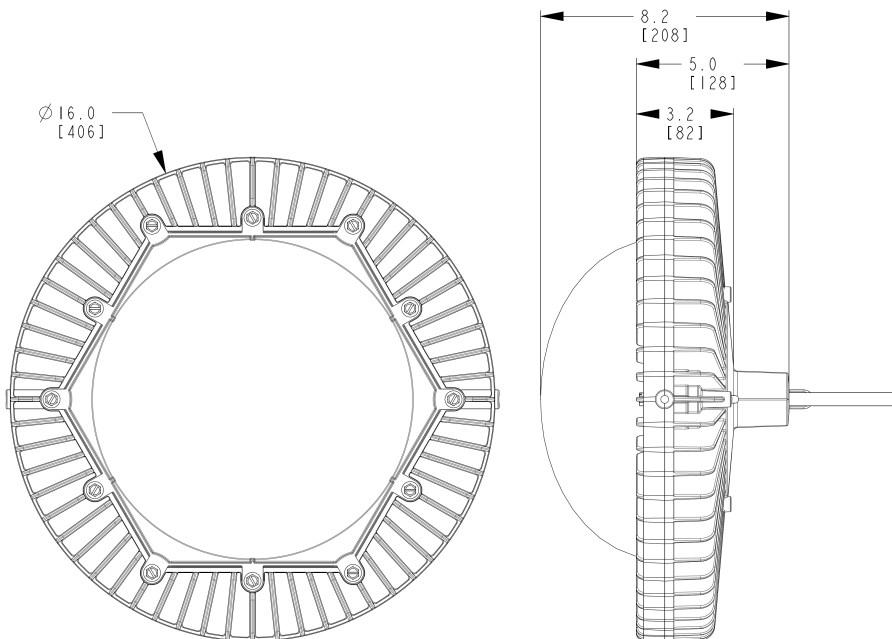

DIMENSIONS ARE FOR REFERENCE ONLY.

All statements, technical information and recommendations contained herein are based on information and tests we believe to be reliable. The accuracy or completeness thereof is not guaranteed. In accordance with Dialight Corporation "Terms and Conditions of Sale", and since conditions of use are outside our control, the purchaser should determine the suitability of the product for his intended use and assumes all risk and liability whatsoever in connection therewith.

<u>REV.</u>	<u>ECO No.</u>	<u>DRN</u>	<u>CHK</u>	<u>APP</u>	<u>QA</u>	<u>CM</u>	<u>DATE</u>
A	-----	KLJ	KH	RHF	RL	JB	3-23-11

