

QUARTZ CRYSTALS

US ELECTRONICS INC.

PH:(314)423-7550

FAX:(314)423-0585

HC49/S Package Crystals

- ATS Holder type package
- AT or BT cut available
- Resistance weld seal
- Tape and reel, insulator tab, 3rd lead, and custom lead length options available
- Tight tolerance / stability

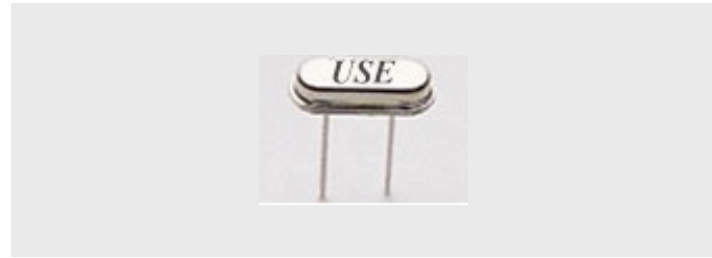

Standard Frequencies for ATS25/U Package:

USE Part #	Frequency (MHz)	Load cap.	Max.ESR
LPC036	3.5795	16	180
LPC040	4.0000	20	150
LPC041	4.1943	16	150
LPC049	4.9152	20	120
LPC050	5.0688	20	120
LPC051	5.1850	32	120
LPC060	6.0000	32	100
LPC061	6.1440	20	100
LPC074	7.3728	20	100
LPC080	8.0000	Series	80
LPC081	8.0000	20	80
LPC090	9.0000	Series	80
LPC098	9.8300	20	80
LPC100	10.0000	Series	70
LPC101	10.0000	30	70

Standard Frequencies for ATS25/U Package:

USE Part #	Frequency (MHz)	Load cap.	Max.ESR
LPC107	10.7386	32	70
LPC110	11.0592	Series	70
LPC120	12.0000	32	60
LPC122	12.2880	32	60
LPC143	14.3181	Series	60
LPC147	14.7456	Series	60
LPC150	15.0000	Series	60
LPC160	16.0000	20	50
LPC180	18.0000	Series	50
LPC184	18.4320	20	50
LPC185	18.4320	Series	50
LPC196	19.6608	Series	50
LPC200	20.0000	20	40
LPC221	22.1184	Series	40
LPC240	24.0000	Series	40

Standard Specifications:

Frequency Range	3.5 - 85 MHz
Vibration Mode	At cut fundamental and third
Frequency Tolerance	+/- 0.005% (50 ppm) @ 25°C
Operating Temp Range and Frequency Stability	+/- 0.005% (50 ppm) over -20°C to 70°C
Shunt Capacitance	7pF maximum or special
Insulation Resistance	500Meg.Ohms
Aging	+/-5 ppm / year
Package	Resistance weld low profile, ATS25/U , 3.5mm tall

How To Order: 1. Pick a part# from the standard parts table or pick a frequency with in the range specified in the table above and specify the properties you need from the tables below to configure the part# you need.

2. If you need Insulator, add "I" in the box specified.

3. If you need [Tape & Reel](#), add "TR" in the box specified at the end of the part number.

4. To [Place Order](#) specify part number and quantity

CUSTOM PART NUMBERING SYSTEM

Frequency(MHz) Insulator Tape & Reel

MECHANICAL DIMENSIONS

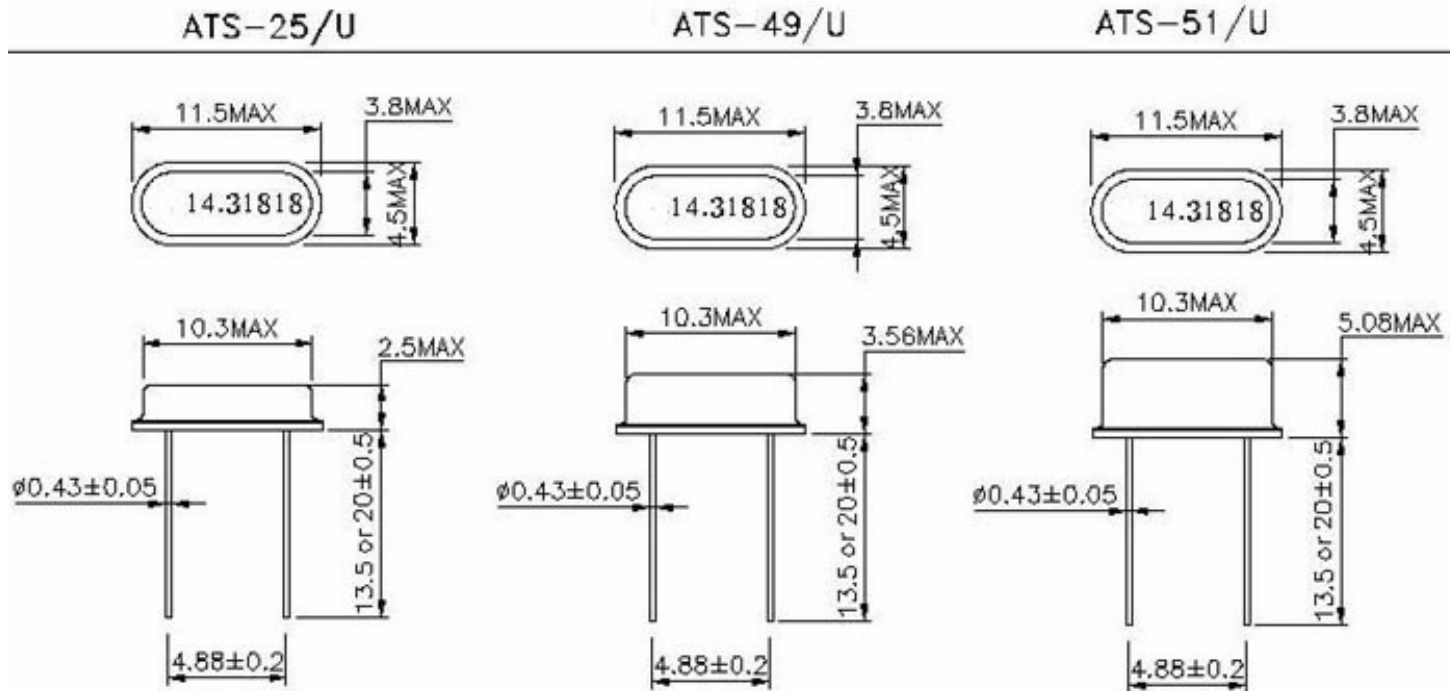

Tape and Reel Specifications For HC-49/S Package (DIP TYPE)

• **Tape specification**

Item 1:

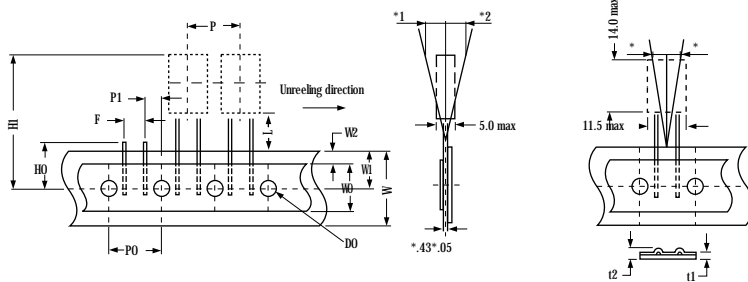

Item 2:

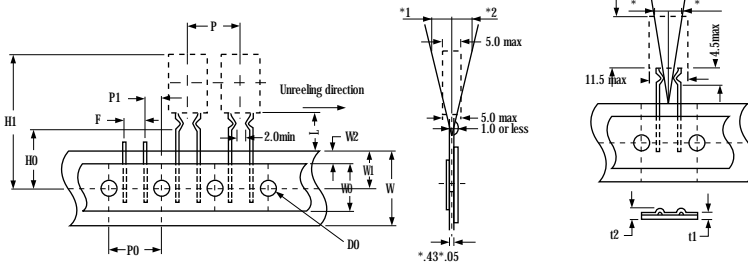

Symbol	Dimension tolerance(mm)	
P	12.7 *1.0	
P0	12.7 *0.3	
P1	3.85 *0.7	
F	5.0 *0.8	
W	18.0 + 1.0 / -0.5	
W0	12.5 or more	
W1	9.0 + 0.75 / -0.5	
W2	3.0 or less	
D0	4.0 *0.2	
L	9.5 or more	
t1	0.6 *0.3	
t2	1.5 or less	
*1	2.0 or less	
*2	2.0 or less	
*	2.0 or less	
H0		16.0 *0.5
H1	34.46 or less	

• **Reel specification**

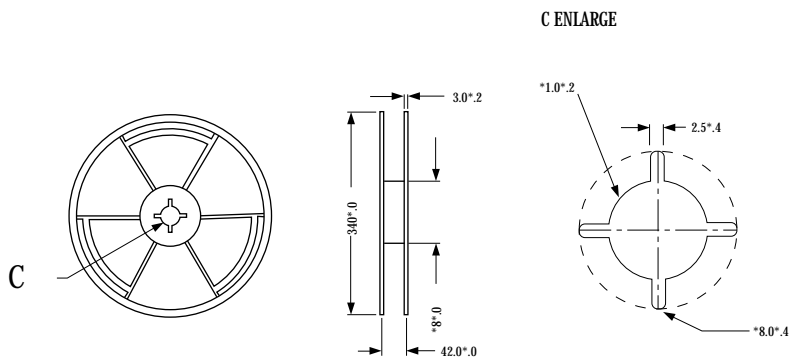

• **TAPE ARRANGE**

