

| | | | | |
|-----|-------------|--------|-------|------|
| REV | DESCRIPTION | DATE | PREP | APPD |
| M | CO-25772 | 1/5/16 | DF/SM | LT |



EXAMPLES SHOWN IN ACTUAL SIZE

| | | | | |
|--|--|-------------------------------|------------------|----------------------|
|  MOUNT HOLLY SPRINGS, PA 17065 | Oscillator Specification, Hybrid Clock Hi-Rel Standard | | | |
| | THE RECORD OF APPROVAL FOR THIS DOCUMENT IS MAINTAINED ELECTRONICALLY WITHIN THE ERP SYSTEM | CODE IDENT NO 00136 | SIZE A | DWG. NO. OS-68338 |
| UNSPECIFIED TOLERANCES: N/A | | | | SHEET 1 OF 31 |

1. SCOPE

- 1.1 General. This specification defines the design, assembly and functional evaluation of high reliability, hybrid clock oscillators produced by Vectron International. Devices delivered to this specification represent the standardized Parts, Materials and Processes (PMP) Program developed, implemented and certified for advanced applications and extended environments.
- 1.2 Applications Overview. The designs represented by these products were primarily developed for the MIL-Aerospace community. The lesser Design Pedigrees and Screening Options imbedded within OS-68338 bridge the gap between Space and COTS hardware by providing custom hardware with measures of mechanical, assembly and reliability assurance needed for Military or Ruggedized COTS environments.

2. APPLICABLE DOCUMENTS

- 2.1 Specifications and Standards. The following specifications and standards form a part of this document to the extent specified herein. The issue currently in effect on the date of quotation will be the product baseline, unless otherwise specified. In the event of conflict between the texts of any references cited herein, the text of this document shall take precedence.

Military

MIL-PRF-55310 Oscillators, Crystal Controlled, General Specification For
MIL-PRF-38534 Hybrid Microcircuits, General Specification For

Standards

MIL-STD-202 Test Method Standard, Electronic and Electrical Component Parts
MIL-STD-883 Test Methods and Procedures for Microelectronics

Other

DOC007131 Test Specification, OS-68338 Hybrids, Hi-Rel Standard
QSP-90100 Quality Systems Manual, Vectron International
DOC011627 Identification Common Documents, Materials and Processes, Hi-Rel XO
DOC203982 DPA Specification
QSP-91502 Procedure for Electrostatic Discharge Precautions

3. GENERAL REQUIREMENTS

- 3.1 Classification. All devices delivered to this specification are of hybrid technology conforming to Type 1, Class 2 of MIL-PRF-55310. Primarily developed as a Class S equivalent specification, options are imbedded within it to also produce Class B, Engineering Model and Ruggedized COTS devices. Devices carry a Class 2 ESDS classification per MIL-PRF-38534.
- 3.2 Item Identification. External packaging choices are of metal flatpacks, DIP's and ceramic J-lead 9x14mm and LCC's with either TTL or ACMOS logic output. Unique Model Number Series' are utilized to identify device package configurations and output logic as listed in Table 1.

| | | | | | | |
|------------------|--------------------------------|---|--------------------------------------|----------------------------|------------------|-------------------|
| SIZE A | CODE IDENT NO. 00136 | THIRD ANGLE PROJECTION  | UNSPECIFIED TOLERANCES N/A | DWG NO. OS-68338 | REV. M | SHEET 2 |
|------------------|--------------------------------|---|--------------------------------------|----------------------------|------------------|-------------------|

- 3.3 Absolute Maximum Ratings.
- a. Supply Voltage Range (V_{CC}): -0.5Vdc to +7.0Vdc
 - b. Storage Temperature Range (T_{STG}): -65°C to +125°C
 - c. Junction Temperature (T_J): +175°C
 - d. Lead Temperature (soldering, 10 seconds): +300°C
 - e. Output Source/Sink Current: ±70 mA

3.4 Design, Parts, Materials and Processes, Assembly, Inspection and Test.

3.4.1 Design. The ruggedized designs implemented for these devices are proven in military and space applications under extreme environments. All designs (except Model 1157) utilize a 4-point crystal mount in compliment with Established Reliability (MIL-ER) componentry. The Model 1157 utilizes a 3-point crystal mount and replaces the Model 1118 which utilized a 2-point crystal mount. When specified, radiation hardening up to 100krad(Si) (RHA level R) can be included without altering the device's internal topography.

3.4.1.1 Design and Configuration Stability. Barring changes to improve performance by reselecting passive chip component values to offset component tolerances, there will not be fundamental changes to the design or assembly or parts, materials and processes after first product delivery of that item without written approval from the procuring activity.

3.4.1.2 Environmental Integrity. Designs have passed the environmental qualification levels of MIL-PRF-55310. These designs have also passed extended dynamic levels of at least:

- a. Sine Vibration: MIL-STD-202, Method 204, Condition G (30g pk.)
- b. Random Vibration: MIL-STD-202, Method 214, Condition II-J (43.92g rms, three minute duration in each of three mutually perpendicular directions)
- c. Mechanical Shock: MIL-STD-202, Method 213, Condition F (1500g, 0.5ms)

3.4.2 Prohibited Parts, Materials and Processes. The items listed are prohibited for use in high reliability devices produced to this specification.

- a. Gold metallization of package elements without a barrier metal.
- b. Zinc chromate as a finish.
- c. Cadmium, zinc, or pure tin external or internal to the device.
- d. Plastic encapsulated semiconductor devices.
- e. Ultrasonically cleaned electronic parts.
- f. Heterojunction Bipolar Transistor (HBT) technology.
- g. 'getter' materials

3.4.3 Assembly. Manufacturing utilizes standardized procedures, processes and verification methods to produce MIL-PRF-55310 Class S / MIL-PRF-38534 Class K equivalent devices. MIL-PRF-38534 Group B Option 1 in-line inspection is included on radiation hardened part numbers to further verify lot pedigree. Traceability of all components and production lots are in accordance with MIL-PRF-38534, as a minimum. Tabulated records are provided as a part of the deliverable data package. Devices are handled in accordance with Vectron document QSP-91502 (Procedure for Electrostatic Discharge Precautions).

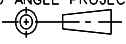
| | | | | | | |
|------------------|--------------------------------|---|--------------------------------------|----------------------------|------------------|-------------------|
| SIZE A | CODE IDENT NO. 00136 | THIRD ANGLE PROJECTION  | UNSPECIFIED TOLERANCES N/A | DWG NO. OS-68338 | REV. M | SHEET 3 |
|------------------|--------------------------------|---|--------------------------------------|----------------------------|------------------|-------------------|

- 3.4.4 Inspection. The inspection requirements of MIL-PRF-55310 apply to all devices delivered to this document. Inspection conditions and standards are documented in accordance with the Quality Assurance, ISO-9001 and AS9100 derived, System of QSP-90100.
- 3.4.5 Test. The Screening test matrix of Table 5 is tailored for selectable-combination testing to eliminate costs associated with the development/maintenance of device-specific documentation packages while maintaining performance integrity.
- 3.4.6 Marking. Device marking shall be in accordance with the requirements of MIL-PRF-55310.
- 3.4.7 Ruggedized COTS Design Implementation. Design Pedigree “D” devices (see ¶ 5.2) use the same robust designs found in the other device pedigrees. They do not include the provisions of traceability or the Class-qualified componentry noted in paragraphs 3.4.3 and 4.1.

4. DETAIL REQUIREMENTS

4.1 Components

- 4.1.1 Crystals. Cultured quartz crystal resonators are used to provide the selected frequency for the devices. The optional use of Premium Q swept quartz can, because of its processing to remove impurities, be specified to minimize frequency drift when operating in radiation environments. In accordance with MIL-PRF-55310, the manufacturer has a documented crystal element evaluation program.
- 4.1.2 Passive Components. Passive components will have the same pedigree as the die specified in paragraph 7.1. When required, Established Reliability (ER) failure level R minimum passive components are used to the maximum extent possible and procured from QPL suppliers. Lot evaluations are in accordance with MIL-PRF-38534 or Enhanced Element Evaluation as specified in Table 7. When used, inductors may be open construction and may use up to 47 gauge wire.
- 4.1.3 Class S Microcircuits. Microcircuits are procured from wafer lots that have passed MIL-PRF-38534 Class K Lot Acceptance Tests for Class S devices. The prescribed die carries a Class 2 ESDS classification in accordance with MIL-PRF-38534. When optionally specified, further testing in accordance with MIL-PRF-55310 and MIL-PRF-38534 is performed for radiation hardness assurance and for Enhanced Element Evaluation as specified in Table 6. Those microcircuits, identified by a unique part number, are certified for 100krad(Si) total ionizing dose (TID), RHA level R (2X minimum margin). NSC, as the original 54ACT designer, rates the SEU LET at >40 MeV and SEL at >120MeV for the FACT™ family (AN-932). Vectron has conducted additional SEE testing in 2008 to verify this performance since our lot wafer testing does not include these parameters and determinations.
- 4.1.3.1 Class B Microcircuits. When specified, microcircuits assembled into OS-68338 Design Pedigree letters “B” and “C” devices (¶ 5.2a) are procured from wafer lots that have passed MIL-PRF-55310 element evaluations for Class B devices.

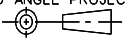
| | | | | | | |
|------------------|--------------------------------|---|--------------------------------------|----------------------------|------------------|-------------------|
| SIZE A | CODE IDENT NO. 00136 | THIRD ANGLE PROJECTION  | UNSPECIFIED TOLERANCES N/A | DWG NO. OS-68338 | REV. M | SHEET 4 |
|------------------|--------------------------------|---|--------------------------------------|----------------------------|------------------|-------------------|

- 4.1.4 Packages. Packages are procured that meet the construction, lead materials and finishes as specified in MIL-PRF-55310. Package lots are upscreened in accordance with the requirements of MIL-PRF-38534 as applicable.
- 4.1.5 Traceability and Homogeneity. All design pedigrees except option D have active device lots that are traceable to the manufacturer's individual wafer; all other elements and materials are traceable to their manufacturer and incoming inspection lots. Design pedigrees E, R, V and X have homogenous material. In addition, swept quartz crystals are traceable to the quartz bar and the processing details of the autoclave lot, as applicable.
- 4.1.6 Enhanced Element Evaluation. When Design Pedigree Option "E" is specified, active and passive devices with Enhanced Element Evaluation as listed in Table 6 and 7 shall be implemented for the highest reliability preference.
- 4.2 Mechanical.
- 4.2.1 Package Outline. Table 1 links each Hi-Rel Standard Model Number of this specification to a corresponding package style. Mechanical Outline information of each package style is found in the referenced Figure.
- 4.2.2 Thermal Characteristics. The worst case thermal characteristics of each package style are found in Table 4.
- 4.3 Electrical.
- 4.3.1 Input Power. Devices are available with an input voltage of either +5.0 Vdc ($\pm 10\%$) or +3.3 Vdc ($\pm 10\%$). Current is measured, no load, at maximum rated operating voltage.
- 4.3.2 Temperature Range. Operating range is -55°C to $+125^{\circ}\text{C}$.
- 4.3.3 Frequency Tolerance. Initial accuracy at $+23^{\circ}\text{C}$ is ± 15 ppm maximum. Frequency-Temperature Stability is ± 50 ppm maximum from $+23^{\circ}\text{C}$ reference. Frequency-Voltage Tolerance is ± 4 ppm maximum.
- 4.3.4 Frequency Aging. Aging limits, and when tested in accordance with MIL-PRF-55310 Group B inspection, shall not exceed ± 1.5 ppm the first 30 days, ± 5 ppm Year 1 and ± 2 ppm per year thereafter.
- 4.3.4.1 Frequency Aging Duration Option. By customer request, the Aging test may be terminated after 15 days if the measured aging rate is less than half of the specified aging rate. This is a common method of expediting 30-Day Aging without incurring risk to the hardware and used quite successfully for numerous customers. It is based on the 'least squares fit' determinations of MIL-PRF-55310 paragraph 4.8.35. The 'half the time/half the spec' limit is generally conservative as roughly 2/3 of a unit's Aging deviation occurs within that period of time. Vectron's automated aging systems take about 6 data points per day, so a lot of data is

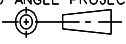
| | | | | | | |
|------------------|--------------------------------|---|--------------------------------------|----------------------------|------------------|-------------------|
| SIZE A | CODE IDENT NO. 00136 | THIRD ANGLE PROJECTION  | UNSPECIFIED TOLERANCES N/A | DWG NO. OS-68338 | REV. M | SHEET 5 |
|------------------|--------------------------------|---|--------------------------------------|----------------------------|------------------|-------------------|

available to do very accurate projections, much more data than what is required by MIL-PRF-55310. The delivered data would include the Aging plots projected to 30 days. If the units would not perform within that limit then they would continue to full 30 Day term. Please advise by purchase order text if this may be an acceptable option to exercise as it assists in Production Test planning.

- 4.3.5 Operating Characteristics. Symmetrical square wave limits are dependent on the device frequency and are in accordance with Tables 2 and 2A. Waveform measurement points and logic limits are in accordance with MIL-PRF-55310. Start-up time is 10.0 msec. maximum.
- 4.3.6 Output Load. Standard TTL (6 or 10) and ACMOS (10kΩ, 15pF) test loads are in accordance with MIL-PRF-55310.

5. QUALITY ASSURANCE PROVISIONS AND VERIFICATION

5.1 Verification and Test. Device lots shall be tested prior to delivery in accordance with the applicable Screening Option letter as stated by the 15th character of the part number. Table 5 tests are conducted in the order shown and annotated on the appropriate process travelers and data sheets of the governing test procedure. For devices that require Screening Options that include MIL-PRF-55310 Group A testing, the Post-Burn-In Electrical Test and the Group A Electrical Test are combined into one operation.

5.1.1 Screening Options. The Screening Options, by letter, are summarized as:

- A Modified MIL-PRF-38534 Class K
- B Modified MIL-PRF-55310 Class B Screening & Group A Quality Conformance Inspection (QCI)
- C Modified MIL-PRF-55310 Class S Screening & Group A QCI
- D Modified MIL-PRF-38534 Class K with Group B Aging
- E Modified MIL-PRF-55310 Class B Screening, Groups A & B QCI
- F Modified MIL-PRF-55310 Class S Screening, Groups A & B QCI
- G Modified MIL-PRF-55310 Class B Screening & Post Burn-in Nominal Electricals
- X Engineering Model (EM)

5.2 Optional Design, Test and Data Parameters. The following is a list of design, assembly, inspection and test options that can be selected or added by purchase order request.

- a. Design Pedigree (choose one as the 5th character in the part number):
 - (E) Enhanced Element Evaluation, 100krad Class S die, Premium Q Swept Quartz
 - (R) Hi-Rel design w/ 100krad Class S die, Premium Q Swept Quartz
 - (V) Hi-Rel design w/ 100krad Class S die, Non-Swept Quartz
 - (X) Hi-Rel design w/ Non-Swept Quartz, Class S die
 - (B) Hi-Rel design w/ Swept Quartz, Class B die
 - (C) Hi-Rel design w/ Non-Swept Quartz, Class B die
 - (D) Hi-Rel design w/ Non-Swept Quartz and commercial grade components
- b. Input Voltage, (A) for 5.0V, (B) for 3.3V as the 14th character
- c. Frequency-Temperature Slew Test

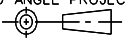
| | | | | | | |
|------------------|--------------------------------|---|--------------------------------------|----------------------------|------------------|-------------------|
| SIZE A | CODE IDENT NO. 00136 | THIRD ANGLE PROJECTION  | UNSPECIFIED TOLERANCES N/A | DWG NO. OS-68338 | REV. M | SHEET 6 |
|------------------|--------------------------------|---|--------------------------------------|----------------------------|------------------|-------------------|

- d. Radiographic Inspection
- e. Group C Inspection: In accordance with MIL-PRF-55310, Table VII (requires 8 destruct specimens)
- f. Group C Inspection: In accordance with MIL-PRF-38534, Table C-Xc, Condition PI (requires 8 destruct specimens – 5 pc. Life, 3 pc. RGA). Subgroup 1 fine leak test to be performed per MIL-STD-202, Method 112, Condition C.
- g. Internal Water-Vapor Content (RGA) samples and test performance
- h. MTBF Reliability Calculations
- i. Worst Case/Derating Analysis: MIL-HDBK-1547 with $T_j \text{ Max} = +105^\circ\text{C}$;
Derated Maximum Operating Temp = $T_j \text{ Max} - \Delta T_j$
- j. Deliverable Process Identification Documentation (PID)
- k. Customer Source Inspection (pre-crystal mount pre-cap, post-crystal mount pre-cap and final). Due to components being mounted underneath the crystal blank, the following model numbers should be considered for pre-crystal mount pre-cap inspection: 1103, 1109, 1115, 1116, 1117, 1119 and 1157.
- l. Destruct Physical Analysis (DPA): MIL-STD-1580 with exceptions as specified in Vectron DOC203982.
- m. Qualification: In accordance with MIL-PRF-55310, Table IV (requires 11 destruct specimens).
- n. Pre-cap photographs

5.2.1 NASA EEE-INST-002. A combination of Design Pedigree E or R, Option F Screening, Group C Inspection in accordance with Table VII of MIL-PRF-55310 and RGA, meet the requirements of Level 1 device reliability. A combination of Design Pedigree B, Option E Screening, Radiographic Inspection, Group C Inspection in accordance with Table VII of MIL-PRF-55310 and RGA, meet the requirements of Level 2 device reliability.

5.3 Test Conditions. Unless otherwise stated herein, inspections are performed in accordance with those specified in MIL-PRF-55310 and MIL-PRF-38534, in that order. Process travelers identify the applicable methods, conditions and procedures to be used. Examples of electrical test procedures that correspond to MIL-PRF-55310 requirements are shown in Table 3.

5.4 Special Test and Description.

5.4.1 Frequency-Temperature Slew. Frequency-Temperature Slew Test has been developed as an indicator of higher than normal internal water vapor content. The incremental temperature sweep from $+125^\circ\text{C}$ to -55°C and back to $+125^\circ\text{C}$ records output frequency fluctuations emulating the mass loading of moisture deposited on the crystal blank surface. Though not replacing a customer's internal water-vapor content (RGA) requirement, confidence is increased without destructively testing otherwise good devices.

5.5 Deliverable Data. The manufacturer supplies the following data, as a minimum, with each lot of devices:

- a. Completed assembly and screening lot travelers, including rework history and Certificate of Conformance.
- b. Electrical test variables data, identified by unique serial number.

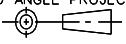
| | | | | | | |
|------------------|--------------------------------|---|--------------------------------------|----------------------------|------------------|-------------------|
| SIZE A | CODE IDENT NO. 00136 | THIRD ANGLE PROJECTION  | UNSPECIFIED TOLERANCES N/A | DWG NO. OS-68338 | REV. M | SHEET 7 |
|------------------|--------------------------------|---|--------------------------------------|----------------------------|------------------|-------------------|

- c. Frequency-Temperature Slew plots, Radiographic films, Group C data and RGA data as required by purchase order.
- d. Traceability, component LAT, enclosure LAT and RLAT (if specifically requested on the purchase order).

5.6 Discrepant Material. All MRB authority resides with the procuring activity.

5.7 Failure Analysis. Any catastrophic failure (no clocking, no current) at Post Burn-In or after will be evaluated for root cause. The customer will be notified after occurrence and upon completion of the evaluation.

6. PREPARATION FOR DELIVERY

6.1 Packaging. Devices will be packaged in a manner that prevents handling and transit damage during shipping. Devices will be handled in accordance with MIL-STD-1686 for Class 1 devices.

7. ORDERING INFORMATION

7.1 Ordering Part Number. The ordering part number is made up of an alphanumeric series of 15 characters. Design-affected product options, identified by the parenthetic letter on the Optional Parameters list (§ 5.2a and b), are included within the device part number.

The Part Number breakdown is described as:

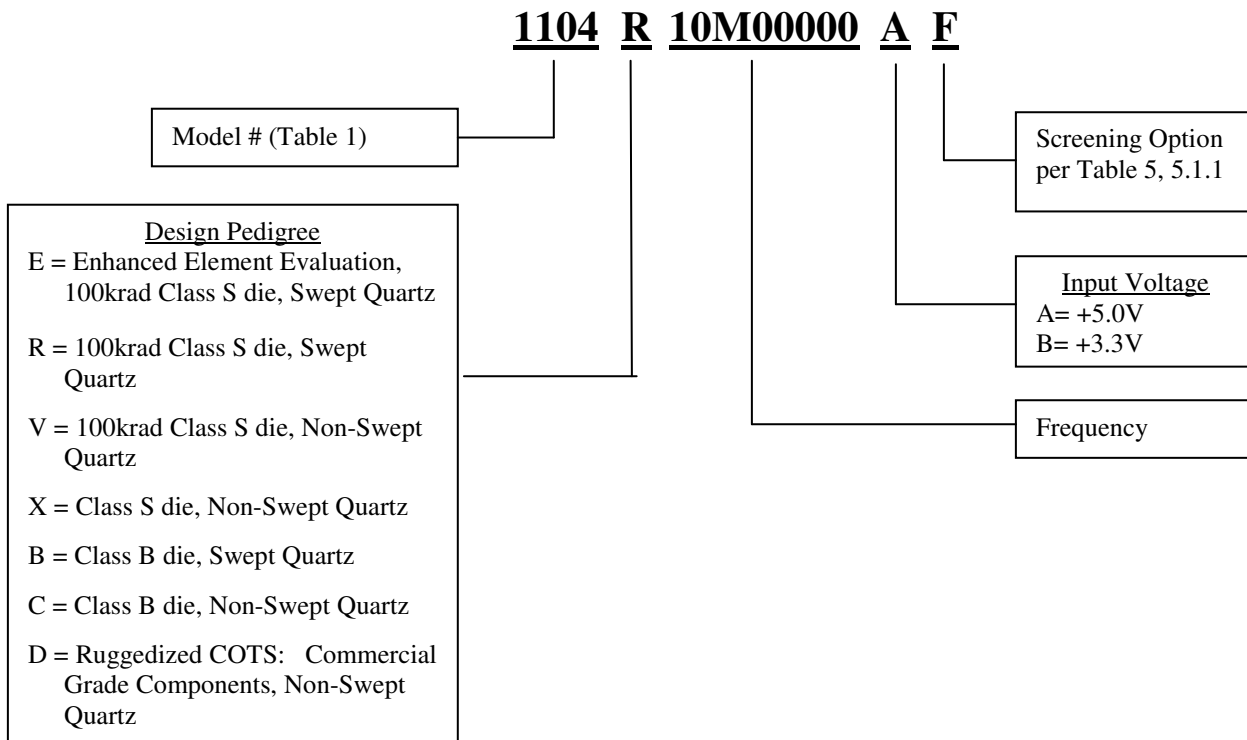

| | | | | | | |
|------------------|--------------------------------|----------------------------|--------------------------------------|----------------------------|------------------|-------------------|
| SIZE A | CODE IDENT NO. 00136 | THIRD ANGLE PROJECTION | UNSPECIFIED TOLERANCES N/A | DWG NO. OS-68338 | REV. M | SHEET 8 |
|------------------|--------------------------------|----------------------------|--------------------------------------|----------------------------|------------------|-------------------|

- 7.1.1 Model Number. The device model number is the four (4) digit number assigned to a corresponding package and output combination per Table 1.
- 7.1.2 Design Pedigree. Class S variants correspond to either letter “E”, “R”, “V” or “X” and are described in paragraph 5.2a. Class B variants correspond to either letter “B” or “C” and are described in paragraph 5.2a. Ruggedized COTS, using commercial grade components, corresponds to letter “D”.
- 7.1.2.1 Input Voltage. Voltage is the 14th character, letters “A” representing +5.0V and “B” for +3.3V.
- 7.1.3 Output Frequency. The nominal output frequency is expressed in the format as specified in MIL-PRF-55310 utilizing eight (8) characters.
- 7.1.4 Screening Options. The 15th character is the Screening Option (letter A thru G or X) selected from Table 5.
- 7.2 Optional Design, Test and Data Parameters. Test and documentation requirements above that of the standard high reliability model shall be specified by separate purchase order line items (as listed in ¶ 5.2c thru n).

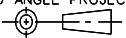
| | | | | | | |
|------------------|--------------------------------|---|--------------------------------------|----------------------------|------------------|-------------------|
| SIZE A | CODE IDENT NO. 00136 | THIRD ANGLE PROJECTION  | UNSPECIFIED TOLERANCES N/A | DWG NO. OS-68338 | REV. M | SHEET 9 |
|------------------|--------------------------------|---|--------------------------------------|----------------------------|------------------|-------------------|

| HI-REL STANDARD MODEL # | PACKAGE | OUTPUT, Square Wave | PIN I/O <u>1/</u> | | | | MECHANICAL OUTLINE |
|-------------------------------|------------------|---------------------------|-------------------|-----|--------------|------------------|-----------------------|
| | | | Vcc | Out | Gnd/ Case | E/D <u>2/</u> | |
| 1101 | 12 Lead Flatpack | ACMOS | 12 | 7 | 6 | na | FIGURE 1 |
| 1102 | 14 Lead Flatpack | ACMOS | 14 | 8 | 7 | na | FIGURE 2 |
| 1103 | 16 Lead Flatpack | ACMOS | 8 | 10 | 9 | na | FIGURE 3 |
| 1104 | 20 Lead Flatpack | ACMOS | 13, 20 | 11 | 10 | na | FIGURE 5 |
| 1105 | 14 Pin DIP | ACMOS | 14 | 8 | 7 | na | FIGURE 6 |
| 1115 | 4 pin ½ DIP | ACMOS | 8 | 5 | 4 | na | FIGURE 4 |
| 1116 | J-lead SMT | ACMOS | 4 | 3 | 2 | 1 | FIGURE 7 |
| 1157 <u>3/</u> | 4 pad 5 x 7mm | ACMOS | 4 | 3 | 2 | 1 | FIGURE 8 |
| 1119 <u>4/</u> | 16 Lead Flatpack | ACMOS | 8 | 10 | 9 | na | FIGURE 9 |
| 1120 <u>4/</u> | 20 Lead Flatpack | ACMOS | 13, 20 | 11 | 10 | na | FIGURE 10 |
| 1121 <u>4/</u> | 12 Lead Flatpack | ACMOS | 12 | 7 | 6 | na | FIGURE 11 |
| 1122 <u>4/</u> | 14 Lead Flatpack | ACMOS | 14 | 8 | 7 | na | FIGURE 12 |
| 1107 | 12 Lead Flatpack | TTL | 12 | 7 | 6 | na | FIGURE 1 |
| 1108 | 14 Lead Flatpack | TTL | 14 | 8 | 7 | na | FIGURE 2 |
| 1109 | 16 Lead Flatpack | TTL | 8 | 10 | 9 | na | FIGURE 3 |
| 1110 | 20 Lead Flatpack | TTL | 13, 20 | 11 | 10 | na | FIGURE 5 |
| 1111 | 14 Pin DIP | TTL | 14 | 8 | 7 | na | FIGURE 6 |
| 1117 | J-lead SMT | TTL | 4 | 3 | 2 | 1 | FIGURE 7 |

1/. All unassigned pins have no internal connections or ties.

2/. A logic “1” (>+2.0V) or open on pin 1 will enable the output. A logic “0” (<+0.8V) will disable the output.

3/. Model 1157 replaces previous Model 1118.

4/. Models 1119 through 1122 are lead formed versions of Models 1101 through 1104. See Appendix A for recommended land patterns.

TABLE 1 - Item Identification and Package Outline

| | | | | | | |
|------------------|--------------------------------|---|--------------------------------------|----------------------------|------------------|--------------------|
| SIZE A | CODE IDENT NO. 00136 | THIRD ANGLE PROJECTION  | UNSPECIFIED TOLERANCES N/A | DWG NO. OS-68338 | REV. M | SHEET 10 |
|------------------|--------------------------------|---|--------------------------------------|----------------------------|------------------|--------------------|

| Frequency Range @ +5V Operation: 0.35 MHz to 100.0 MHz | | | | | |
|---|-----------------------------|--------|---------------------------------------|--------------------------|----------------------------|
| Frequency Range @ +3.3V Operation: 0.35 MHz to 100.0 MHz | | | | | |
| Temperature Range: -55°C to +125°C | | | | | |
| Frequency Tolerance, Initial Accuracy @ +23°C: ±15 ppm max. | | | | | |
| Frequency-Temperature Stability from +23°C ref.: ±50 ppm max. | | | | | |
| Frequency-Voltage Tolerance: ±4 ppm max. (Vcc ±10%) | | | | | |
| Frequency Aging: ±1.5 ppm max. 1 st 30 days, ±5 ppm max. Year 1, ±2 ppm max. Year 2+ | | | | | |
| Start-up Time: 10.0 ms max. | | | | | |
| Frequency Range (MHz) <u>3/</u> | Current (mA) (max. no load) | | Rise / Fall Times <u>1/</u> (ns max.) | Duty Cycle <u>1/</u> (%) | Fan-out (if TTL) <u>2/</u> |
| | +5.5V <u>4/</u> | +3.63V | | | |
| 0.35 - 4.0 | 10 | 6 | 6 | 45 to 55 | 10 |
| 4.0 – 12.0 | 15 | 8 | 5 | 45 to 55 | 10 |
| >12.0 – 24.0 | 15 | 10 | 5 | 40 to 60 | 10 |
| >24.0 – 40.0 | 20 | 15 | 5 | 40 to 60 | 6 |
| >40.0 – 65.0 | 35 | 20 | 5 | 40 to 60 | 6 |
| >65.0 – 85.0 | 45 | 25 | 3 | 40 to 60 | 6 |
| >85.0 – 100 | 55 | 30 | 3 | 40 to 60 | 6 |

1/. Waveform measurement points and logic limits are in accordance with MIL-PRF-55310.

2/. For +3.3V TTL option, R_L=160Ω for 10 TTL loads and R_L=270Ω for 6 TTL loads.

3/. Exception: Model 1157 lower frequency limit is 1.50 MHz.

4/. For Model 1157 with Vcc = +5V and frequencies >40MHz, add 5mA to the maximum load current.

TABLE 2 - Electrical Performance Characteristics

| OPERATION LISTING | REQUIREMENTS AND CONDITIONS | VECTRON TEST PROCEDURE |
|---------------------------------|------------------------------|------------------------|
| @ all Electrical Tests | | |
| Input Current (no load) | MIL-PRF-55310, Para 4.8.5.1 | GR-51681 |
| Initial Accuracy @ Ref. Temp. | MIL-PRF-55310, Para 4.8.6 | GR-51596 |
| Output Logic Voltage Levels | MIL-PRF-55310, Para 4.8.21.3 | GR-51597 |
| Rise and Fall Times | MIL-PRF-55310, Para 4.8.22 | GR-51599 |
| Duty Cycle | MIL-PRF-55310, Para 4.8.23 | GR-51601 |
| @ Post Burn-In Electrical only | | |
| Overvoltage Survivability | MIL-PRF-55310, Para 4.8.4 | GR-37269 |
| Initial Freq. – Temp. Accuracy | MIL-PRF-55310, Para 4.8.10.1 | DOC005199 |
| Freq. – Voltage Tolerance | MIL-PRF-55310, Para 4.8.14 | DOC005199 |
| Start-up Time (fast/slow start) | MIL-PRF-55310, Para 4.8.29 | GR-61352 |

TABLE 3 - Electrical Test Parameters

| | | | | | | |
|------------------|--------------------------------|---|--------------------------------------|----------------------------|------------------|--------------------|
| SIZE A | CODE IDENT NO. 00136 | THIRD ANGLE PROJECTION  | UNSPECIFIED TOLERANCES N/A | DWG NO. OS-68338 | REV. M | SHEET 11 |
|------------------|--------------------------------|---|--------------------------------------|----------------------------|------------------|--------------------|

| Model # | Typical Thermal Resistance Junction to Case θ_{jc} ($^{\circ}\text{C} / \text{W}$) | Δ Junction Temp. T_j ($^{\circ}\text{C}$ @ max. I_{cc}) | Typical Weight (Grams) |
|--------------------|---|---|---------------------------|
| 1101 / 1107 / 1121 | 17.32 | 5.24 | 3.0 |
| 1102 / 1108 / 1122 | 17.32 | 5.24 | 3.3 |
| 1103 / 1109 / 1119 | 17.20 | 5.20 | 1.4 |
| 1104 / 1110 / 1120 | 16.97 | 5.13 | 2.9 |
| 1105 / 1111 | 19.57 | 5.92 | 3.9 |
| 1115 | 20.22 | 6.12 | 2.2 |
| 1116 / 1117 | 17.91 | 5.42 | 1.2 |
| 1157 | 3.77 | 1.14 | 0.2 |

Maximum operating power = 302.5 mW per Table 2.

TABLE 4 - Typical Thermal Characteristics and Weight

| Frequency | $V_{cc}=+5.0\text{V}$ | | | $V_{cc}=+3.3\text{V}$ | | |
|-----------|----------------------------------|---|--------------------------------|----------------------------------|---|--------------------------------|
| | Period Jitter 1 sigma (ps) | Phase Jitter (12kHz to 20MHz) (ps) | Period Jitter pk-pk (ps) | Period Jitter 1 sigma (ps) | Phase Jitter (12kHz to 20MHz) (ps) | Period Jitter pk-pk (ps) |
| 1 MHz | 8.5 | 8.0 | 60 | 20 | 11.3 | 150 |
| 24 MHz | 6 | 0.22 | 48 | 10 | 0.33 | 85 |
| 40 MHz | 5 | 0.16 | 40 | 8 | 0.25 | 70 |
| 80 MHz | 5 | 0.08 | 40 | 6 | 0.14 | 45 |
| 100 MHz | 4 | 0.08 | 32 | 5 | 0.14 | 40 |

TABLE 4a – Typical Jitter Performance

Note: Period Jitter measured at +23C and Nominal Voltage using Wavecrest Model SIA-3000.

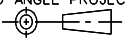
| | | | | | | |
|------------------|--------------------------------|---|--------------------------------------|----------------------------|------------------|--------------------|
| SIZE A | CODE IDENT NO. 00136 | THIRD ANGLE PROJECTION  | UNSPECIFIED TOLERANCES N/A | DWG NO. OS-68338 | REV. M | SHEET 12 |
|------------------|--------------------------------|---|--------------------------------------|----------------------------|------------------|--------------------|

| OPN. NO. | OPERATION LISTING | REQUIREMENTS AND CONDITIONS | Option A | Option B | Option C | Option D | Option E | Option F | Option G | Option X |
|----------|---|--|---------------|---------------|---------------|---------------|---------------|---------------|---------------|--------------|
| | SCREENING | MIL Class Similarity | K | B- | S- | K+ | B | S | | EM |
| | | | 100% | 100% | 100% | 100% | 100% | 100% | 100% | 100% |
| 1 | Non-Destruct Bond Pull | MIL-STD-883, Meth 2023 | X | NR | X | X | NR | X | NR | NR |
| 2 | Internal Visual | MIL-STD-883, Meth 2017 Class K, Meth 2032 Class K | X | X | X | X | X | X | X | X |
| 3 | Stabilization (Vacuum) Bake | MIL-STD-883, Meth 1008, Cond C, 150°C | X 48 hrs. | X 24 hrs. | X 48 hrs. | X 48 hrs. | X 24 hrs. | X 48 hrs. | X 24 hrs. | X 24 hrs. |
| 4 | Thermal Shock | MIL-STD-883, Meth 1011, Cond A | NR | NR | X | NR | NR | X | NR | NR |
| 5 | Temperature Cycle | MIL-STD-883, Meth 1010, Cond. B, 10 cycles min. | X | X | X | X | X | X | X | NR |
| 6 | Constant Acceleration | MIL-STD-883, Meth 2001, Cond A, Y1 plane only, 5000 g's | X | X | X | X | X | X | X | NR |
| 7 | Particle Impact Noise Detection | MIL-STD-883, Meth 2020, Cond B | X | X | X | X | X | X | NR | X |
| 8 | Electrical Testing, Pre Burn-In | Perform tests in Table 3. Nominal Vcc, nominal temperature | X | X | X | X | X | X | X | X |
| 9 | 1 st Burn-In | MIL-STD-883, Meth 1015, Condition B | X 160 hrs. | X 160 hrs. | X 240 hrs. | X 160 hrs. | X 160 hrs. | X 240 hrs. | X 160 hrs. | NR |
| 10 | Electrical Testing, Intermediate | Perform tests in Table 3. Nominal Vcc, nominal temperature | X | NR | NR | X | NR | NR | NR | NR |
| 11 | 2 nd Burn-In | MIL-STD-883, Meth 1015, Condition B | X 160 hrs. | NR | NR | X 160 hrs. | NR | NR | NR | NR |
| 12 | Freq-Temp Slew Test | Operating temp. range, frequency plotted at 1.0°C steps | AR | AR | AR | AR | AR | AR | NR | NR |
| 13 | Electrical Testing, Post Burn-In (Group A) | Perform tests in Table 3. Nominal Vcc & extremes, nominal temperature & extremes | X | X | X | X | X | X | X nom. Vcc | NR |
| 14 | Seal: Fine Leak | MIL-STD-202, Meth 112, Cond C 5 x 10 ⁻⁸ atm cc/sec max | X | X | X | X | X | X | X | X |
| 15 | Seal: Gross Leak | MIL-STD-202, Meth 112, Cond D | X | X | X | X | X | X | X | X |
| 16 | Radiographic Inspection | MIL-STD-883, Meth 2012 | X | AR | AR | X | AR | X | NR | NR |
| 17 | Solderability | MIL-STD-883, Meth 2003 | <u>1/</u> | <u>1/</u> | <u>1/</u> | <u>1/</u> | <u>1/</u> | <u>1/</u> | <u>1/</u> | NR |
| 18 | External Visual & Mechanical | MIL-STD-883, Meth 2009 | X <u>2/</u> | X <u>2/</u> | X <u>2/</u> | X <u>2/</u> | X <u>2/</u> | X <u>2/</u> | X <u>2/</u> | X <u>2/</u> |
| 19 | Aging, 30 Day <u>3/</u> (M55310 Group B) | MIL-PRF-55310, para. 4.8.35.1 | NR | NR | NR | X | 13 pcs. | X | NR | NR |

LEGEND: X = Required, NR = Not Required, AR = As Required

TABLE 5 - Test Matrix

1/ Performed at package LAT. Include LAT data sheet

2/ When specified, RGA samples will be removed from the lot after completion of this operation. Use of Screening failures require customer concurrence.

3/ By customer request, the Aging test may be terminated after 15 days if the measured aging rate is less than one-half the specified aging rate, as described in paragraph 4.3.4.1 herein. See the customer PO.

| | | | | | | |
|------------------|--------------------------------|---|--------------------------------------|----------------------------|------------------|--------------------|
| SIZE A | CODE IDENT NO. 00136 | THIRD ANGLE PROJECTION  | UNSPECIFIED TOLERANCES N/A | DWG NO. OS-68338 | REV. M | SHEET 13 |
|------------------|--------------------------------|---|--------------------------------------|----------------------------|------------------|--------------------|

| Subgroup | Class | Test | Mil-STD-883 | | Quantity (accept number) | Mil-PRF-38534 Reference Paragraph |
|----------|-------|--|----------------------|--|-----------------------------|---|
| | K | | Method | Condition | | |
| 1 | X | Element Electrical A. May perform at wafer level B. All failures shall be removed from the lot C. Perform at room ambient | | | 100% | C.3.3.1 |
| 2 | X | Element Visual | 2010 | | 100% | C.3.3.2 |
| 3 | X | Internal Visual | 2010 | | 10(0) or 22(0) | C.3.3.3 C.3.3.4.2 |
| 4 | X | Temperature Cycling | 1010 | C | 10(0) 22(0) | C.3.3.3 |
| | X | Mechanical Shock or Constant Acceleration | 2002 2001 | B, Y1 direction 3,000 G, Y1 direction | | |
| | X | Interim Electrical | | | | C.3.3.4.3 |
| | X | Burn-In | 1015 | 240 hours minimum at +125°C | | |
| | X | Post Burn-In Electrical | | | | C.3.3.4.3 |
| | X | Steady State Life | 1005 | | | |
| | X | Final Electrical | | | | C.3.3.4.3 |
| | 5 | X | Wire Bond Evaluation | 2011 | | |
| 6 | X | SEM | 2018 | | See method 2018 | C.3.3.6 |

Notes:

Subgroups 3, 4, & 5 shall be performed on a sample of 10 die if the wafer lot is from a QPL/QML line. If the die are from commercial wafer lots, then the sample size shall be 22 die.

TABLE 6 - MICROCIRCUIT ENHANCED ELEMENT EVALUATION

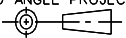
| | | | | | | |
|------------------|--------------------------------|---|--------------------------------------|----------------------------|------------------|--------------------|
| SIZE A | CODE IDENT NO. 00136 | THIRD ANGLE PROJECTION  | UNSPECIFIED TOLERANCES N/A | DWG NO. OS-68338 | REV. M | SHEET 14 |
|------------------|--------------------------------|---|--------------------------------------|----------------------------|------------------|--------------------|

| Parts Type | Test | Requirement Paragraph | Sample size | Allowable Reject(s) |
|--|---------|-----------------------|-------------|---------------------|
| Ceramic Capacitors | | | | |
| M55681 FRL S or M123 (chips) | N/A | N/A | N/A | N/A |
| Resistors | | | | |
| M55342 FRL R or S | N/A | N/A | N/A | N/A |
| Inductors (See Paragraph 4.1.2) | | | | |
| Custom closed magnetics | Group A | Mil-Std-981 | Mil-Std-981 | Mil-Std-981 |
| | Group B | Mil-Std-981 | Mil-Std-981 | Mil-Std-981 |
| <p>Magnetics, Closed Construction Leaded and Surface Mount (transformers, inductors, coils) (Note: Stacking magnetics shall be qualified and the effects of the long term performance of the hybrids verified. When stacking magnetics, a repeat of the thermal cycling plus electrical measurements as specified in Group A of Mil-Std-981. Design, workmanship and materials/processes shall conform to MIL-STD-981 requirements).</p> <p>Magnetics, Open Construction are unencapsulated and unpotted self-leaded parts consisting of magnet wire wound around a magnetic core. These parts are fully visually inspectable. Open construction magnetics shall be subjected to 100% electrical measurements and visual inspection per Mil-Std-981.</p> | | | | |

TABLE 7: PASSIVE COMPONENT ENHANCED ELEMENT EVALUATION

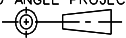
| | | | | | | |
|------------------|--------------------------------|---|--------------------------------------|----------------------------|------------------|--------------------|
| SIZE A | CODE IDENT NO. 00136 | THIRD ANGLE PROJECTION  | UNSPECIFIED TOLERANCES N/A | DWG NO. OS-68338 | REV. M | SHEET 15 |
|------------------|--------------------------------|---|--------------------------------------|----------------------------|------------------|--------------------|

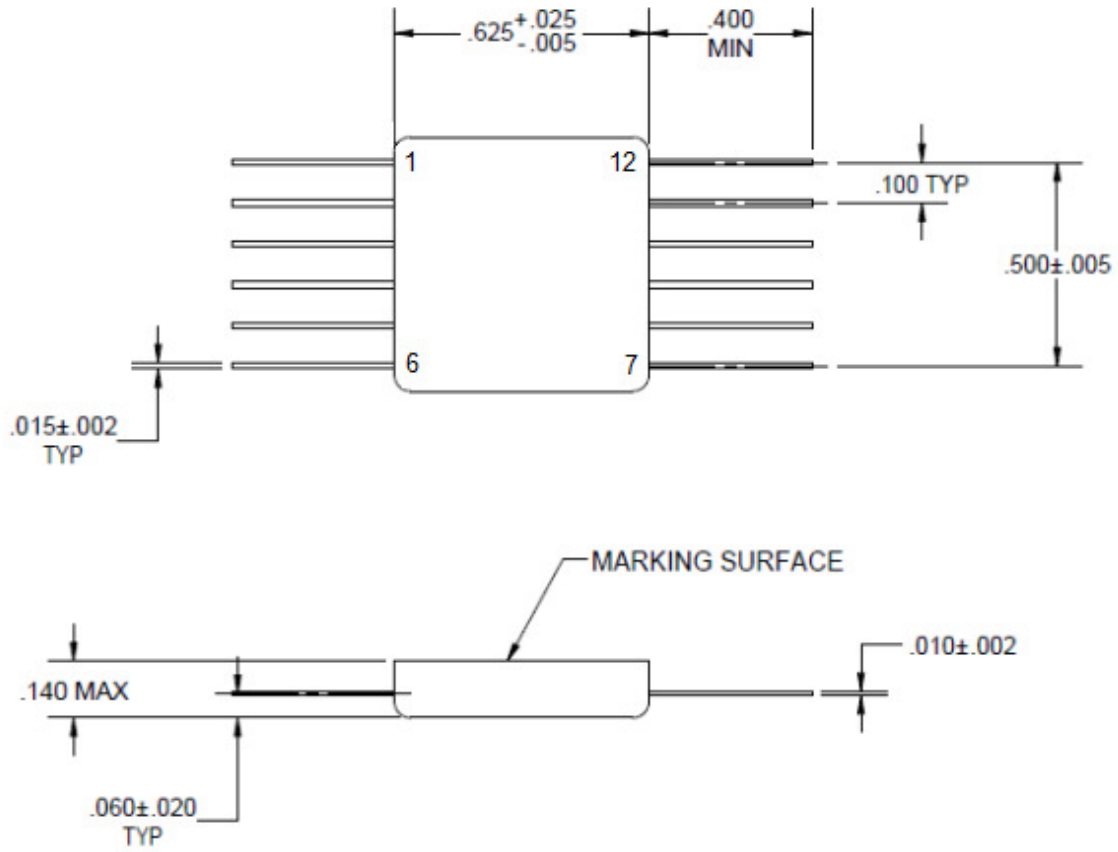
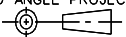

FIGURE 1
Models 1101 & 1107 Package Outline

| SIZE | CODE IDENT NO. | THIRD ANGLE PROJECTION | UNSPECIFIED TOLERANCES | DWG NO. | REV. | SHEET |
|------|----------------|---|------------------------|----------|------|-------|
| A | 00136 |  | N/A | OS-68338 | M | 16 |

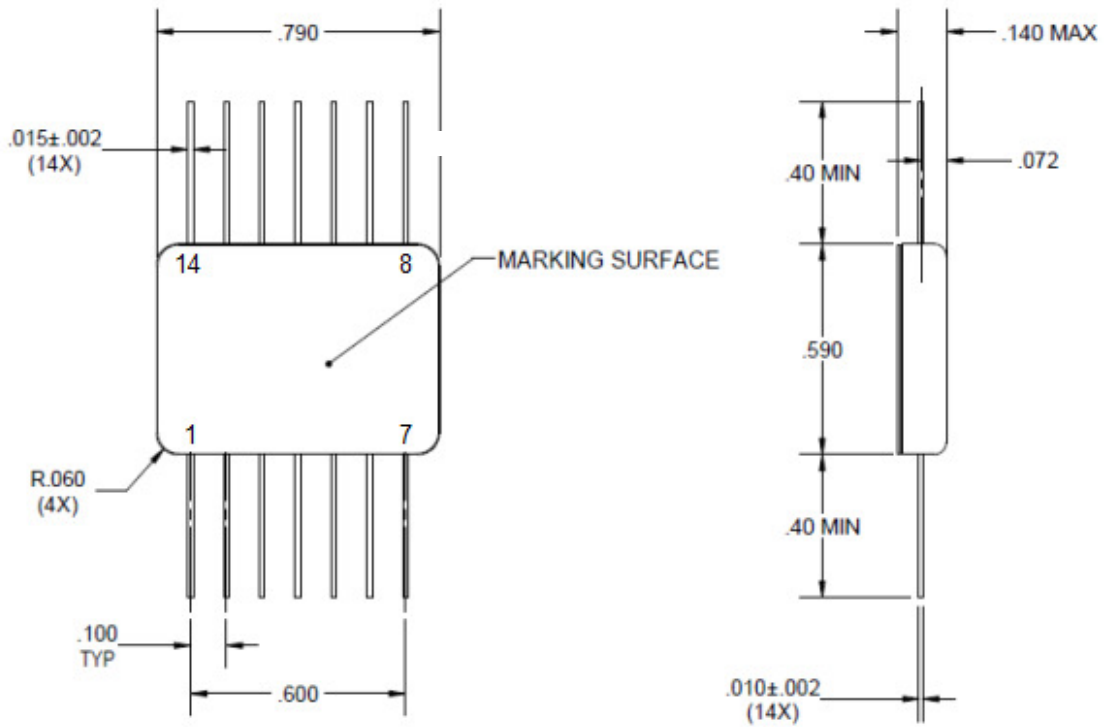
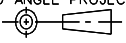

FIGURE 2
 Models 1102 & 1108 Package Outline
 Tolerances: Unspecified = ±0.010"

| SIZE | CODE IDENT NO. | THIRD ANGLE PROJECTION | UNSPECIFIED TOLERANCES | DWG NO. | REV. | SHEET |
|------|----------------|---|------------------------|----------|------|-------|
| A | 00136 |  | N/A | OS-68338 | M | 17 |

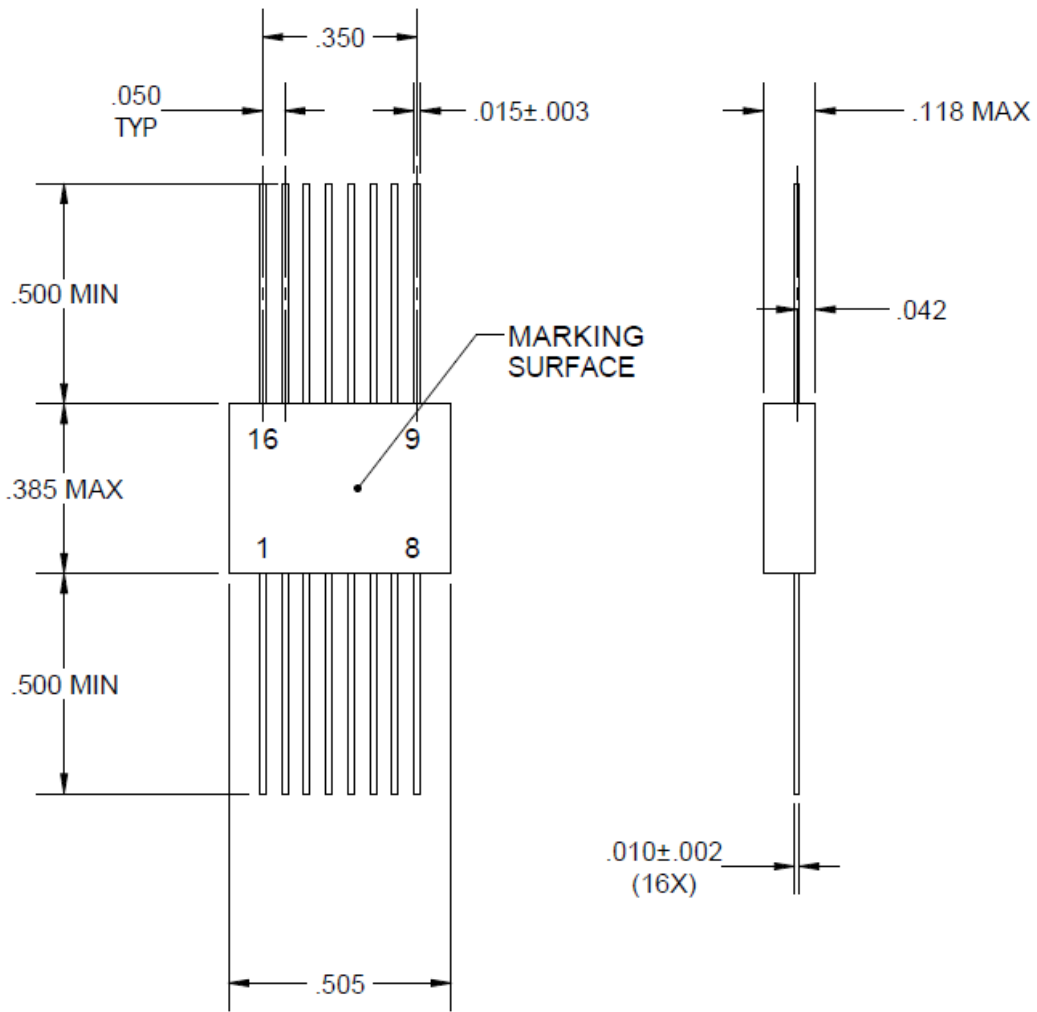
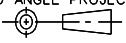

FIGURE 3
Models 1103 & 1109 Package Outline

| SIZE | CODE IDENT NO. | THIRD ANGLE PROJECTION | UNSPECIFIED TOLERANCES | DWG NO. | REV. | SHEET |
|------|----------------|---|------------------------|----------|------|-------|
| A | 00136 |  | N/A | OS-68338 | M | 18 |

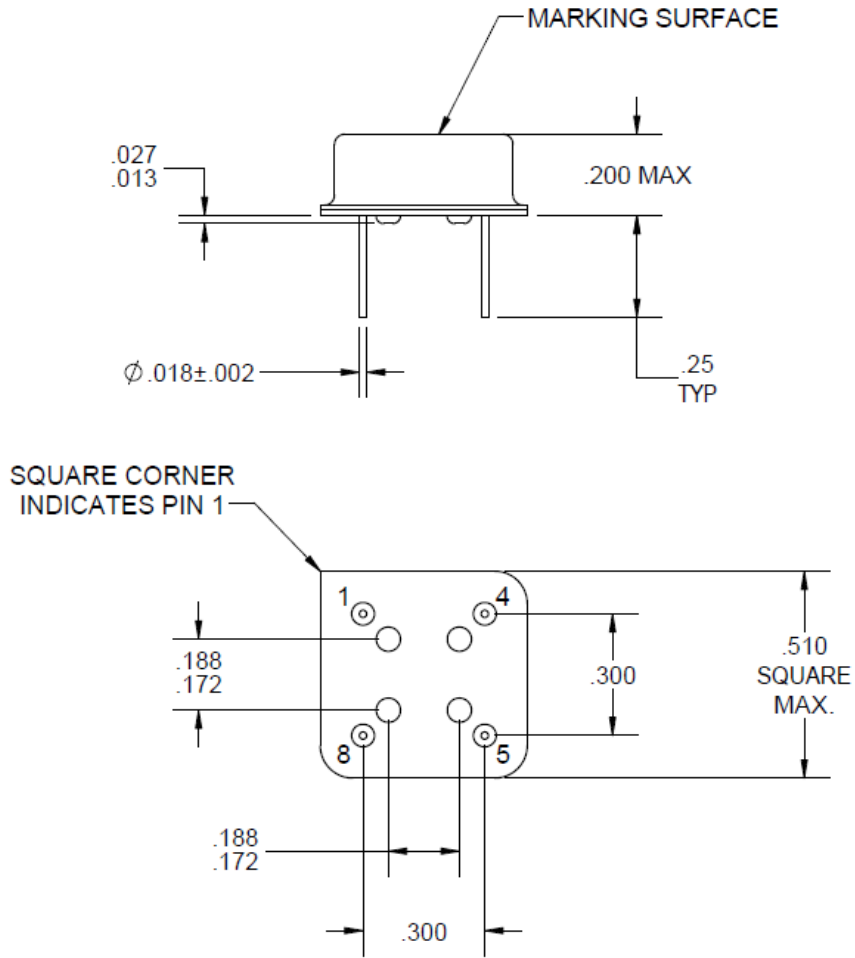
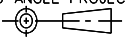

FIGURE 4
Model 1115 Package Outline

| SIZE | CODE IDENT NO. | THIRD ANGLE PROJECTION | UNSPECIFIED TOLERANCES | DWG NO. | REV. | SHEET |
|------|----------------|---|------------------------|----------|------|-------|
| A | 00136 |  | N/A | OS-68338 | M | 19 |

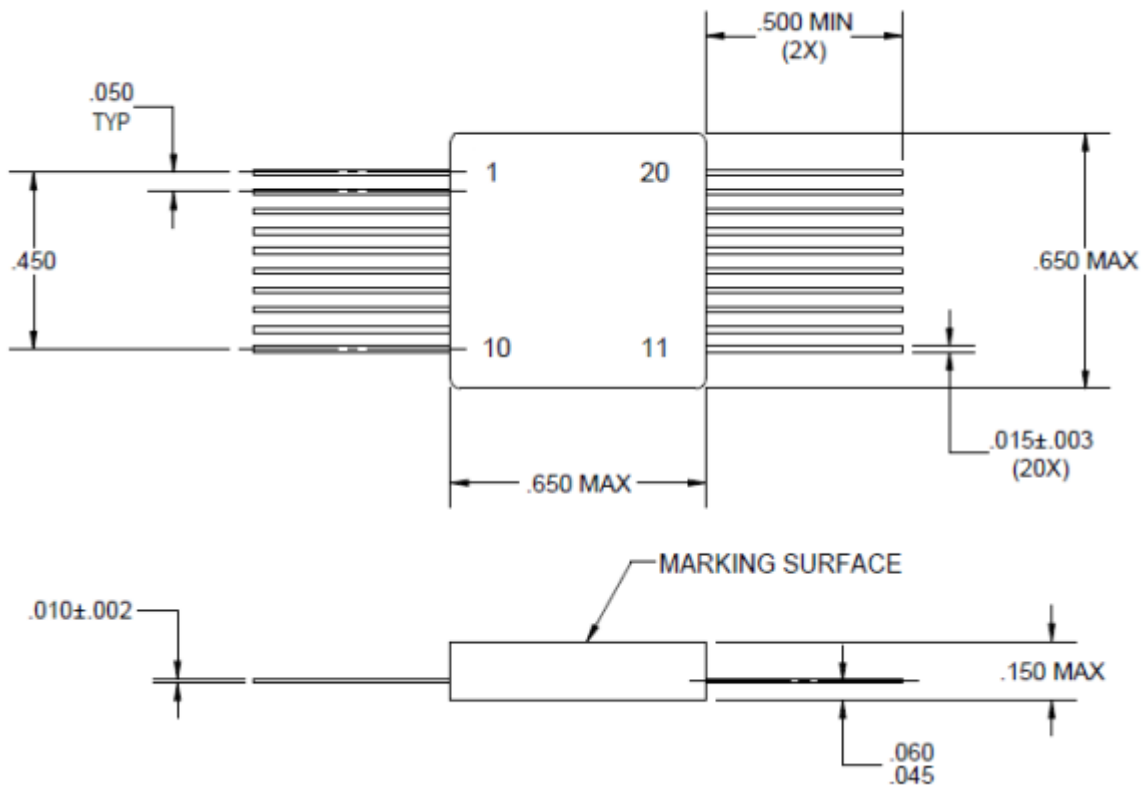
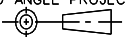

FIGURE 5
Model 1104 & 1110 Package Outline

| SIZE | CODE IDENT NO. | THIRD ANGLE PROJECTION | UNSPECIFIED TOLERANCES | DWG NO. | REV. | SHEET |
|------|----------------|---|------------------------|----------|------|-------|
| A | 00136 |  | N/A | OS-68338 | M | 20 |

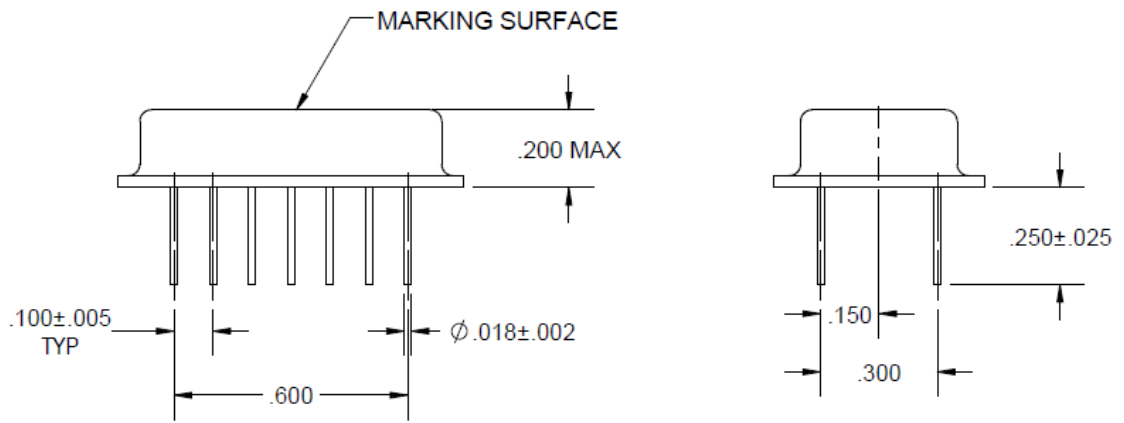
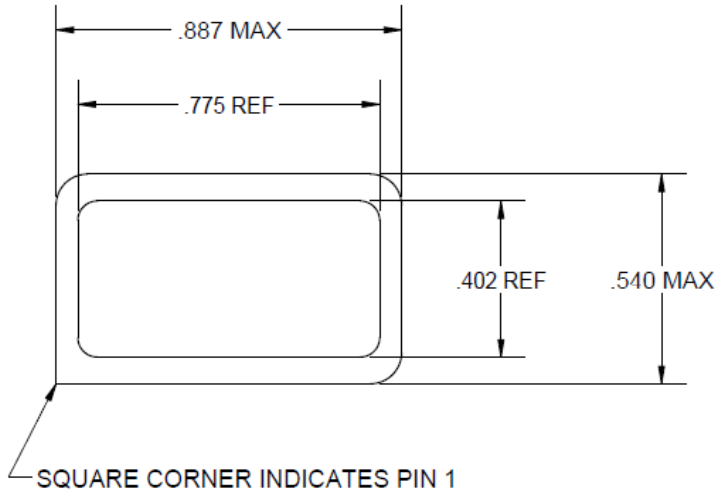
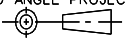

FIGURE 6
Model 1105 & 1111 Package Outline

| | | | | | | |
|------------------|--------------------------------|---|--------------------------------------|----------------------------|------------------|--------------------|
| SIZE A | CODE IDENT NO. 00136 | THIRD ANGLE PROJECTION  | UNSPECIFIED TOLERANCES N/A | DWG NO. OS-68338 | REV. M | SHEET 21 |
|------------------|--------------------------------|---|--------------------------------------|----------------------------|------------------|--------------------|

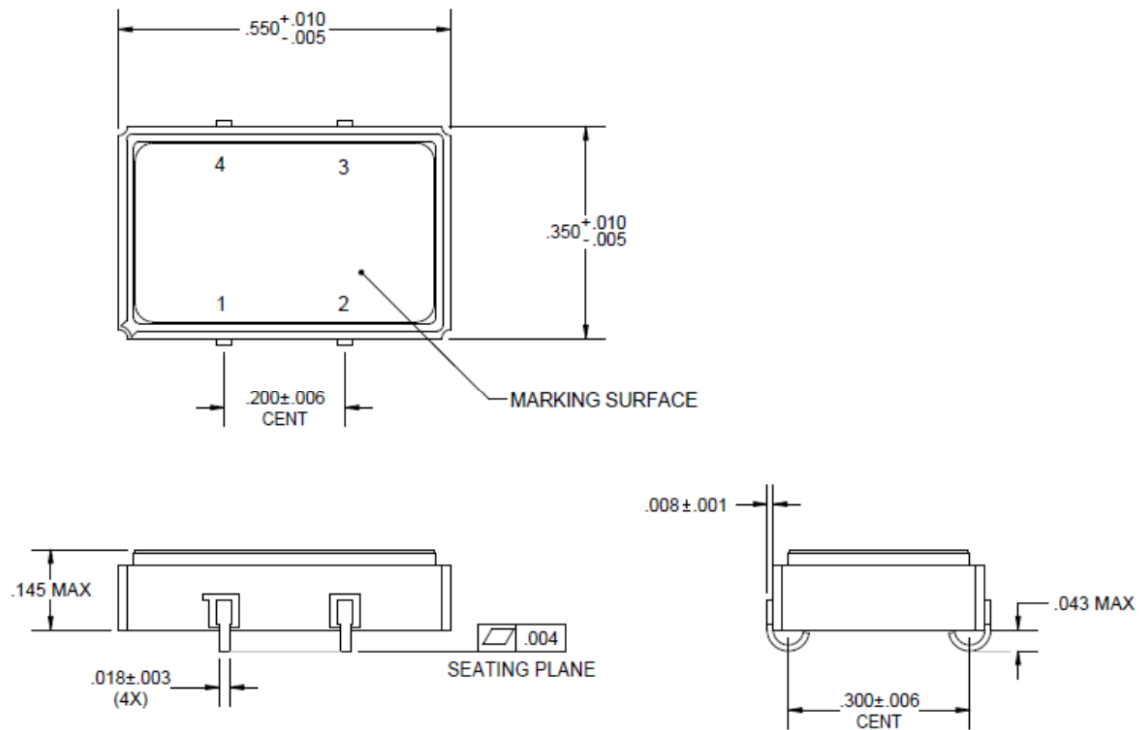
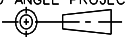

FIGURE 7
Model 1116 & 1117 Package Outline

| SIZE | CODE IDENT NO. | THIRD ANGLE PROJECTION | UNSPECIFIED TOLERANCES | DWG NO. | REV. | SHEET |
|------|----------------|---|------------------------|----------|------|-------|
| A | 00136 |  | N/A | OS-68338 | M | 22 |

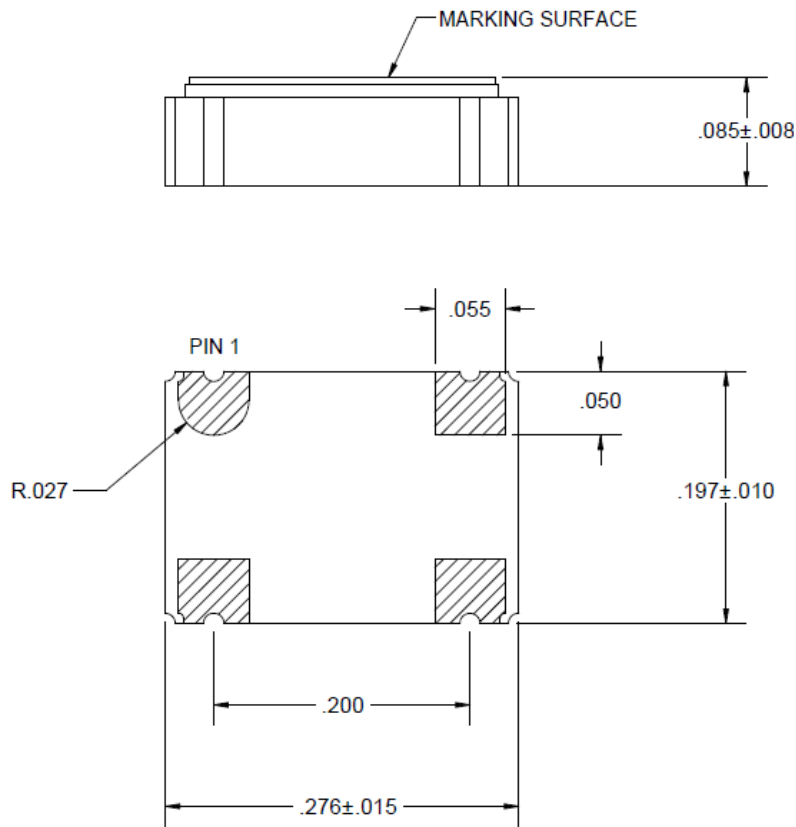
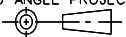

FIGURE 8
Model 1157 Package Outline

| | | | | | | |
|------------------|--------------------------------|---|--------------------------------------|----------------------------|------------------|--------------------|
| SIZE A | CODE IDENT NO. 00136 | THIRD ANGLE PROJECTION  | UNSPECIFIED TOLERANCES N/A | DWG NO. OS-68338 | REV. M | SHEET 23 |
|------------------|--------------------------------|---|--------------------------------------|----------------------------|------------------|--------------------|

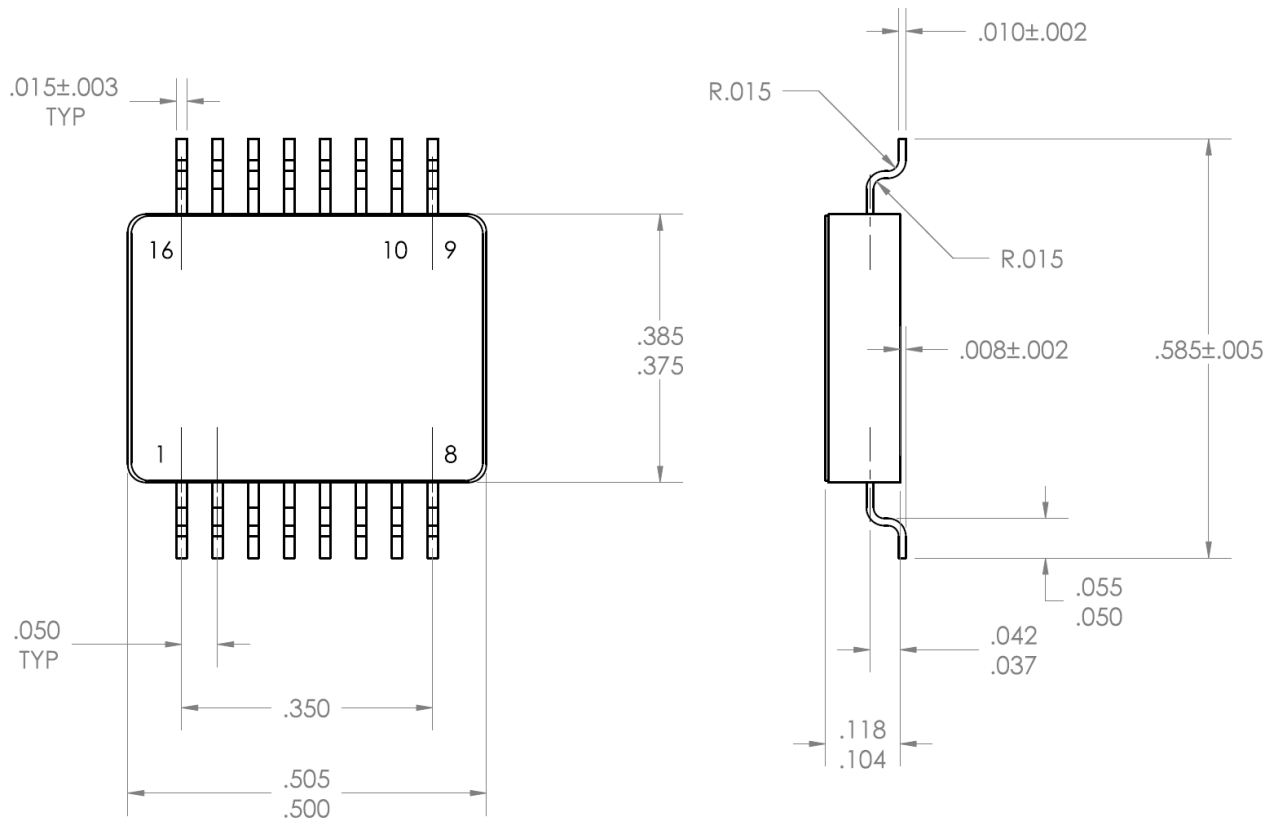

FIGURE 9
Model 1119 Package Outline

| | | | | | | |
|------------------|--------------------------------|---|--------------------------------------|----------------------------|------------------|--------------------|
| SIZE A | CODE IDENT NO. 00136 | THIRD ANGLE PROJECTION  | UNSPECIFIED TOLERANCES N/A | DWG NO. OS-68338 | REV. M | SHEET 24 |
|------------------|--------------------------------|---|--------------------------------------|----------------------------|------------------|--------------------|

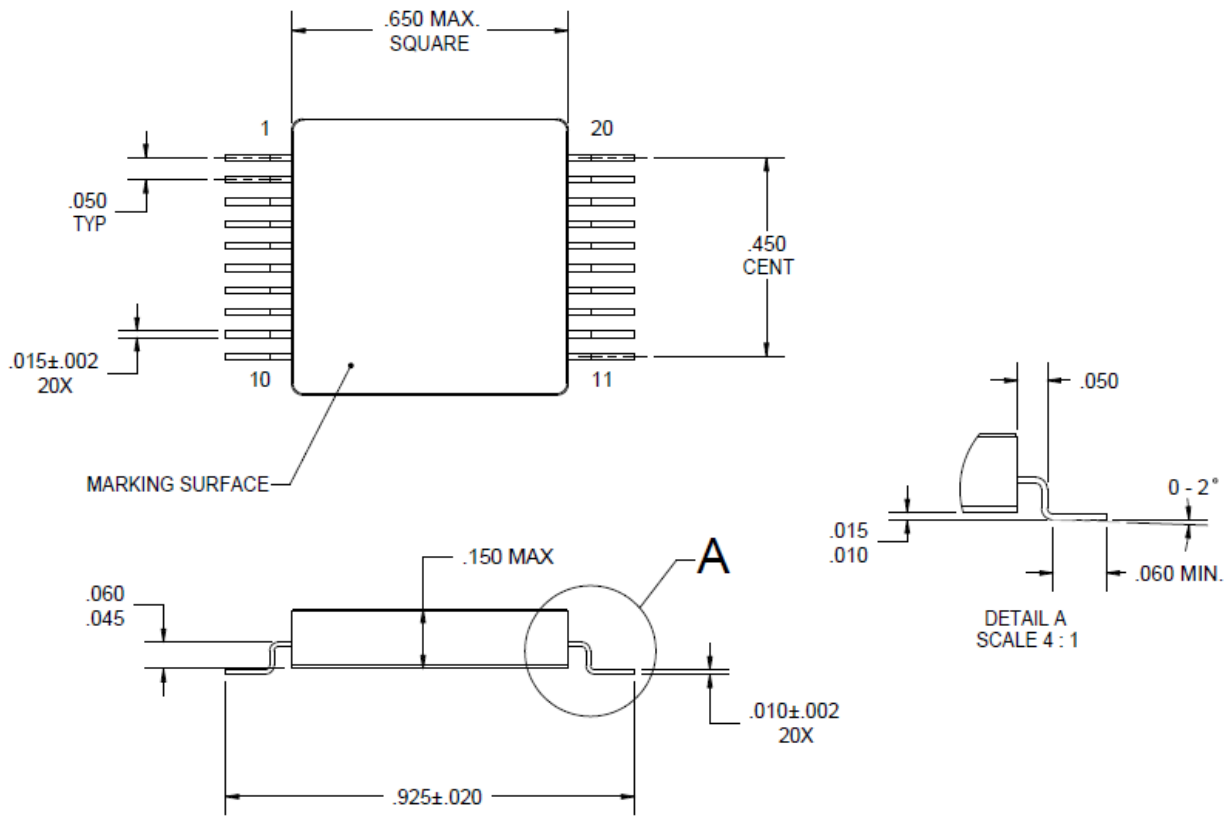
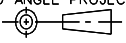

FIGURE 10
Model 1120 Package Outline

| SIZE | CODE IDENT NO. | THIRD ANGLE PROJECTION | UNSPECIFIED TOLERANCES | DWG NO. | REV. | SHEET |
|------|----------------|---|------------------------|----------|------|-------|
| A | 00136 |  | N/A | OS-68338 | M | 25 |

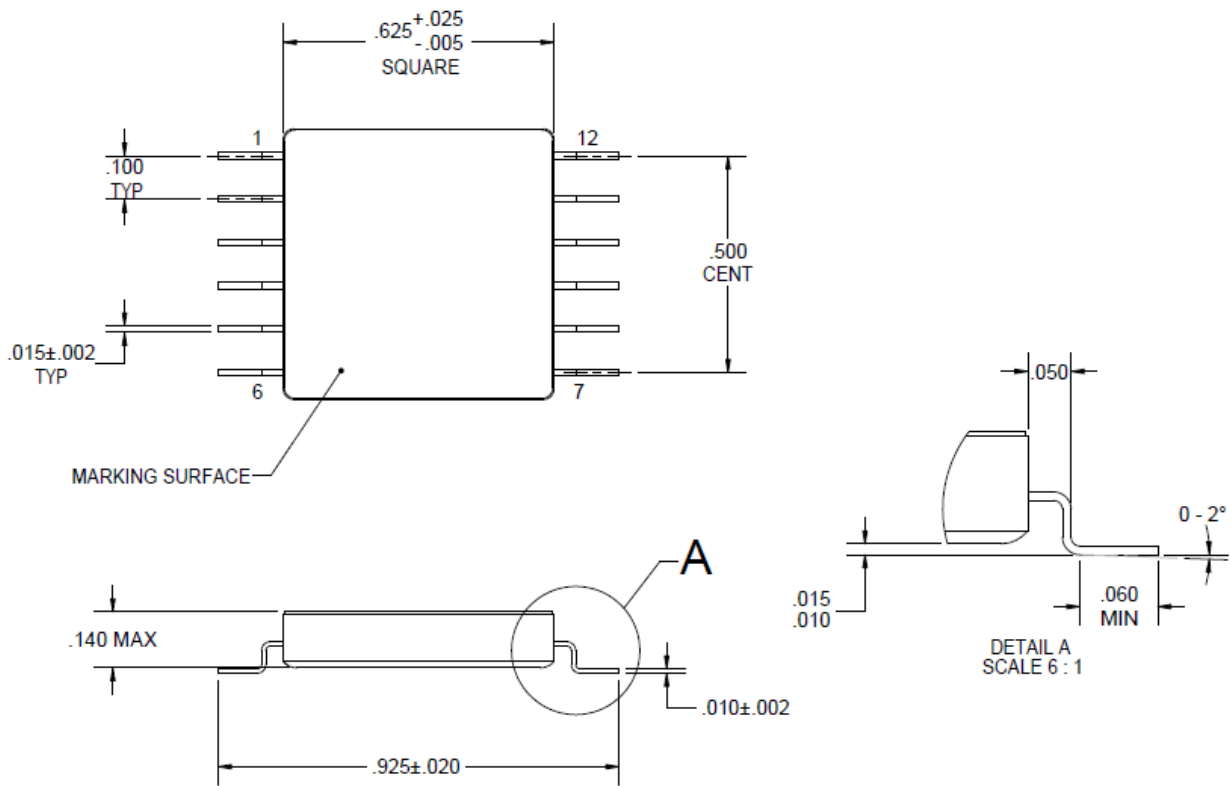
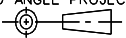

FIGURE 11
Model 1121 Package Outline

| SIZE | CODE IDENT NO. | THIRD ANGLE PROJECTION | UNSPECIFIED TOLERANCES | DWG NO. | REV. | SHEET |
|------|----------------|---|------------------------|----------|------|-------|
| A | 00136 |  | N/A | OS-68338 | M | 26 |

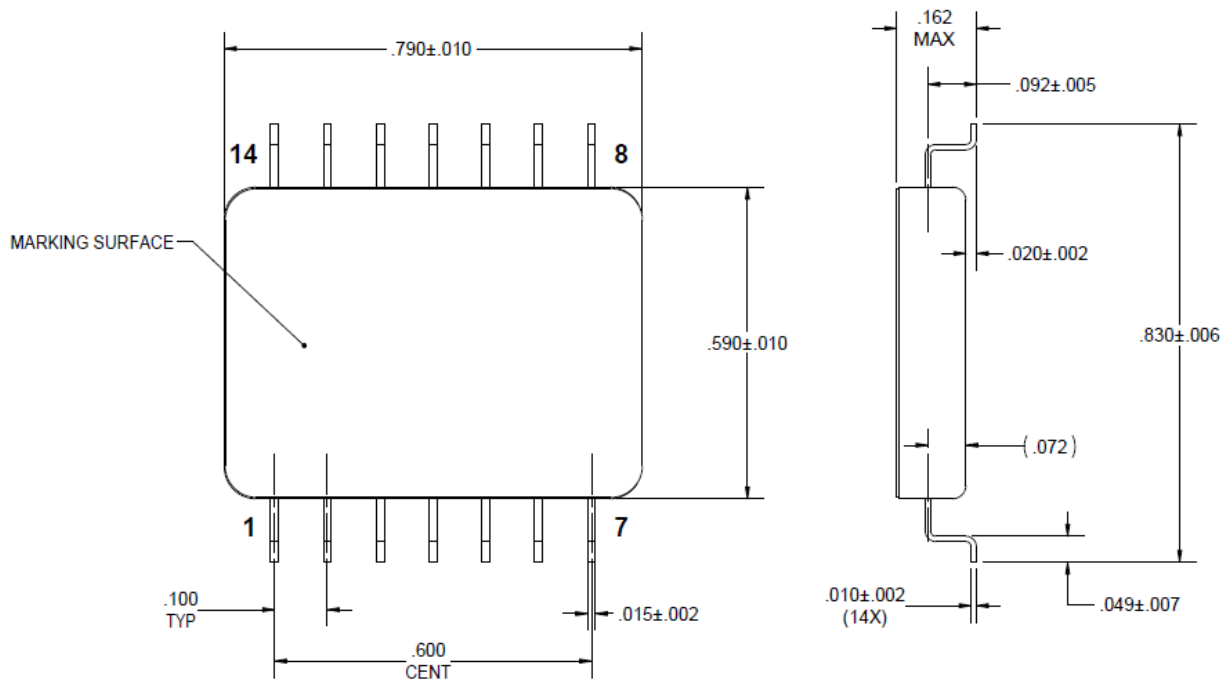
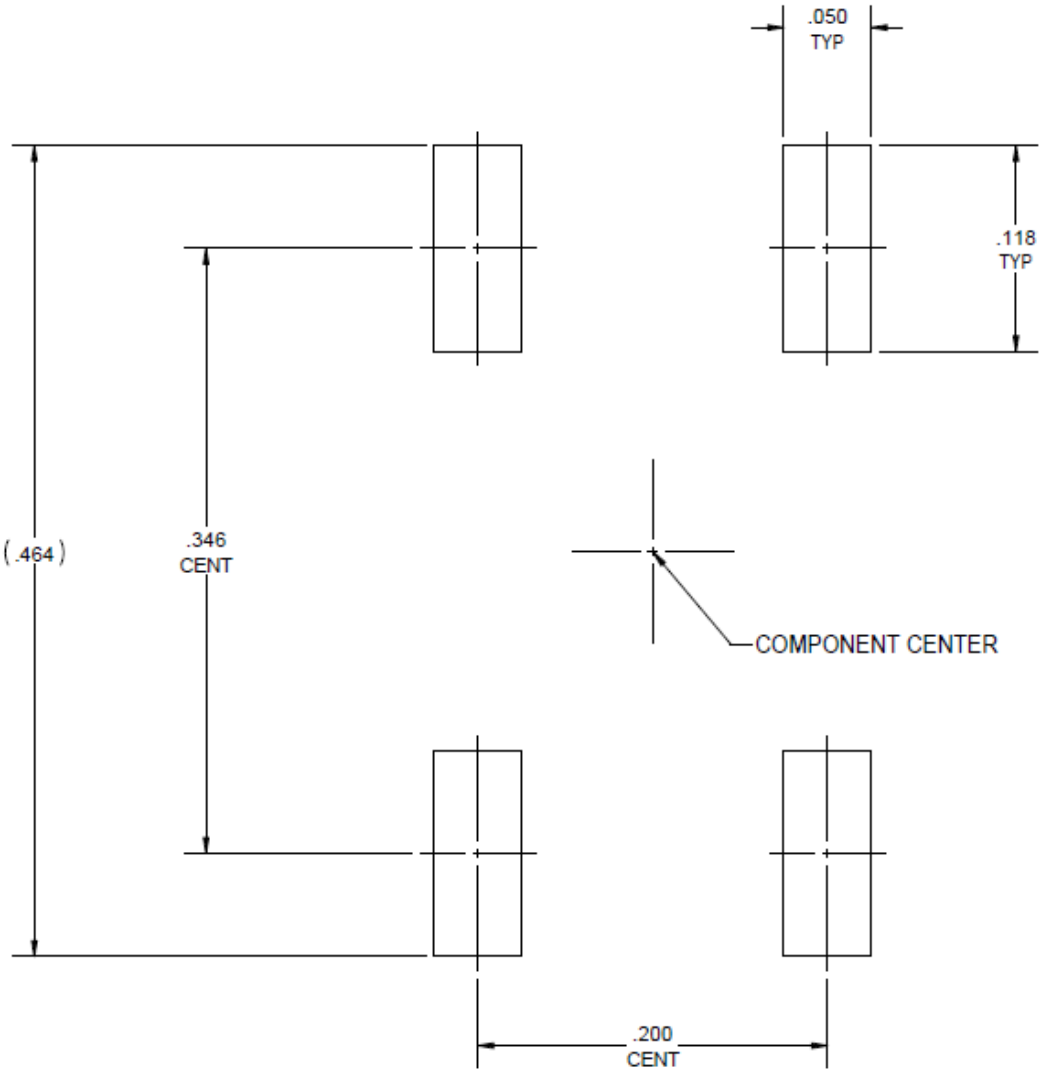

FIGURE 12
Model 1122 Package Outline

| | | | | | | |
|------------------|--------------------------------|---|--------------------------------------|----------------------------|------------------|--------------------|
| SIZE A | CODE IDENT NO. 00136 | THIRD ANGLE PROJECTION  | UNSPECIFIED TOLERANCES N/A | DWG NO. OS-68338 | REV. M | SHEET 27 |
|------------------|--------------------------------|---|--------------------------------------|----------------------------|------------------|--------------------|

APPENDIX A
Recommended Land Patterns

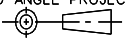

Model 1116 & 1117

| | | | | | | |
|------------------|--------------------------------|---|--------------------------------------|----------------------------|------------------|--------------------|
| SIZE A | CODE IDENT NO. 00136 | THIRD ANGLE PROJECTION  | UNSPECIFIED TOLERANCES N/A | DWG NO. OS-68338 | REV. M | SHEET 28 |
|------------------|--------------------------------|---|--------------------------------------|----------------------------|------------------|--------------------|

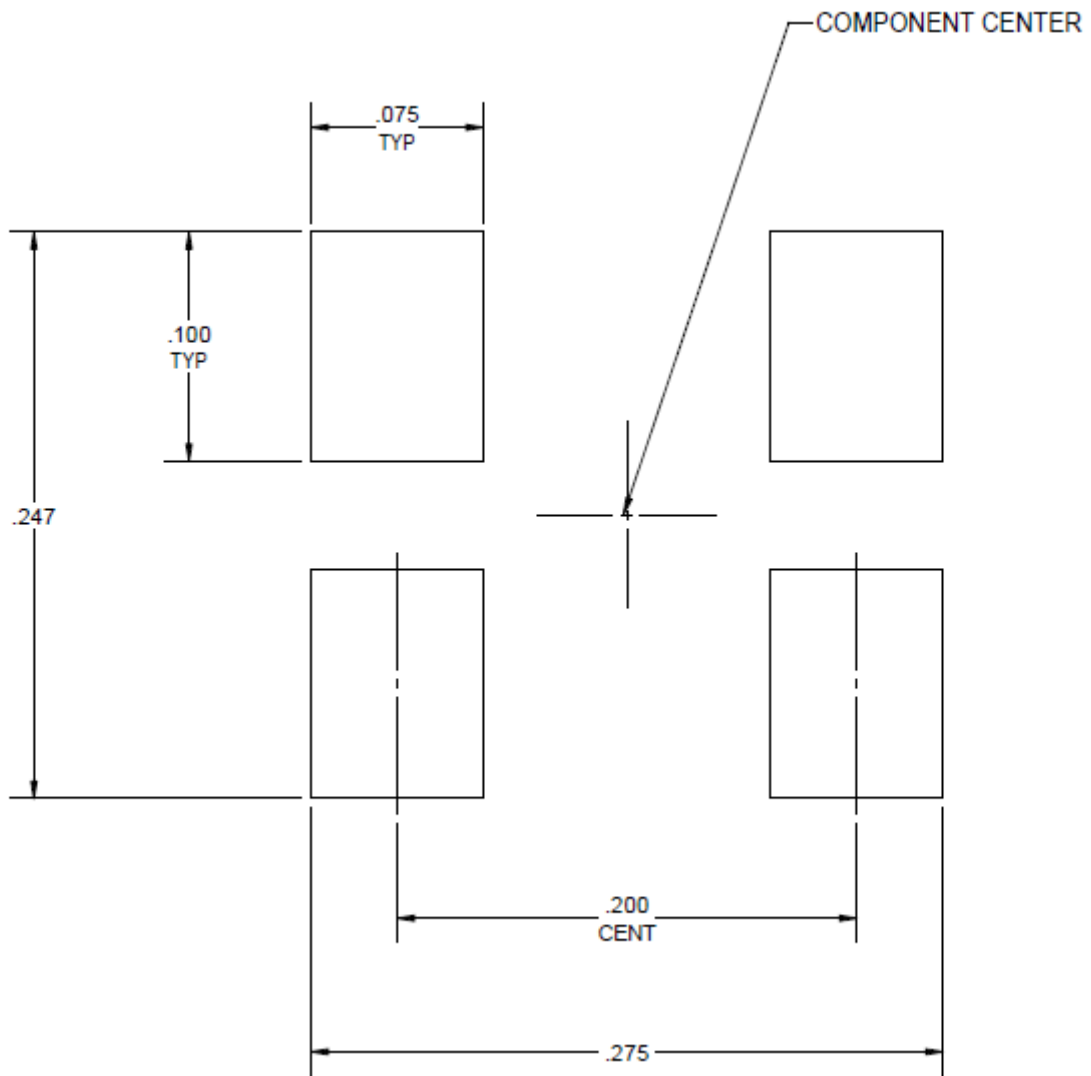

Model 1157

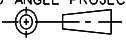
| | | | | | | |
|------------------|--------------------------------|---|--------------------------------------|----------------------------|------------------|--------------------|
| SIZE A | CODE IDENT NO. 00136 | THIRD ANGLE PROJECTION  | UNSPECIFIED TOLERANCES N/A | DWG NO. OS-68338 | REV. M | SHEET 29 |
|------------------|--------------------------------|---|--------------------------------------|----------------------------|------------------|--------------------|

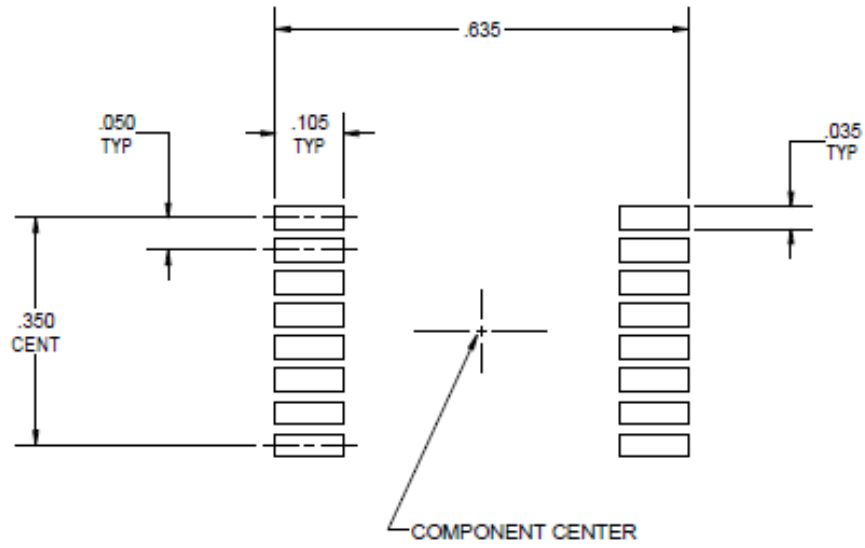

Model 1119

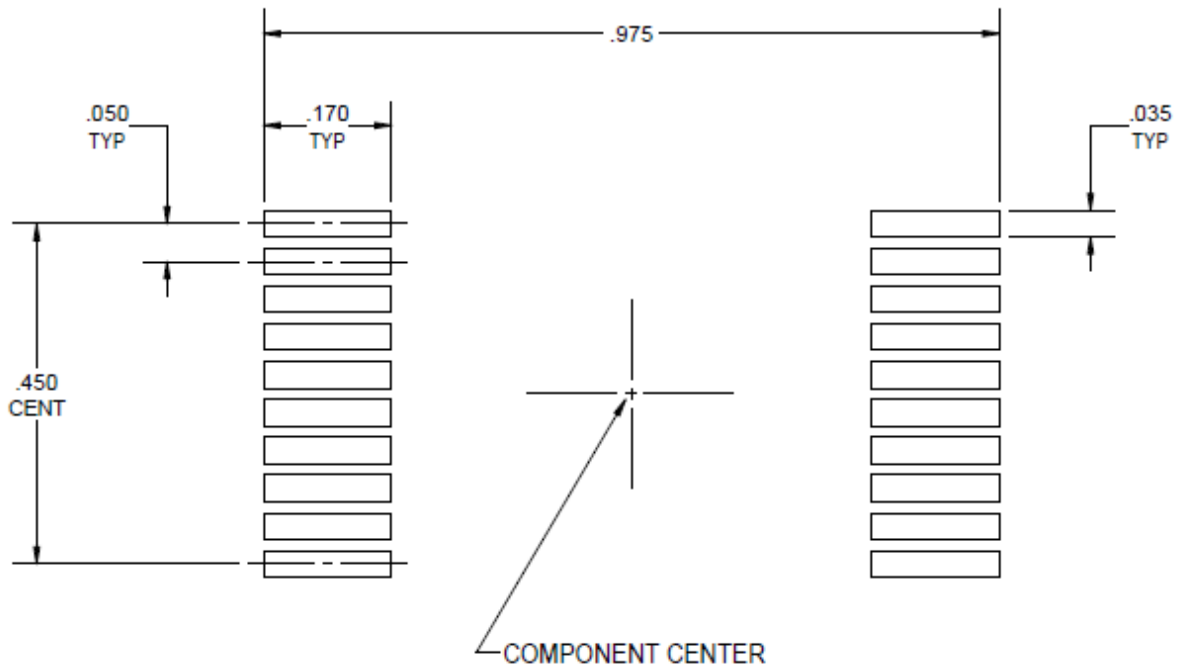

Model 1120

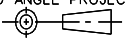
| SIZE | CODE IDENT NO. | THIRD ANGLE PROJECTION | UNSPECIFIED TOLERANCES | DWG NO. | REV. | SHEET |
|------|----------------|---|------------------------|----------|------|-------|
| A | 00136 |  | N/A | OS-68338 | M | 30 |

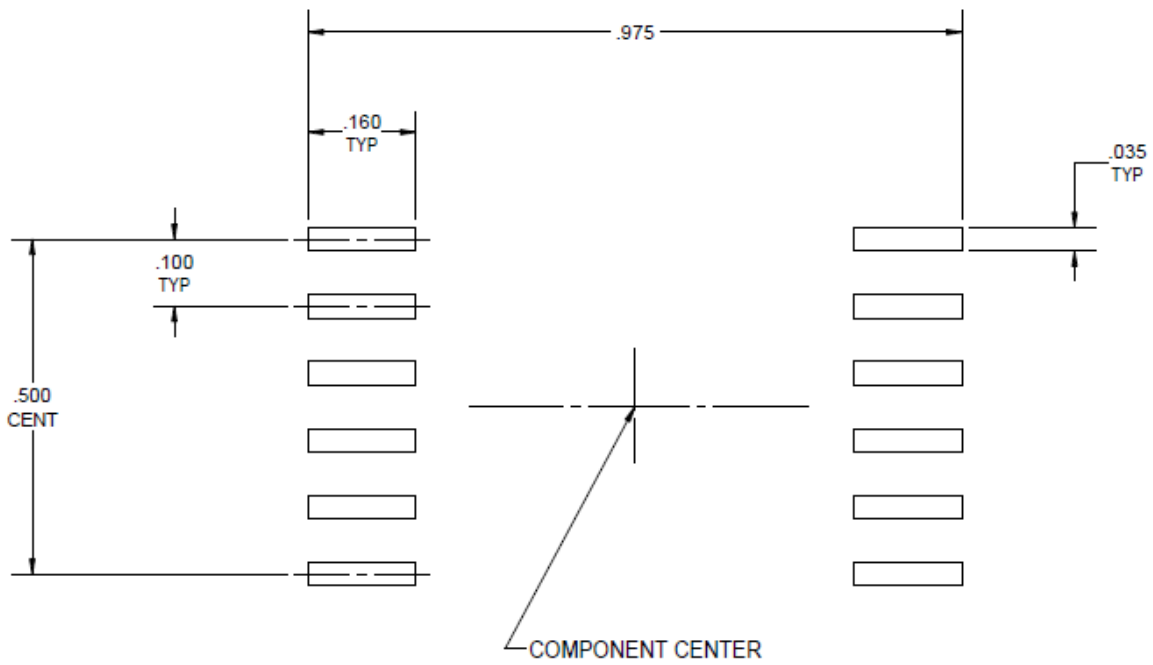

Model 1121

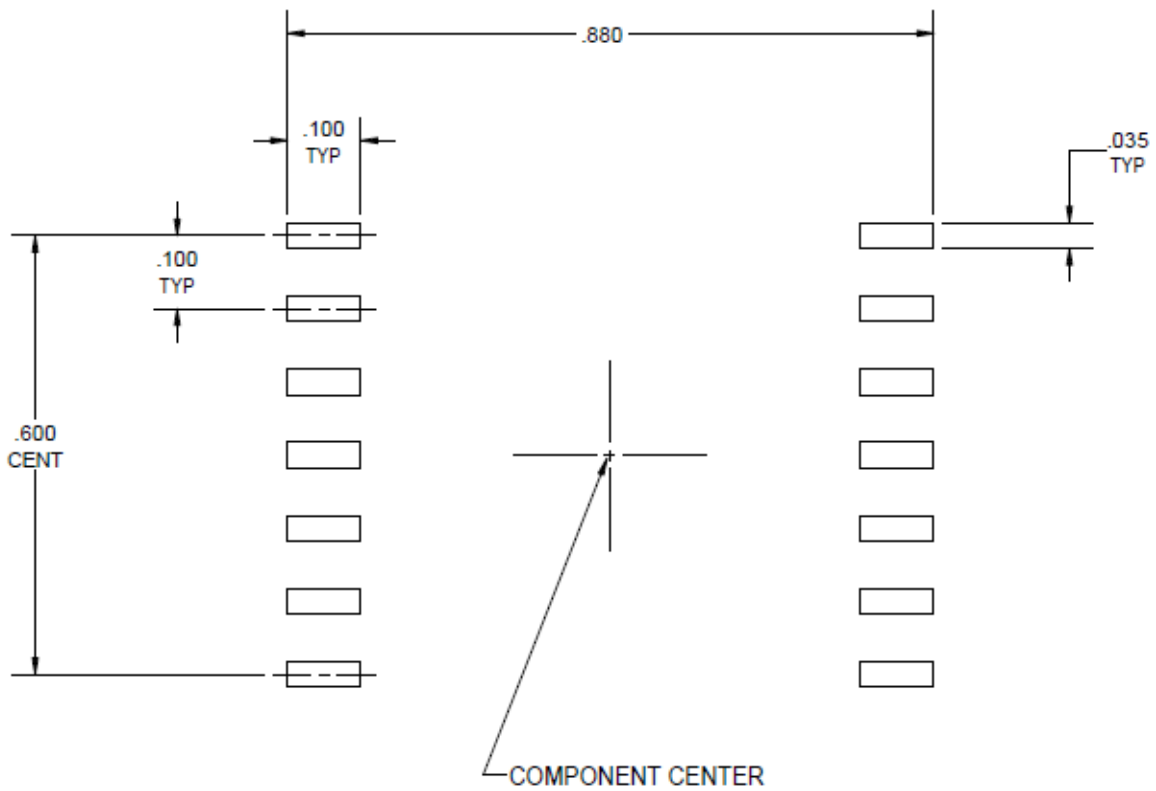

Model 1122

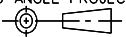
| SIZE | CODE IDENT NO. | THIRD ANGLE PROJECTION | UNSPECIFIED TOLERANCES | DWG NO. | REV. | SHEET |
|------|----------------|---|------------------------|----------|------|-------|
| A | 00136 |  | N/A | OS-68338 | M | 31 |