

Helping Customers Innovate, Improve & Grow

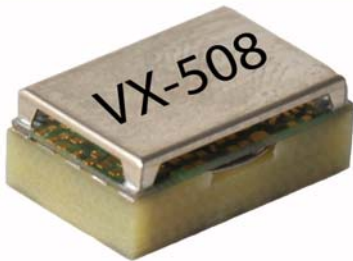

VX-508

### Features

- Low G-Sensitivity
- Vibration hardened
- Tight Tolerances
- Low Phase Noise
- Frequency Range<sup>1</sup>: 10-120 MHz

### Applications

- Vibration Environment
- Airborne and Military Equipment
- Portable Equipment
- Tactical Weapons

### Performance Specifications<sup>2</sup>

Frequency Stabilities <sup>1</sup>						
Parameter	Min	Typical	Max	Units	Condition	Options <sup>4</sup>
vs. operating temperature range (referenced to +25°C)	-15.0		+15.0	ppm	-20 to +70°C	
	-25.0		+25.0	ppm	-40 to +85°C	
	-40.0		+40.0	ppm	-40 to +105°C	
Initial tolerance	-25.0		+25.0	ppm	25°C V <sub>s</sub> ±5% static Load ±10% static after 30 days of operation after 30 days of operation	
vs. supply voltage change	-3.0		+3.0	ppm		
vs. load change	-2.0		+2.0	ppm		
vs. aging / 1 year	-1.0		+1.0	ppm		
vs. aging / 10 years	-5.0		+5.0	ppm		

## Performance Specifications<sup>2</sup>

Supply Voltage (Vs)						
Parameter	Min	Typical	Max	Units	Condition	
Supply voltage (standard)	3.135	3.3	3.465	VDC	@LVCMOS	Option <sup>4</sup>
Current consumption			30	mA		
Supply voltage	4.75	5.0	5.25	VDC	@HCMOS	
Current consumption			40	mA		
RF Output						
Signal [standard]	LVCMOS/HCMOS					
Load	13.5	15	16.5	pF		
Signal Level (Vol) LVCMOS			0.3	VDC	@ Vs=3.3V and 15pF Load	
Signal Level (Voh) LVCMOS	3.0			VDC	@ Vs=3.3V and 15pF Load	
Signal Level (Vol) HCMOS			0.5	VDC	@ Vs=5.0V and 15pF Load	
Signal Level (Voh) HCMOS	4.5				@ Vs=5.0V and 15pF Load	
Duty Cycle	40		60	%	@ (Voh-Vol)/2	
Rise and Fall time			5	ns	@15 pF 10 to 90 %	
Frequency Control (EFC)						
Tuning Range	±50.0			ppm	Frequency > 30 MHz	
	±100.0			ppm	Frequency < 30 MHz	
Linearity	<10%					
Tuning Slope	Positive					
Control Voltage Range	0.3	1.65	3.0	VDC	@ Vs=3.3V	
Control Voltage Range	0.5	2.5	4.5	VDC	@ Vs=5.0V	
EFC input impedance	10	100		kOhm		
Additional Parameters						
Phase Noise <sup>3</sup>		-78		dBc/Hz	10 Hz	@ 120 MHz LVCMOS 3.3 V
		-105		dBc/Hz	100 Hz	
		-125		dBc/Hz	1 kHz	
		-145		dBc/Hz	10 kHz	
		-160		dBc/Hz	100 kHz	
Jitter		0.064		ps RMS	@ 12 kHz to 20 MHz	
G-Sensitivity		0.5		ppb/g	@ 120MHz / 0.06g <sup>2</sup> /Hz	
Weight			8.0	g		
Processing & Packing	Handling & Processing Note					
Additional Environmental Conditions						
Random Vibration	MIL-STD-202G; Method 214A; Condition II-J, 1g <sup>2</sup> /Hz / 43.92 grms guaranteed (Qualification testing performed at MIL-STD-202G; Method 214A; Condition II-K, 1.5g <sup>2</sup> /Hz / 53.79 grms)					
Sine Vibration	MIL-STD-883; Method 2007, Test Condition B 50 g (Qualification testing performed at MIL-STD-883; Method 2007; Test Condition C 70 g)					
Shock	MIL-STD-883G; Method 2002.4; Condition D, 5000 g / 0.3 ms higher values on request					
Solderability	JEDEC J-STD-002: 100% RoHS 6 compliant					
Solvent Resistance	non-washable device					
Absolute Maximum Ratings						
supply voltage (Vs)			6.0	V		
Output Load			50	pF		
Operable Temperature Range	-40		+105	°C		
Storage Temperature Range	-40		+105	°C		

# Outline Drawing / Enclosure

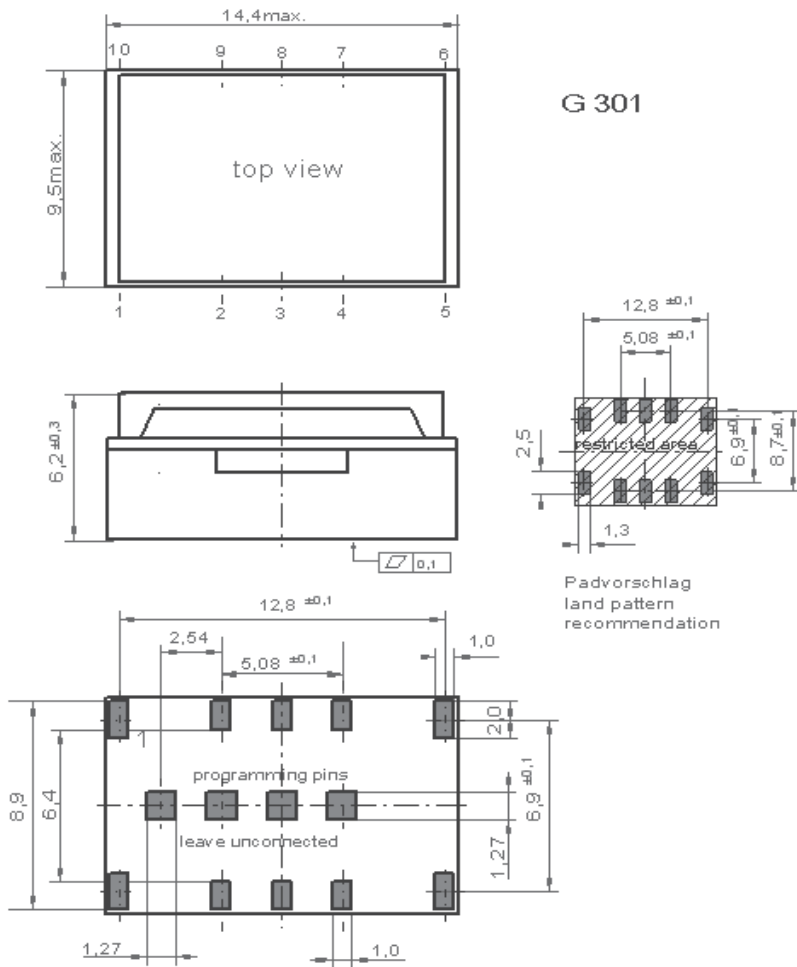

Dimensions in mm

VX-508	
Height "H"	Pin Length "L"
6.2	NA

Pin Connections	
1	N/C
2	Control Voltage Input (Vc)
3	N/C / Enable (optional)
4	Ground (Case)
5	NC
6	NC
7	RF-Output
8	NC
9	Supply Voltage (Vs)
10	NC

Enable true table (optional)	
Pin 3	Pin 7
High	Data
Open	Data
Low	High Tristate

## Typical Phase Noise @ 120 MHz HCMOS

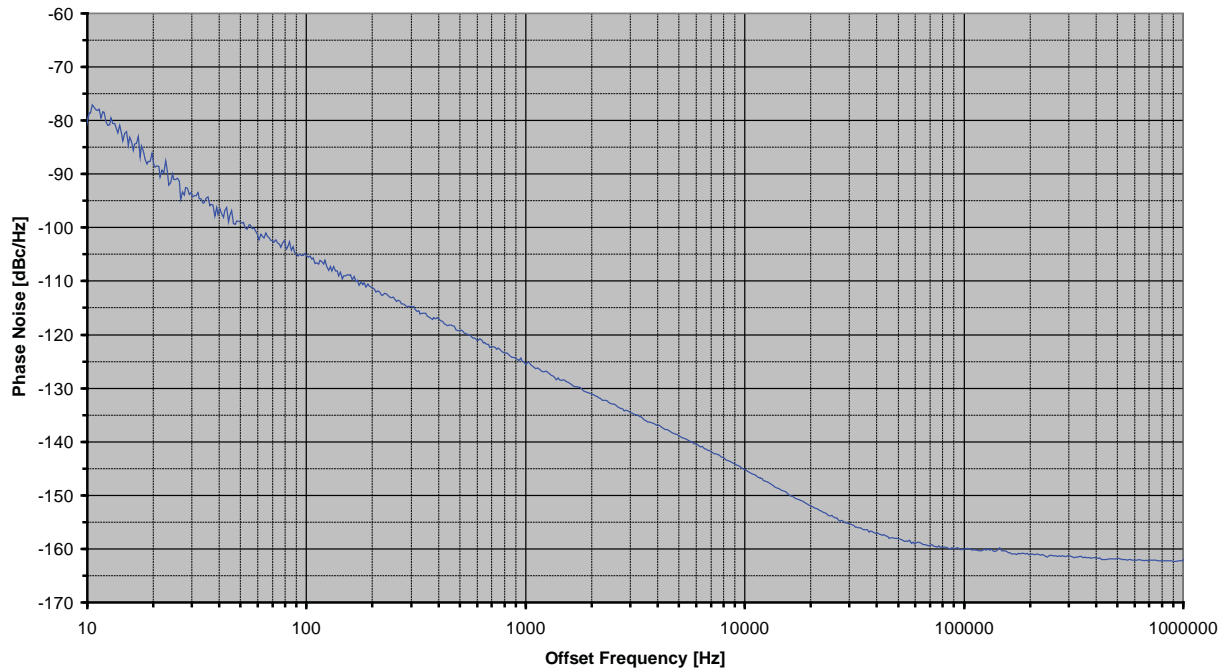

# Typical G-Sensitivity @120 MHz; HCMOS

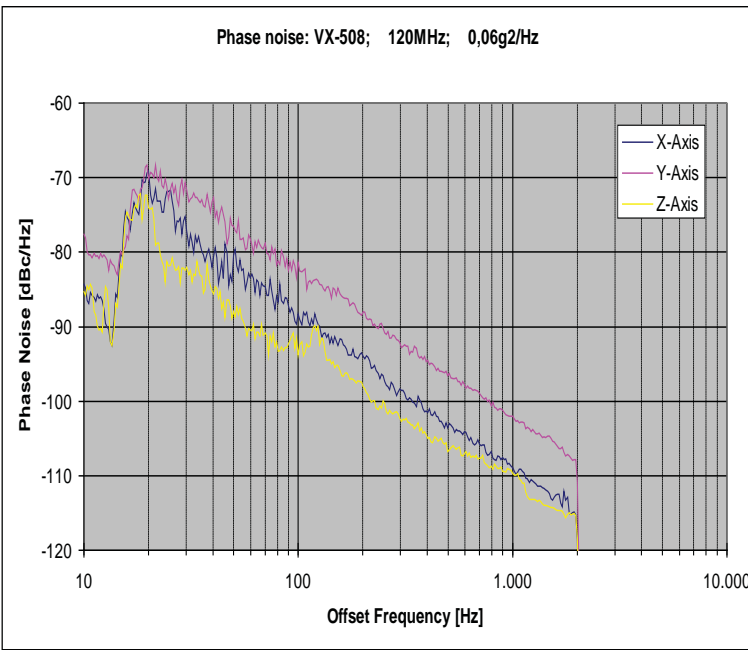
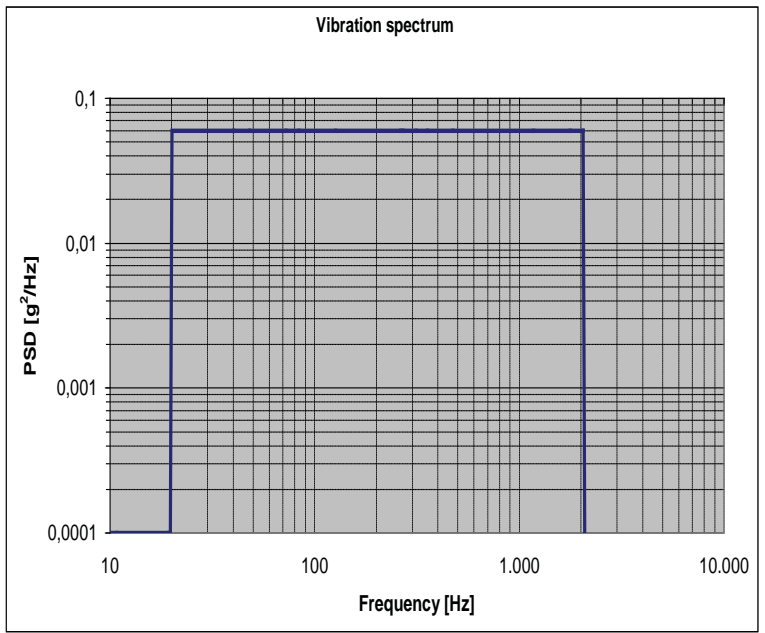
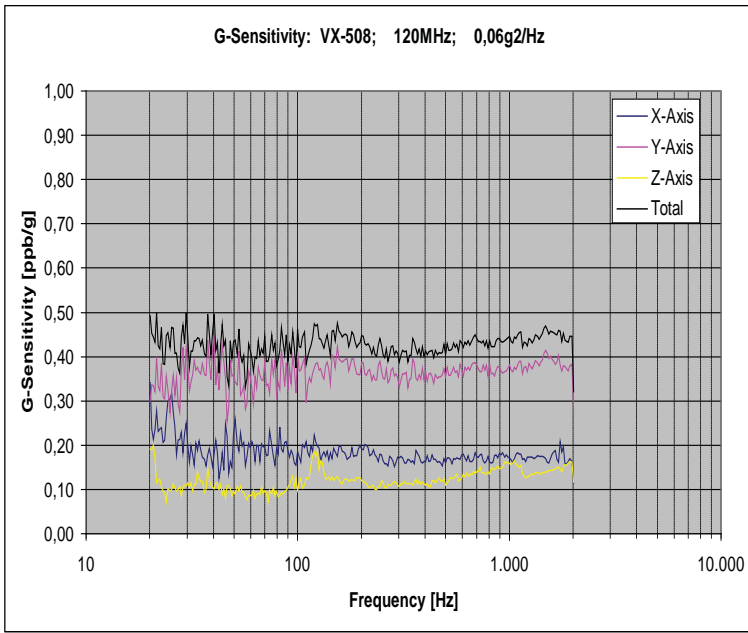

Calculation equation according to Vig-Tutorial

$$g\text{-sensitivity: } G = \frac{2 \cdot f_v}{A_{peak} \cdot f_0} \cdot 10^{\frac{L(f_v)}{20}}$$

$$\text{Peak g-level: } A_{peak} = \sqrt{PSD \cdot 2}$$

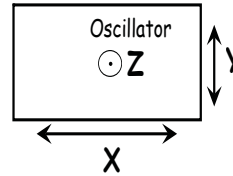

# Typical Frequency Stability vs Temperature

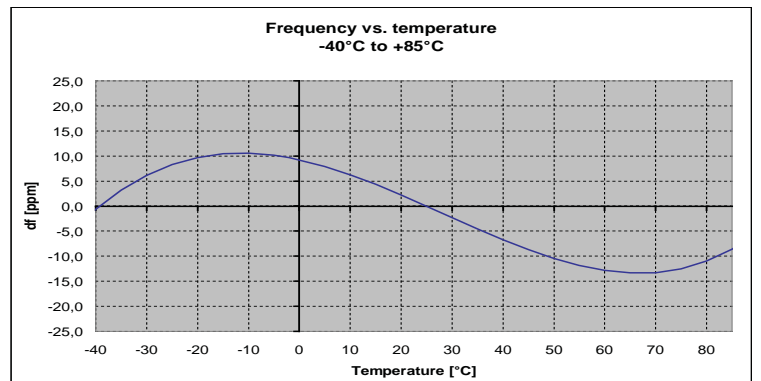
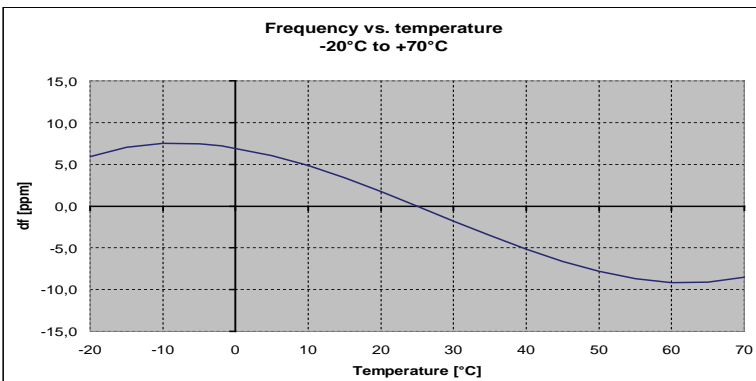

# Standard Shipping Method (VX-508)

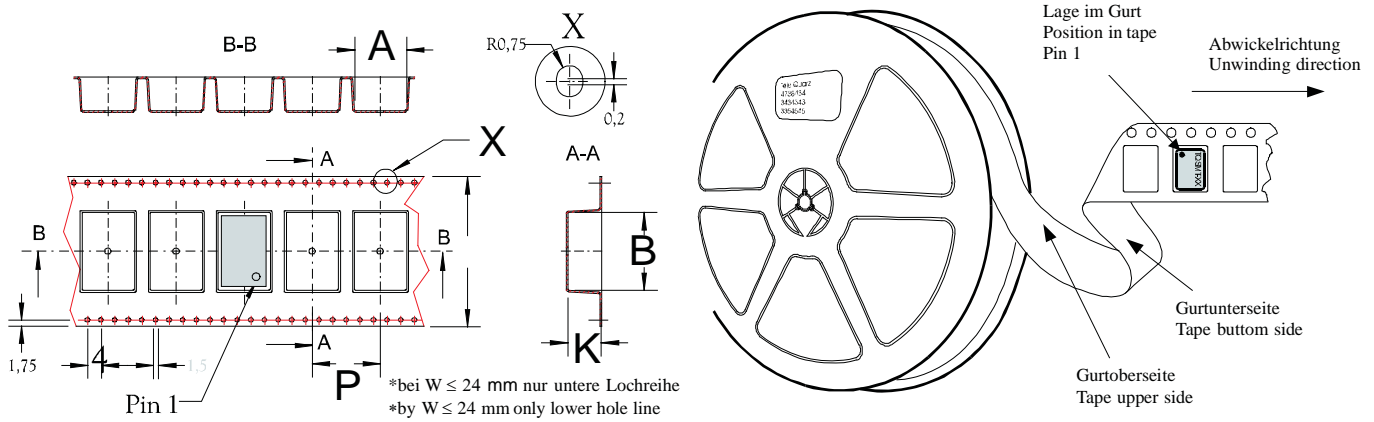

Enclosure Type	Tape Width W (mm)	Quantity per meter	Quantity per reel	Dimension P
G301	24	83,3	850	12

## Ordering Information

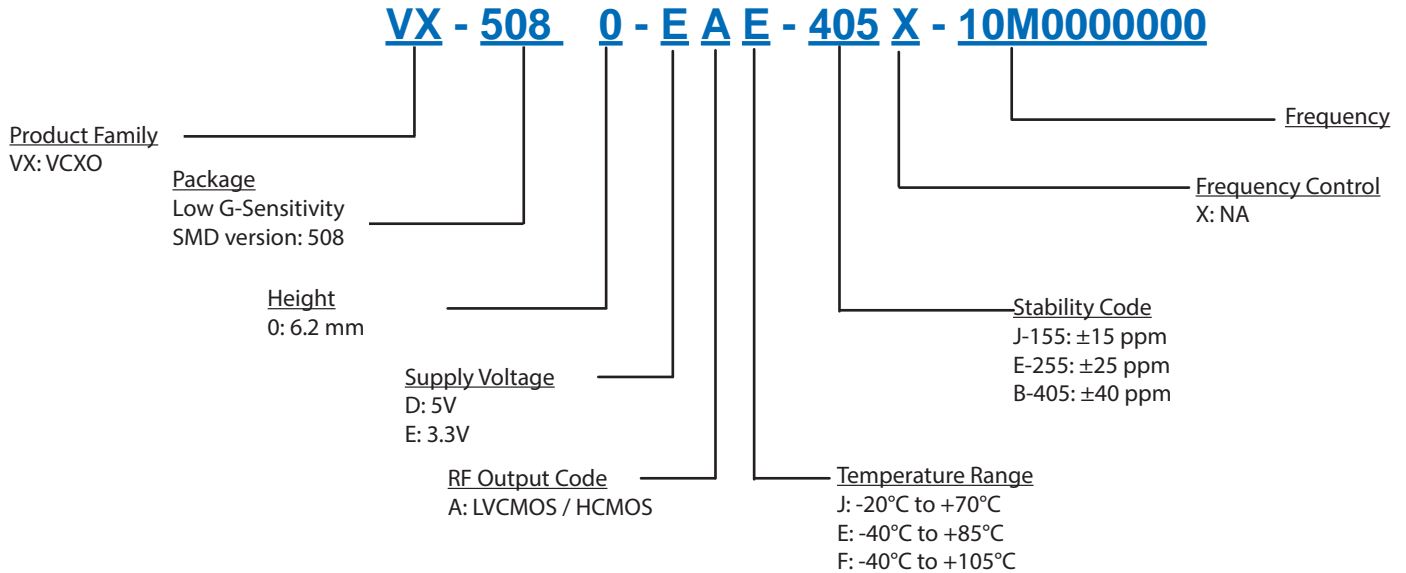

### Notes:

- Contact factory for improved stabilities or additional product options. Not all options and codes are available at all frequencies.
  - Unless other stated all values are valid after warm-up time and refer to typical conditions for supply voltage, frequency control voltage, load, temperature (25°C).
  - Phase noise degrades with increasing output frequency.
  - Contact factory for availability.
- Subject to technical modification.

## For Additional Information, Please Contact

### USA:

Vectron International  
267 Lowell Road, Suite 102  
Hudson, NH 03051  
Tel: 1.888.328.7661  
Fax: 1.888.329.8328

### Europe:

Vectron International  
Landstrasse, D-74924  
Neckarbischofsheim, Germany  
Tel: +49 (0) 7268.801.100  
Fax: +49 (0) 7268.801.282

### Asia:

Vectron International  
68 Yin Cheng Road(C), 22nd Floor  
One LuJiaZui  
Pudong, Shanghai 200120, China  
Tel: +86 21 6194 6886  
Fax: +86 21 6194 6699

### Disclaimer

Vectron International reserves the right to make changes to the product(s) and or information contained herein without notice. No liability is assumed as a result of their use or application. No rights under any patent accompany the sale of any such product(s) or information.