

Tutorial on TCXOs

Introduction to TCXOs

TCXOs are necessary when a level of temperature stability is required that cannot be reached by a standard XO (crystal oscillator) or VCXO (voltage controlled crystal oscillator).

Temperature stability is a measure of how much the oscillators frequency varies over temperature and is defined in two ways. One common approach is to use a 'plus/minus' specification (for example: $\pm 0.28 \text{ ppm}$ vs. *operating temperature range, referenced to 25°C* – with the temperature range typically -40 to 85°C or -20 to 70°C). The specification is telling us that if we take the frequency at 25°C to be nominal, then the devices frequency will deviate above or below that nominal frequency no more than 0.28ppm. This is different to the second way of specifying temperature stability, which is to use a peak to peak value or just a plus/minus value with no reference point. In the second case we can't say that we know how far above or below nominal the frequency will change – just that we know what the total range will be. Typically devices are specified using plus minus values from a defined reference point.

TCXOs are useful to an engineer because they can be used obtain anywhere from 10x to 40x better temperature stability than a standard VCXO with the same kind of power consumption and footprint on the board. TCXOs bridge the gap between a standard XO or VCXO and an OCXO, which are more expensive and require more power to run. The push for technology is towards lower power consumption and of course lower cost, so TCXOs offer a good mid range solution to power and cost sensitive applications.

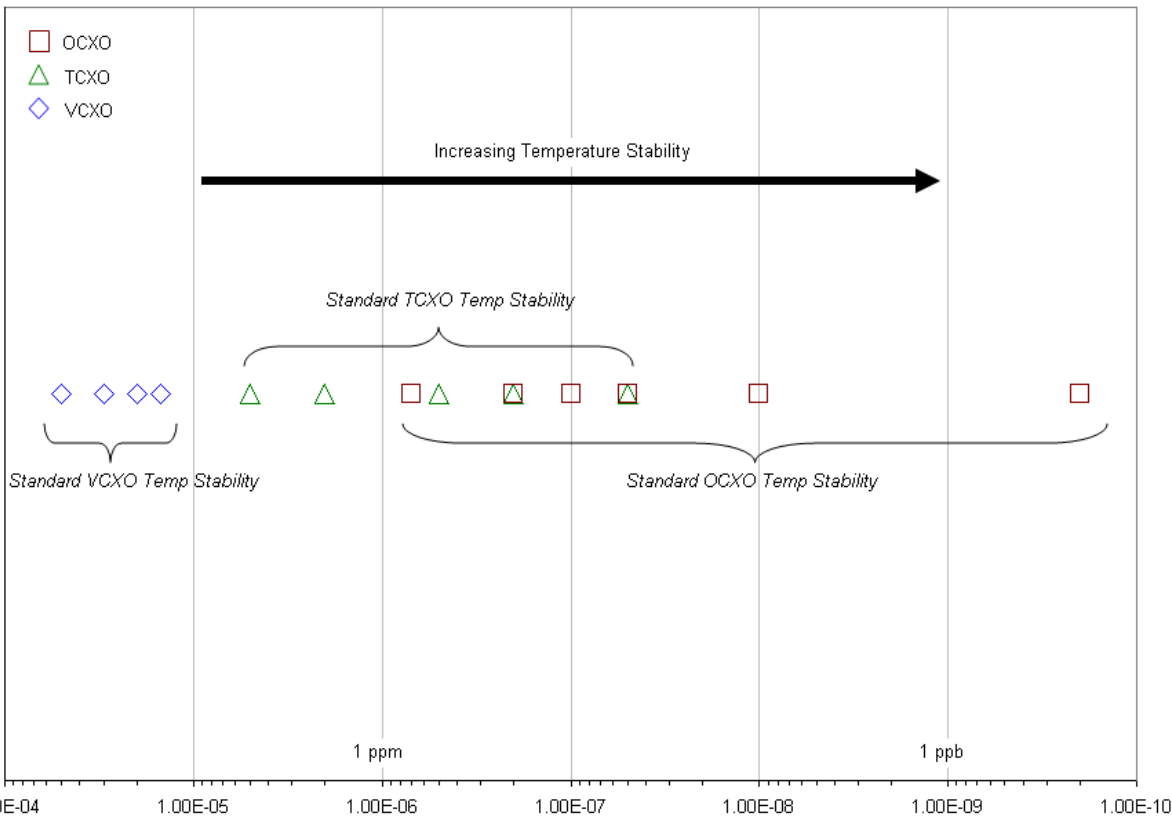

Figure 1. is an illustration of the typical temperature stabilities of different oscillator types, ranging from 50ppm for a standard VCXO to 0.2ppb for a high performance OCXO. The axis is reversed so that the plot grows in the direction of increasing temperature stability. The TCXO stability range covers the middle of the plot between the VCXOs and the OCXOs (and in some cases overlapping some OCXO performance).

Figure1. The Temperature Stability ranges of various oscillator types

A TCXO level of temperature stability (from 5ppm to 50ppb) is often necessary because the oscillator is going to be left to operate on its own, either in free run mode in a system with no external frequency reference, or as a fixed frequency reference to a synthesizer with the TCXO operating in open loop to drive a DDS (Direct Digital Synthesis) and where the DDS and not the TCXO is 'locked' to an external reference.

The latter case (TCXO is open loop and frequency is set at the DDS) is becoming more common because designers have found they can achieve better frequency resolution with a DDS solution than they can by steering the TCXO with a Digital to Analog Converter. Because the steering is being done in the DDS instead of at the oscillator, designers need to be able to make certain assumptions about how the frequency of the fixed reference will vary with temperature so that they can plan the design of the Phase Locked Loop accordingly. As a result of the flexibility they allow TCXOs get used in a host of frequency control applications, but one important area are small cell base stations (femto, micro and pico) where often they are being used as fixed frequency sources to a timing distribution chip.

How TCXOs work.

In very basic terms a TCXO operates by employing a temperature compensation network that senses the ambient temperature and pulls the crystal to its nominal value. The basic oscillator circuit and output stages are the same as one would expect in a VCXO.

Figure 2 is a simplified TCXO functional block diagram.

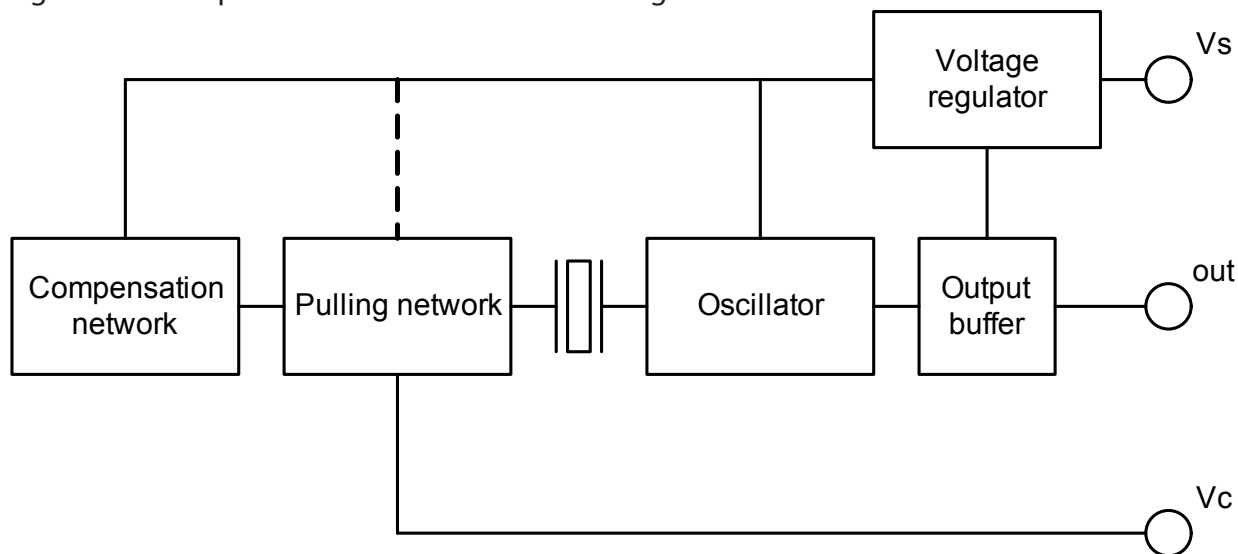

Figure 2. TCXO functional blocks

The idea is that the compensation network drives the pulling network, which then adjusts the frequency of the oscillator.

Figure 3 is an overview of what takes place – the uncompensated crystals frequency response to temperature (in red) is like a 3rd order polynomial curve (more like 5th if you take oscillator non-linearities into effect), so the aim of the compensation network is to produce a voltage that is effectively the mirror image about the temperature axis of the crystal curve in order to cancel out the effect temperature has on the crystal. The compensating voltage is shown in blue, and the resulting frequency/temperature curve is plotted in green.

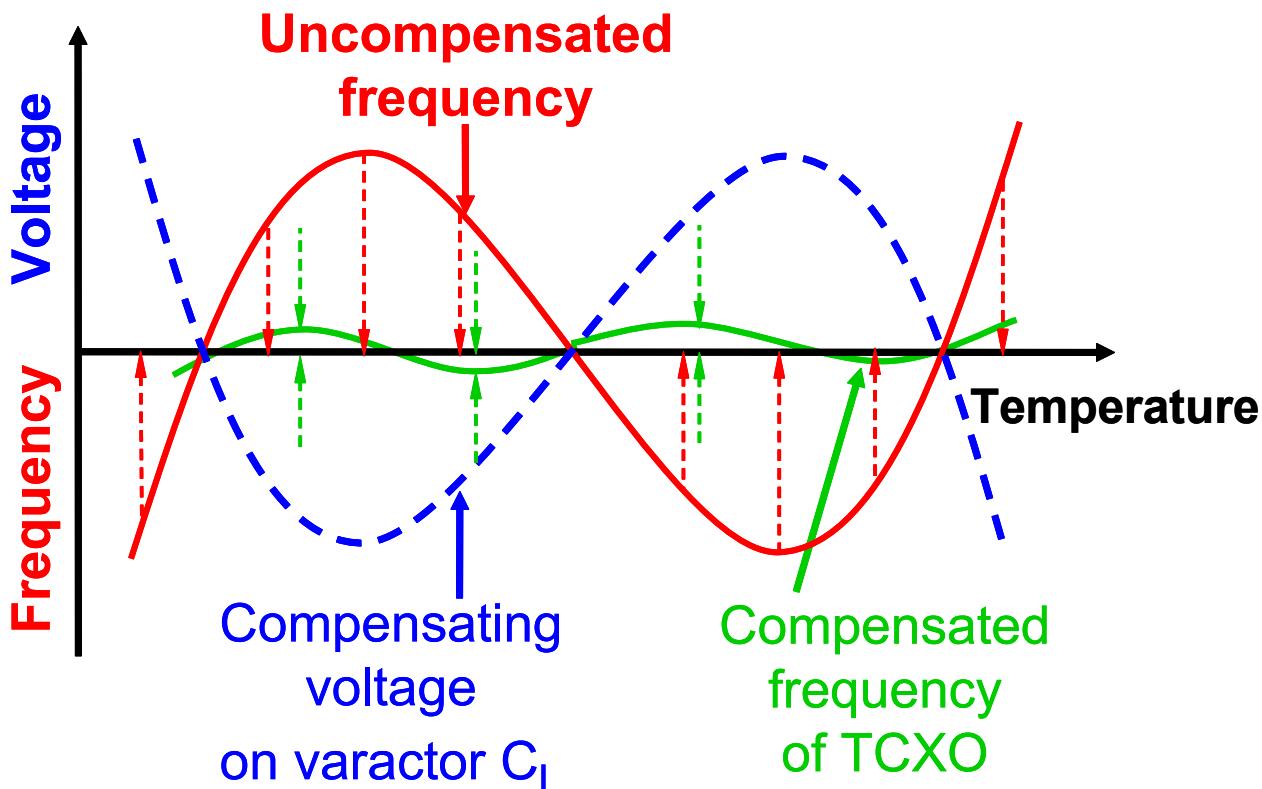

Figure 3. Temperature compensation

The approach to achieving this has changed over time. One of the first approaches used was a direct compensation technique in which a network of thermistors, capacitors and resistors was used to directly control the frequency of the oscillator. A change in the temperature causes the thermistors (RT1 and RT2 in Figure 4) to vary, which causes a change in the equivalent series capacitance of the network – this in turn changes the capacitance load on the crystal, causing a change in the frequency of the oscillator.

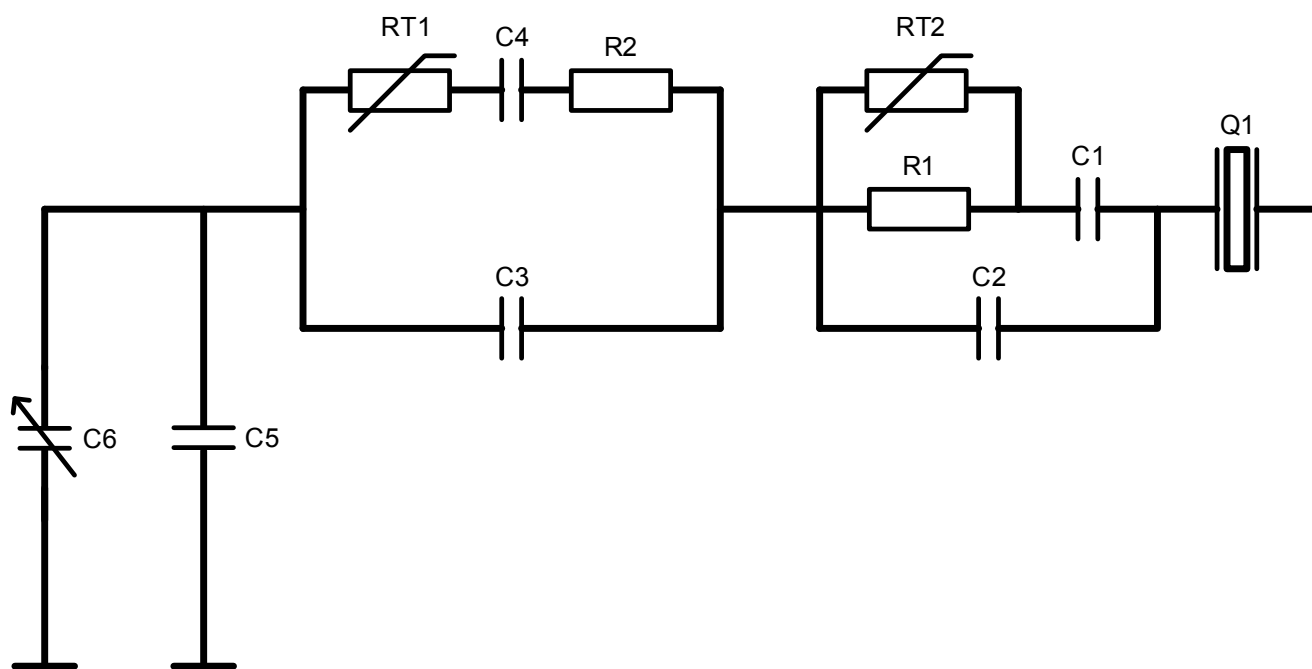

Figure 4. Direct Compensation

In a subsequent development (indirect compensation shown in Figure 5) a network of thermistors (RT1 to RT3) and resistors (R1 to R3) is used to produce a temperature dependant voltage. The output voltage of the network is filtered and then used to drive a varactor which varies the load across the crystal, again resulting in a frequency change.

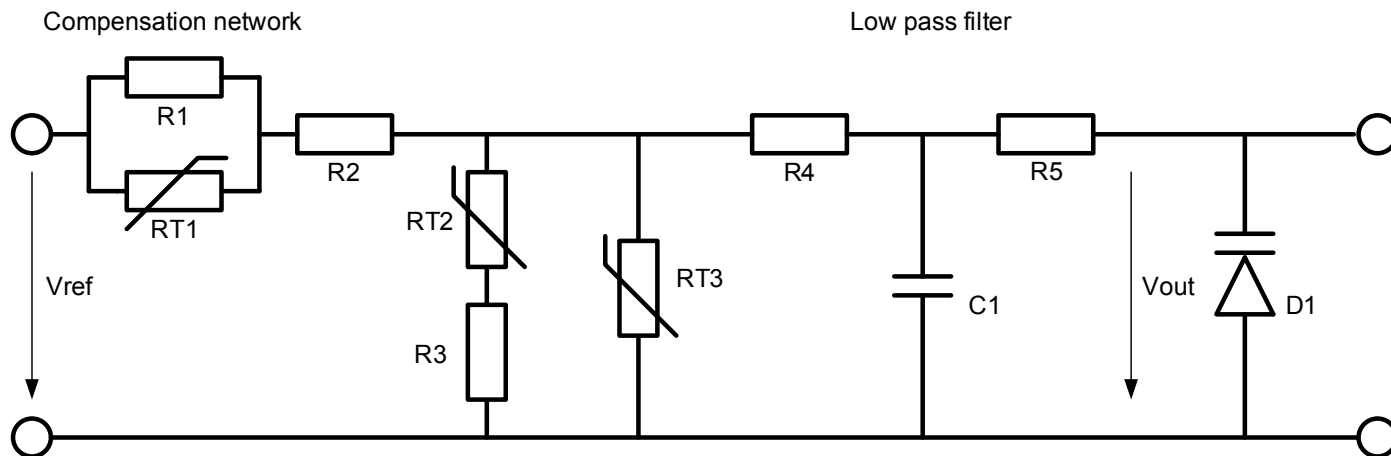

Figure 5 Indirect Compensation

The current approach integrates the compensation network and pulling network into an integrated circuit (outlined in Figure 6), and the role of the compensation network is played by a set of op-amps that summed together produce a 3rd or 5th order function over temperature. As with the indirect compensation approach this voltage is used to drive a varactor, which in turn varies the output frequency of the oscillator. Since variations in crystal characteristics mean that there is not a 'one size fits all' function the solution is derived during temperature testing of the TCXO. Two capacitor arrays are used to adjust the frequency at room temperature to nominal, and then the settings required for the temperature compensation function are obtained during testing and stored in on chip memory.

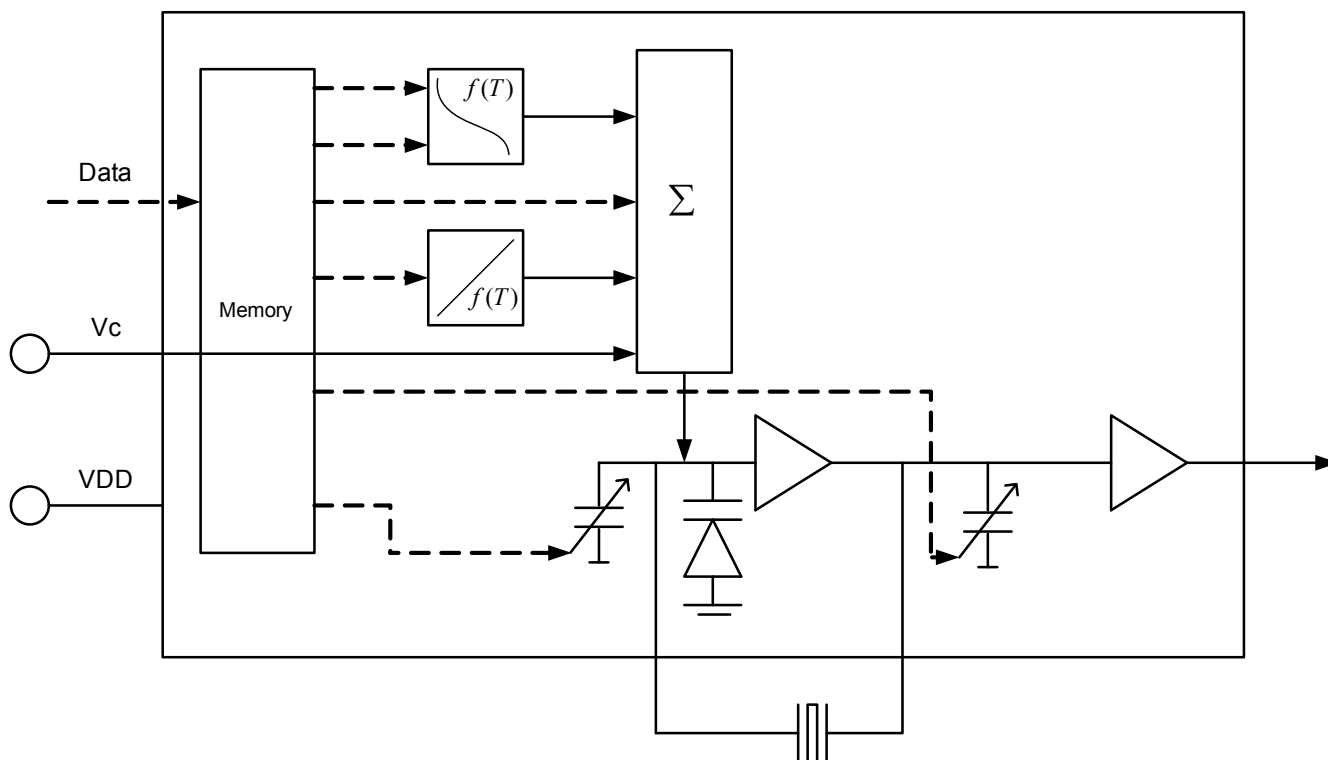

Figure 6 Integrated Compensation

This last approach is often referred to as 'digitally controlled analog compensation', and is commonly found in small form factor TCXO designs because of the amount of functionality that can be made available in a single ASIC.

Hopefully this short introduction has given you an overview of TCXOs and the various ways they can be implemented. For more information on TCXO or other oscillator technology please take a look at our other application notes on-line at:

http://www.vectron.com/products/literature_library/index.htm

Review our TCXO offerings at:

http://www.vectron.com/products/tcxo/tcxo_index.htm

or contact Vectron at:

<http://www.vectron.com/contact/index.htm>

For Additional Information, Please Contact

USA:

Vectron International
267 Lowell Road, Unit 102
Hudson, NH 03051
Tel: 1.888.328.7661
Fax: 1.888.329.8328

Europe:

Vectron International
Landstrasse, D-74924
Neckarbischofsheim, Germany
Tel: +49 (0) 7268.8010
Fax: +49 (0) 7268.801281

Asia:

Vectron International
68 Yin Cheng Road(C), 22nd Floor
One LuJiaZui
Pudong, Shanghai 200120, China
Tel: 86.21.61946886
Fax: 86.21.61633598

Disclaimer

Vectron International reserves the right to make changes to the product(s) and or information contained herein without notice. No liability is assumed as a result of their use or application. No rights under any patent accompany the sale of any such product(s) or information.