

Lo-Carbon Sentinel Multivent/Plus

Features & Benefits

- Reduces your carbon footprint
- Recognised in SAP PCDB
- Specific fan power 0.16 W/l/s (K+1)
- Suitable for use with external sensors and controllers
- Wireless control option
- Complies with Building Regulations ADF and ADL
- Manufactured in the UK from recyclable materials



Sentinel Multivent continuous mechanical extract ventilation, MEV is designed for the simultaneous ventilation of separate areas in the home or as a multipoint extraction system for a wide range of commercial applications. The units can be installed at any angle. Where the ambient air has a high humidity content condensate drains are provided.

In support of Sentinel Multivent, Vent-Axia offers:

- Practical advice on product selection and installation
- Guidance on solutions to meet legislation requirements
- Project management and site deliveries
- After sales support and maintenance information

The need to improve efficiency

Sentinel Multivent has been designed to meet the exacting demands of developers, installers and users offering advanced control options and easier installation and commissioning.

- Demand Control - enables precise ventilation rate, is set in 1% increments based on property size
- Integral LCD display allows the installer to select appropriate low, normal and boost speeds to meet demand
- Manual and automatic control options
- Integral adjustable overrun timer and delay on timer
- Plug-n-Play automatic sensor detection
- Switched live and SELV connections
- Dry Out setting - Option set at installation, Sentinel Multivent will run on boost for 1 week to assist in removing moisture
- Optional Wireless Control - up to 4 controllers on any one system
- Energy efficient EC/DC motors - 1/3 less energy lost to heat than a conventional AC motor
- Low Specific Fan Power (SFP) making it one of the most efficient products on the market

Legislation

- Meets Building Regulations Approved Document F (System 3)
- Recognised in SAP PCDB up to kitchen + 6 wet rooms

- Meets carbon footprint reduction targets
- Lowest SFP figures of any demand control MEV system

The need for better health

Removal of pollutants such as moisture, carbon dioxide and external fumes are all important factors in maintaining indoor air quality, helping to create a healthier living environment.

- The integral humidity sensor (Sentinel Multivent H) increases fan speed in proportion to relative humidity levels, saving energy and reducing noise
- The sensor also reacts to small but rapid increases in humidity, even if the normal trigger threshold is not reached. This unique feature ensures adequate ventilation, even for the smallest wet room
- Night time relative humidity increment setback feature suppresses nuisance tripping as humidity gradually increases with falling temperature
- Acoustically lined - low noise levels only 18.1 dB(A) @ 3m

SAP PCDB

In order to make the right choice, developers and contractors should refer to Building Regulations ADL1a, SAP 2012 and SAP PCDB.

SAP PCDB was launched in June 2006 to reward innovative ventilation manufacturers by testing and listing energy efficient products that assist in helping developers meet their Target Emission Rates (TER).

SAP is the underpinning methodology behind the Energy Performance Certificates and is used to demonstrate compliance with Building Regulations for Dwellings - Approved Document L (England and Wales), Section 6 (Scotland) and Approved Document F (Northern Ireland). SAP PCDB specifically relates to wholehouse ventilation systems and lists a number of Vent-Axia Mechanical Ventilation solutions which offer an improved SAP rating over and above the default for these product types.

SAP PCDB Test Results (Sentinel Multivent Plus)

Exhaust Terminal Configuration	Fan Speed Setting	Total Flow Rate	SFP (W/l/s)
K+1	20%	21	0.25
K+2	25%	29	0.22
K+3	30%	37	0.22
K+4	34%	45	0.22
K+5	40%	53	0.25
K+6	45%	61	0.27

SAP PCDB Test Results (Sentinel Multivent)

Exhaust Terminal Configuration	Fan Speed Setting	Total Flow Rate	SFP (W/l/s)
K+1	32%	21	0.16
K+2	39%	29	0.16
K+3	49%	37	0.17
K+4	59%	45	0.21
K+5	68%	53	0.24
K+6	77%	61	0.29

To assist developers and contractors Vent-Axia can provide detailed scheme designs together with installation guidance and training.

Your Carbon Footprint

The Carbon Footprint is a measure of the amount of carbon dioxide (CO₂) emitted through the burning of fossil fuels. From a residential and commercial building perspective, it is the amount of carbon generated when you consume a kilowatt of electricity. Reducing a building's carbon footprint will ultimately reduce electricity bills and save money for every individual household or business. It will also help meet the UK target for the reduction of emissions, as well as allowing you to help the environment.

Model

Model	Stock Ref
Sentinel Multivent	437601
Sentinel Multivent H	445655
Sentinel Multivent Plus	407001
Sentinel Multivent Plus H	407849

Dimensions (mm)

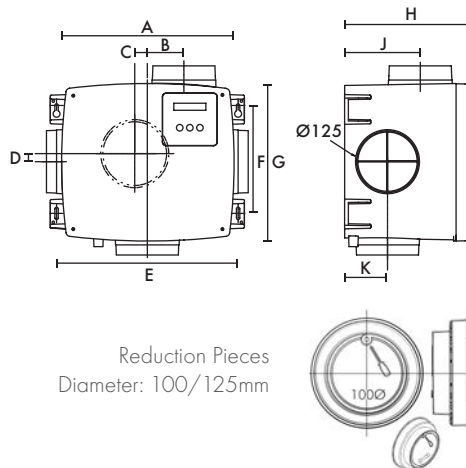

A	B	C	D	E	F	G	H	I	J
340	72.5	25	15	360	214	310	260	150	85

Performance Guide

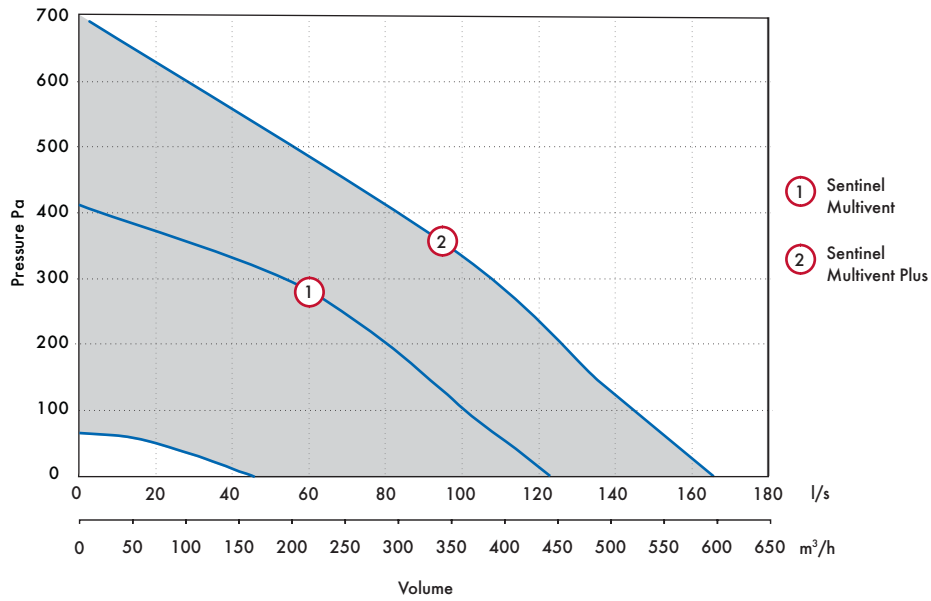

Stock Ref	Model	Curve Ref	Inlet Duct dB(A)	FID l/s	Power Watts	SEC Class	SEC Class (inc. LDC)
437601 / 445655	Multivent	1 (max)	38	121	45	E	B
407001 / 407849	Multivent Plus	2 (max)	-	165	83	E	B

Sound Data (Sentinel Multivent Plus)

Speed %	Test mode	Octave band, Hz, dB SWL								SPL dB(A) at 3m
		63	125	250	500	1k	2k	4k	8k	
20	Inlet	45.0	46.0	43.9	34.1	27.4	22.8	23.1	29.7	20.5
	Outlet	45.0	40.9	45.2	39.5	33.0	26.7	23.0	29.1	29.5
	Breakout	43.9	37.4	36.5	35.5	26.7	22.6	23.7	30.2	19.0
40	Inlet	48.6	48.7	54.4	52.3	55.4	47.5	38.0	33.1	37.0
	Outlet	49.1	54.6	54.4	55.0	55.7	51.7	39.7	39.5	42.9
	Breakout	45.2	44.2	47.5	46.1	40.0	34.0	26.3	30.3	26.8
60	Inlet	48.6	48.7	54.4	52.3	55.4	47.5	38.0	33.1	37.0
	Outlet	57.1	55.9	65.2	63.3	64.8	64.5	53.7	55.5	52.2
	Breakout	49.0	49.7	58.0	53.7	48.4	46.4	36.4	33.3	34.9
80	Inlet	56.3	56.6	60.4	59.0	61.4	56.0	46.6	43.5	43.5
	Outlet	62.3	60.8	70.9	69.3	69.5	70.3	61.9	62.8	57.9
	Breakout	53.1	53.7	61.8	61.4	53.4	54.5	44.9	41.9	41.3
100	Inlet	54.1	55.5	59.4	61.8	62.7	58.9	49.7	45.8	45.3
	Outlet	63.1	61.8	67.8	72.7	70.5	71.5	62.9	64.4	59.0
	Breakout	56.5	54.3	60.8	65.6	54.0	54.6	46.3	42.3	43.7

Sound Data (Sentinel Multivent)

Speed		Induct sound power levels dB								dB(A) @ 3m
		63	125	250	500	1K	2K	4K	8K	
10%	Breakout	43.6	37	36.9	30.6	26.2	22.8	23.6	30.4	18.1
	Extract	43.8	39.9	36.1	30.4	24.6	21.8	22.	30.3	17.8
28%	Breakout	44	44.4	43.3	39	31.1	26.1	24.3	30.1	22
	Extract	42.2	40.1	42.2	40.5	32	23.3	23.4	30.5	22
46%	Breakout	45	42.8	46.7	44.1	38.8	35.6	26.7	30.6	25.8
	Extract	40.8	42.5	46.4	44.4	41	31.1	25.3	30.3	26
82%	Breakout	46.3	48.3	50	52.1	48.4	47.7	37.8	32.4	33.7
	Extract	46.7	49.6	48.9	54.3	51.8	42.7	38.1	34.2	36.1

Controllers and Sensors

Sentinel Multivent can be used with a wide range of Vent-Axia controllers and sensors. Ranging from integral humidistats, through to wireless controllers to wired remote sensors.

Integral Humidistat

- Simple Plug-n-Play installation
- Eliminates the need for additional controllers or sensors
- Reacts to any rapid increases in relative humidity or when humidity rises above adjustable threshold
- Future proof - can be fitted after installation
- Self programming

Stock Ref

437598



Wireless Transmitter Controller

- Additional controller for 439352
- A maximum of 4 controllers can be used per system
- Can be connected to other accessories (e.g. Humidistat) to send a boost signal wirelessly

Stock Ref

437827



Ambient Response Humidity Sensor

- Pullcord override and indication light
- Changeover relay switch
- Operating range: 30% - 90%RH
- Ambient operating temp. 5°C to 40°C
- 220-240V AC
- Will fit single gang box for surface mounting

Stock Ref

563550



Air Quality Sensor

- Ambient operating temp. 0°C to 50°C
- DEMKO approved
- Surface mounted
- 1 - 25 min O/R timer
- Supply voltage 220-240V

Stock Ref

563506



Visonex PIR Sensor

- Fits any UK single gang mounting box
- Adjustable timer overrun (5-25 mins)
- Range of detection up to 10 metres
- Designed to meet IP43
- Ambient operating temp. range 0°C to 50°C

Stock Ref

459623



Ventwise

- Automatically boosts fan when temperature of the supply pipe to a shower or bath increases
- Automatically boosts fan when electric hob is switched on
- Can be used in conjunction with manual override input
- Adjustable overrun timer
- Two sensor options available

Stock Ref

435960



Wireless Transmitter Controller Receiver Kit

- Manual boost
- Adjustable overrun timer
- Easy wireless installation
- Reduces installation time
- Future proof - add more controllers any time

Stock Ref

439352



Ecotronic Humidity Sensor

- Set point adjustable
- Maximum switching load 1 Amp inductive
- Pullcord override indicator
- Ambient operating temp. 0°C to 40°C
- Supply voltage 220-240V

Stock Ref

563532



CO₂ + Temp Room Sensor

- 240V DC
- 0 - 2000ppm CO₂ working range
- 0 - 50°C working range
- Auto-calibrating NDIR CO₂ absorption sensor
- Thin film platinum temperature sensor for high accuracy

Stock Ref

433257

