

Web-Based Remote Monitoring & Datalogging

WebAlert®

WebAlert was developed to meet the increasing demands for improved operational efficiencies and enhancements to service programs that can be gained by continuous monitoring of remote equipment and systems.

WebAlert seamlessly web-enables your installed equipment, providing local and remote access to vital system information, without the need to physically visit remote sites. WebAlert monitors and datalogs analog and digital inputs from virtually any installed device, and notifies on-site and remote personnel of any system abnormalities.

The data handling and communications options in WebAlert are truly innovative. Ethernet and USB are standard features, therefore local or plant networked PC's can be connected and communicating with WebAlert in true Plug & Play fashion. Authorized operators and quality control personnel can view LIVE system parameters and historical graphs, as well as receive emailed alarms, reports or datalog files.



Summary of Key Benefits

- WebAlert integrates the functions of a monitor, data logger and auto-dialer in one low cost package. It is easily customized to your application without the need for a programmer.
- VTouch® provides quick, centralized 24/7 awareness of account status with the ability to LIVE Connect to any of your controllers in the field with one simple mouse-click.
- No subscription service, monthly fees, or proprietary software is required. View data and program settings with just a standard web browser.
- Monitor up to six (6) 4-20mA signals and six (6) discrete inputs.
- Access live or stored data remotely within the facility (LAN) or from anywhere in the world.
- System status reports and datalog files can be emailed automatically on a regular basis. Instant alarm notification via cell phone text message, email, or local alarm relay.



W A L C H E M

IWAKI America Inc.

Features

WebAlert® Series | Web-Based Remote Monitoring and Datalogging

Convenience

WebAlert has been designed with convenience and ease-of-use in mind. It has extensive built-in datalogging capability so there's no need for a separate datalogging device. The data can be retrieved automatically (email Excel file attachment) or manually, through the convenience of a standard USB flash disk.



Simple data extraction to USB stick

Simplicity

Unlike PLC's or similar devices, WebAlert does not require a software programmer for customization to your application. This reduces upfront costs and eliminates recurring expenses for software maintenance. Commissioning is as simple as connecting with a laptop and following the intuitive menus to configure the WebAlert to meet your needs.



Receive spreadsheet datalogs as an attachment to an email at user-defined time periods.

A variety of reporting options can be utilized to meet your needs. A system summary report provides a snapshot of current conditions and alarms. A datalog report can be sent on a regular basis for historical trending. In addition, email and cell phone text alarm messages can be sent.



Receive alarms via cell phone text messaging.

Remote Chemical Inventory Management

WebAlert is perfect for remote chemical inventory management. Level sensors and switches from a variety of sensing devices may be connected directly to the WebAlert, providing live information about chemical inventories, which makes management of chemical deliveries efficient, prevents down-time in critical processes, and provides immediate notification of alarm conditions. An online device management service from Walchem will be available to enable the user to view all of their locations on a single web page.

Online Device Management Service

- Critical Process Values
- Summary View of Devices
- One Click Live Connect
- Alarm Status
- Monthly Reports

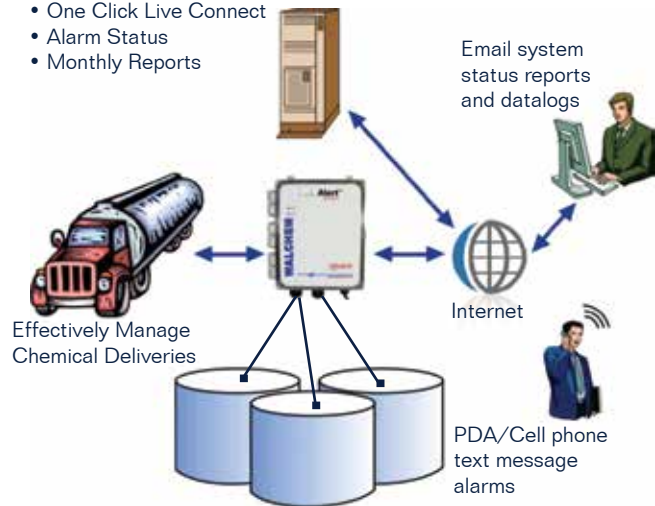

Remote System Monitoring

WebAlert will monitor up to six (6) 4-20mA signals and six (6) discrete inputs, giving you instant access (from anywhere in the world) to vital system parameters, including level, flow, pressure, temperature, or any other device with a standard 4-20mA or discrete output.

WALCHEM WebAlert Alarm Status: ● 1) ORP(AI_2)LowAlarm Controller Restart

Thu May 24 08:19:27 2007

| 4-20mA Inputs | Measure | Last 24 Hrs | | | Status | Total |
|-------------------|---------------|-------------|--------|--------|------------|----------------|
| | | AVG | MIN | MAX | | |
| pH(AI_1) | 7.65 pH | 7.65 | 7.65 | 7.65 | Normal | N/A |
| ORP(AI_2) | -43.37 ORP | -43.35 | -43.37 | -40.55 | Low Alarm | N/A |
| FlowMeter2(AI_4) | 84.78 Gal/min | 84.72 | 84.85 | 84.79 | Normal | 1323313.00 Gal |
| Bleach Tank(AI_5) | 434.95 gal. | 434.63 | 433.54 | 434.05 | High Alarm | N/A |
| Acid Tank(AI_6) | 40.55 gal. | 40.55 | 40.55 | 40.55 | Normal | N/A |

| Digital Inputs | Input Type | Status | Total | Rate |
|-------------------|------------------------|-------------------------|----------|------|
| Flowmeter2(DI_1) | Contact Flow Meter | Normal | 2251.39 | gal |
| Flow Switch(DI_2) | Generic Input | Flow 1 days, 15:40:00 | N/A | N/A |
| Switch1(DI_3) | Generic Input | Open 1 days, 15:40:00 | N/A | N/A |
| FlowMeter1(DI_4) | Paddlewheel Flow Meter | Low Alarm | 93903.92 | gal |
| Switch2(DI_5) | Generic Input | Open 1 days, 15:40:00 | N/A | N/A |
| Switch3(DI_6) | Generic Input | Open 00:15:23 | N/A | N/A |

Specifications

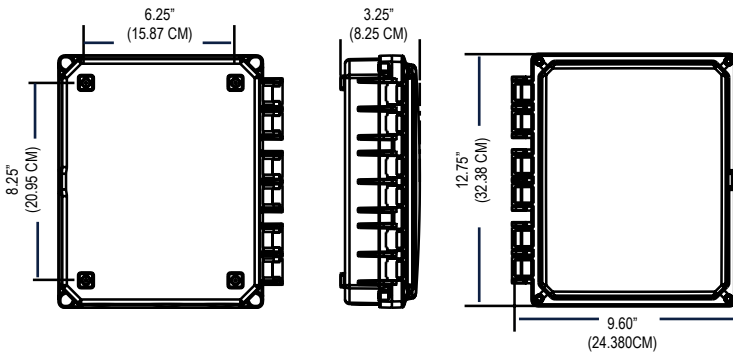

Mechanical Specifications

| | |
|----------------------|-------------------------------|
| Enclosure: | Polycarbonate |
| NEMA Rating: | NEMA 4X (IP65) |
| Ambient Temperature: | 32 to 140°F (0 to 60°C) |
| Storage Temperature: | -20 to 176°F (-29 to 80°C) |
| Shipping Weight: | 18 lbs (8.2 kg) (approximate) |

Measurement Performance

| | |
|--------------|---------------|
| Range: | 3.75-20.25 mA |
| Resolution: | 0.03 mA |
| Calibration: | ±1 mA |

Electrical

| | |
|--------------|--------------------|
| Input Power: | 100-240VAC ± 10% |
| | 1.0A, 50/60 Hz |
| | Fuse 1.0A 5 x 20mm |

Input Signals:

State-Type Digital Inputs

Electrical: Non-Isolated 5 VDC with 301 K ohm pull-up
 Typical response time: < 10 seconds
 Devices supported: Any isolated dry contact (i.e. relay, reed switch)
 Support on inputs: 1 through 6
 Types: Generic input

Low Speed Counter-Type Digital Inputs

Electrical: Non-Isolated 5 VDC with 301 K ohm pull-up, 0-10 Hz,
 50 msec minimum width
 Devices supported: Any device with isolated open drain, open collector,
 transistor or reed switch
 Support on inputs: 1 through 4
 Types: Contacting flow meter, Generic counter

High Speed Counter-Type Digital Inputs

Electrical: Non-Isolated 5 VDC with 301 K ohm pull-up, 0-400 Hz,
 1.25 msec minimum width
 Devices supported: Any device with isolated open drain, open collector,
 transistor or reed switch
 Support on inputs: 1 through 4
 Types: Paddlewheel flow meter, Generic counter

Analog Inputs (1-6)

4-20 mA, 2-wire or 3-wire, internally powered by 24 VDC, 110 ohm input
 resistance, 1000 ohm maximum load, Typical response time < 10 seconds

Outputs:

Solid State relay Digital

Dry contact, 0 to 40 VDC, No AC voltage, 150 mA maximum load
 USB, Ethernet, 10 Base T

Agency Certifications

| | |
|--------|--|
| Safety | UL 61010-1:2012 3rd Ed. CSA C22.2 No. 61010-1:2012 3rd Ed. IEC 61010-1:2010 3rd Ed. EN 61010-1:2010 3rd Ed. |
| EMC | IEC 61326-1:2012 EN 61326-1:2013 |

Note: For EN61000-4-6, and EN61000-4-3 the controller met performance criteria B.

*Class A equipment: Equipment suitable for use in establishments other than domestic, and those directly connected to a low voltage (100-240 VAC) power supply network which supplies buildings used for domestic purposes.

Communications

WebAlert's embedded web-server and TCP/IP Internet communications make it possible to establish local or remote communications with a standard web browser from a laptop or PC. USB and Ethernet are standard features, allowing easy on-site access for plant personnel and system operators. Remote communications can be accomplished via the Internet or over a phone line with the PSTN (landline) or Cellular modem option. WebAlert supports simultaneous multi-user access, which makes it possible for personnel from local and remote locations to view live data, troubleshoot, and configure the system more efficiently than ever before. A graduated password protection system allows users varied degrees of access from "view only" to "full configuration".

- **USB Plug and Play:** For local monitoring and reconfiguration of your WebAlert via LapTop or dedicated on-site PC.
- **ShoulderTap® Internet Communications:** For monitoring and reconfiguration of your WebAlert remotely via the Internet (requires landline modem card option).
- **DirectTap Modem-to-Modem:** For remote monitoring and reconfiguration of your WebAlert using traditional modem-to-modem communications (requires landline modem card option).
- **Ethernet:** For monitoring and reconfiguration of your WebAlert via Local Area Network or remotely via the Internet
- **Cellular:** For monitoring and reconfiguration of your WebAlert remotely via the Internet (requires cell modem and VTouch option).

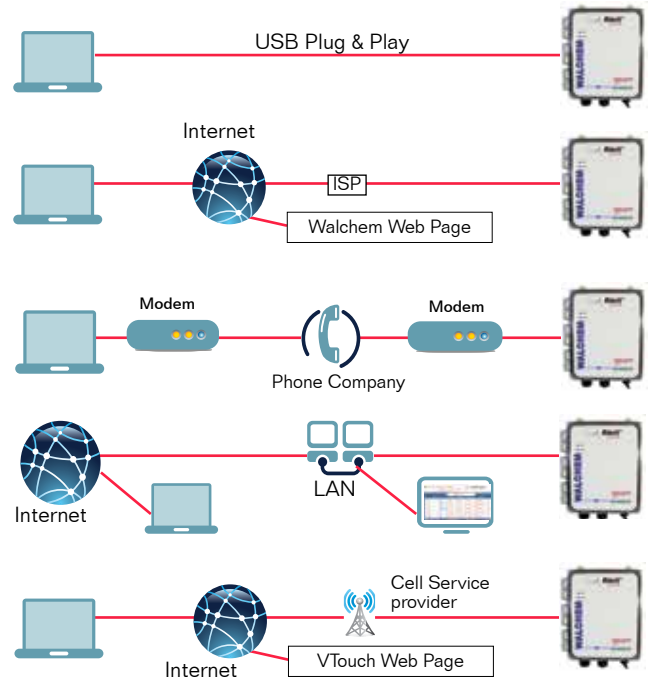

ETHERNET NETWORKING

By using the on-site Local Area Network (LAN) or by connecting the WebAlerts together via Ethernet, you can access all of the WebAlerts on a network from a single phone line or IP address. The "Master" WebAlert automatically detects the other WebAlerts and serves as a window to the "slaves" on the network, greatly reducing the cost and time associated with device configuration and running phone lines to each device. DHCP is supported to enable WebAlert to automatically obtain an IP address from the LAN.

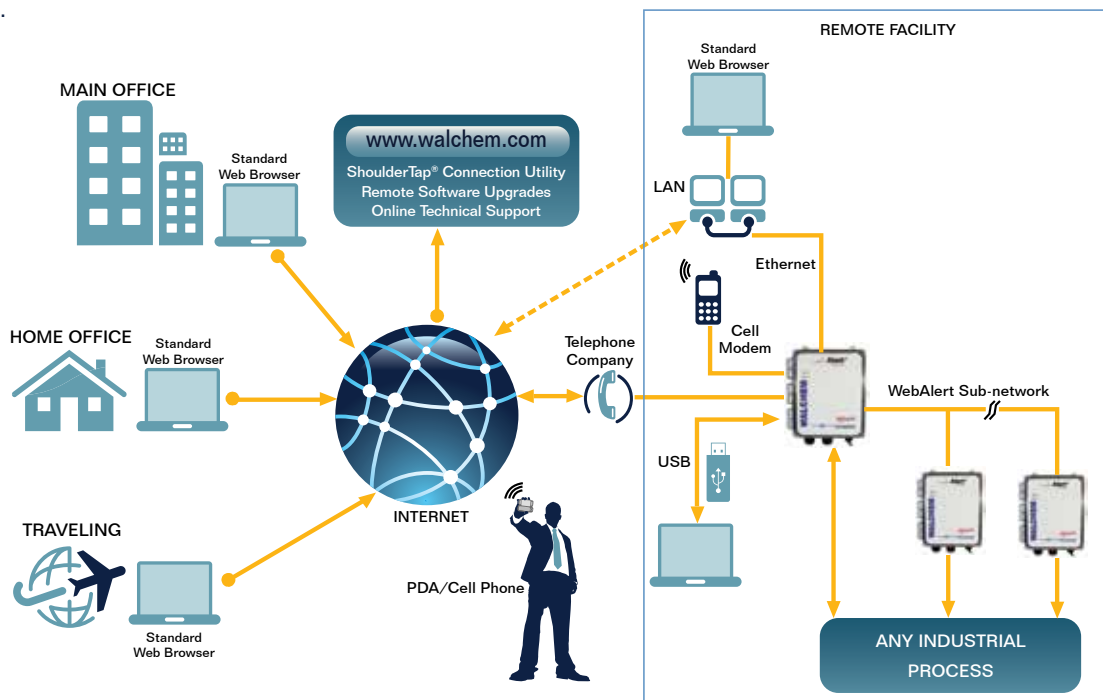

VTouch® Account Manager

'Smart' Service:

- On-line, web-based summary of account status
 - Process values continuously updated including past 24 hour min, max and average values
 - Alarm status
- One-click LIVE Connect to any device in the field for full view and reconfiguration
 - Analysis, troubleshooting, adjustments
- Seamlessly organize devices according to a process(es), facility, customer, etc.
- User "access" and "permissions" management
- Eliminates surprises during 'routine' visits
- Makes service PROACTIVE not reactive
- SAVES TIME! Plain & Simple

VTouch is a collection of technologies designed for companies offering managed water treatment services. The VTouch solution allows service companies to more effectively manage remote accounts by significantly reducing the complexities associated with the deployment of water treatment service programs based around communicating products.

The VTouch Account Manager is fully synchronized with Walchem's web based controllers, making set-up and configuration simple and fast. Just specify the type of remote communications needed for new or existing controllers and Walchem takes care of the rest. No need to sort out and track complicated and constantly moving cellular data or dial-up ISP plans from large companies with poor customer service and unpredictable monthly charges. VTouch solves these problems by bundling the communications services, giving you a completely turn-key solution.

The innovative, fully synchronized nature of VTouch provides you with a quick, centralized 24/7 awareness of account status with the ability to LIVE Connect to any of your controllers in the field with one simple mouse-click, regardless of connection type! No phone numbers or IP addresses to remember.

Summary view of all monitored systems

Custom named facility

Custom 'processes' defined for each facility

Critical process data, units & custom names sent from devices, synchronized automatically in VTouch. No lengthy set-up required!

One click and you connect LIVE to your device, regardless of connection type.

List Processes |

(System User)

ABC Industrial - Chiller Room

Tower #1 (Process Cooling)

Actions: [Settings] [Live Connect]

System Alarms: Level D (DI_D) Low Alarm (since 9/30/2011 1:23:09 PM)

Readings as of: 9/12/2012 10:06:54 AM

| Channel | Readings | | | | | Alarms |
|---------------------------|-----------------|---------------|----------------|----------------|----------------|--|
| Level 1 (AI_1) | Measure | | | | | None. |
| | 695.31 gal. | | | | | |
| FlowMeter4 (AI_4) | Total | Rate | Minimum | Maximum | Average | None. |
| | 21515344.00 gal | 69.78 gal/min | 69.71 gal/min | 70.06 gal/min | 69.82 gal/min | |
| Contact1 (DI_A) | Total | | | | | None. |
| | 0.00 gal. | | | | | |
| Flow Switch (DI_E) | State | | | | | None. |
| | FSClosed | | | | | |
| CLO2 1 (S_1) | Measure | | | | | None. |
| | 0.000 ppm | | | | | |
| HP 1000 (S_2) | Measure | | | | | High Alarm (since 6/24/2011 9:08:39 AM) |
| | 214 ppm | | | | | |
| en7 (S_3) | Measure | | | | | None. |
| | 55 mg/l | | | | | |

Ordering Information

WA500 — Wiring Comms Hardware Comms Software

WIRING

H = Hardwired, cable glands

P = USA power cord w/cable glands

COMMUNICATIONS (USB & ETHERNET STANDARD)

N = No additional communications

M = Modem card

G = Cellular modem card (GPRS)

COMMUNICATIONS SOFTWARE

N = None

1 = Ethernet Networking Master Capability



Webmaster®ONE

WebMasterONE is the most advanced online cooling tower and boiler controller in the water treatment industry. The flexible multi-I/O platform allows you to control multiple cooling towers, boilers, closed loops, and condensate lines with just one controller. An extensive assortment of integrated communications and data handling features are included that enable water treatment professionals to provide more effective water management services to their customers.



Metering Pumps

The E-Class is the most innovative and comprehensive metering pump product line in the world. Over 50 years of pump experience and a commitment to superior mechanical design has led to development of many industry firsts, including 360 stroke-per-minute technology, IP67 waterproof construction, and the world's highest capacity solenoid metering pumps.



WIND WebMaster® Industrial Water Controllers

Walchem's WebMaster Industrial (WIND) Controller sets a new standard for Industrial Water Treatment Controllers. WIND has a flexible multi-I/O platform, a wide range of analytical sensor measurement capabilities, and an extensive assortment of integrated communications and data handling features.



WebAlert Remote Monitor

Walchem's WebAlert is the first stand alone remote monitoring device that can web enable your installed equipment without having to replace or upgrade it.



ABOUT US

Walchem integrates its advanced sensing, instrumentation, fluid pumping and communications technologies to deliver reliable and innovative solutions to the global water treatment market.

Our in-house engineering is driven by quality, technology and innovation. For more information on the entire Walchem product line, visit: www.walchem.com.