

HG

WATERPROOF HALOGEN SPOT LIGHT

FEATURES:

- Halogen industrial task light designed for large machining areas
- Available in waterproof (HGW & HGWK) and non-waterproof models (HG)
- Low voltage models require only 24V supplied to the lamp, improving operator safety
- 120V versions include a remote transformer in waterproof case for plug-in 120V operation
- Extruded aluminum ergonomic handle and heat shield provide safe, easy positioning
- 3 adjustable positioning axes for head
- 5in head with side connection strain reliefs and terminal block, insure easy installation
- Optional transformers are available either alone or mounted inside waterproof cases
- 4-hole mounting base included
- 12V models are available. Please contact Customer Service for additional information.

SPECIFICATIONS:

Voltage	24V or 120V, 50/60Hz
Lamping	H3 halogen
Luminaire Body	extruded aluminum head, steel arm
Operation	models available with or without switch
Lens Cover	borosilicate glass
Protection Rating	HG - IP20
	HGW - IP65 w/switch
	HGW - IP67 without switch
Cord Length	none; direct power supply
Mounting and accessories	See page 63



When a powerful halogen spot light is required on machinery, Waldmann halogen luminaires are the perfect solution. The HG and HGW Series of halogen luminaires offer a concentrated, intense light beam for your larger machining areas. The ingenious anti-glare louver in the HG and HGW head prevents glare from bothering co-workers. The HGW-70 machine light is the high powered solution for work areas requiring an intense light over longer distances. The 32" arm is available for maximum positioning. The 18" arm may be used in areas with less space. Both models include a double lens for heat reduction. The waterproof pivoting head version of our powerful HGW halogen series provides an intense light source where space is limited under harsh conditions.

DIMENSIONAL DATA

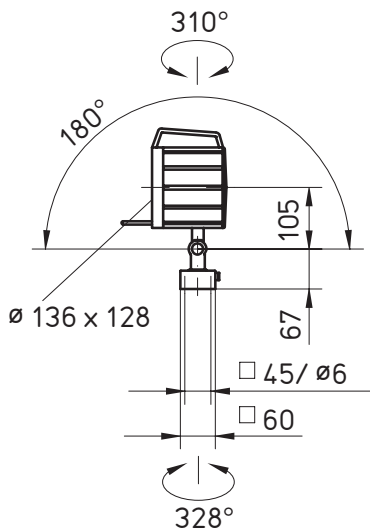

HGWK Pivoting Head

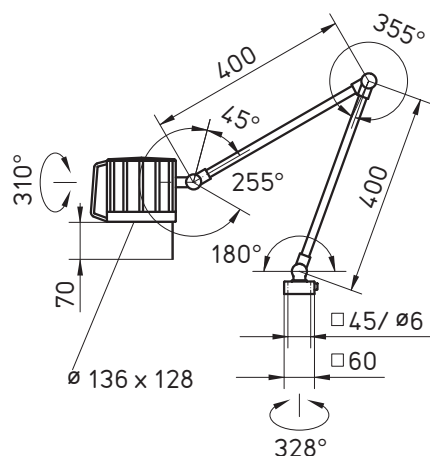

HGW Articulating Arm

Measurements in millimeters

ORDERING INFORMATION

Description	Voltage	Arm Reach	IP Rating	Transformer Incl.	Switch Incl.	Model	Part #
Pivoting head	24V	na	IP67	No	No	HGWK-70	008 308 800
Pivoting head	24V	na	IP65	No	Yes	HGWK-70	008 308 802
Pivoting head	120V	na	IP65	Yes	Yes	HGWK-70	008 308 806
Articulating arm	24V	18" reach	IP65	No	Yes	HGW-70	100 870 801
Articulating arm	24V	32" reach	IP65	No	Yes	HGW-70	100 870 803
Articulating arm	120V	18" reach	IP65	Yes	Yes	HGW-70	108 870 801
Articulating arm	120V	32" reach	IP65	Yes	Yes	HGW-70	108 870 802

Mounting Options	Item	Dimensions	Part #
	Table clamp	0" - 2.75" span	190 007 019 - 000 149 04
	Table clamp	2.5" - 5.4" span	190 033 019 - 000 149 50
	Wall bracket	2.4" x 2.8"	300 213 018 - 000 251 78

Accessories	Item	Type	Finish	For Use With:	Part #
	Transformer	60VA, 120V	Enclosed w/case	24V fixtures	150 127 M19
	Transformer	60VA, 120V	W/out case	24V fixtures	150 125 M19
	Transformer	60VA, 230V	W/out case	24V fixtures	150 048 019 - 000 146 31

Replacement Lamp	Item	Type	Lens Finish	For Use With:	Part #
	Halogen lamp	H3, 60W	n/a	24V and 120V fixtures	450 070 300 - 000 415 40
	Halogen lamp	H3, 55W	n/a	12V fixtures	450 055 300
	Replacement lens	Hardened glass	Clear	na	305 412 010 - 000 295 13
	Replacement lens	Hardened glass	Frosted	na	305 412 020 - 000 295 15
	Replacement lens	Tempered glass	Clear	na	305 412 030