

Wall Industries, Inc.

SP48S3.3-66

66W DC-DC Converter
36-75 Vdc Input
3.3 Vdc Output at 20A
Half-Brick Package

**Features:**

- **80% Efficient at Full Load**
- **Fast Transient Response**
- **Operation to No Load**
- **100% Burn In**
- **Remote ON/OFF (Active High/Low)**
- **Remote Sense Compensation**
- **UL 1950 Listed - CE Mark**
- **Low Output Ripple**
- **Fixed Switching Frequency**
- **Output Over Current Protection**
- **Output Short Circuit Protection**
- **Over Temperature Protection**
- **1500 Vdc Isolation**
- **Test Board Available**

Description:

The SP & SPW series is a high-density half brick converter that incorporates the desired features required in today's demanding applications. When performance, reliability, and low cost are needed, the SP & SPW series delivers.

WALL INDUSTRIES, INC.

APPLICATION NOTES SP & SPW SERIES

Technical Specifications		Model No. SP48S3.3-66			
All specifications are based on 25C, Nominal Line and Full Load unless otherwise noted. We reserve the right to change specifications based on technological advances.					
SPECIFICATION	Related condition				Unit Measured
		MIN	NOM	MAX	
INPUT					
Turn on at			34		Volt DC
Turn off at			32		Volt DC
Input Over voltage Shutdown					
Turn off at			78		Volt DC
Turn on at			77		Volt DC
Operating Voltage Range	Rated Input Voltage	36	48	75	Volt DC
Maximum Input Current	Low Line 100% load		2.283		A
No Load Input Current			25		mA
Input Current under "LOGIC OFF"			2		mA
Inrush Current Transient Rating					A ² Sec
Reflected Ripple Current			20		mA
OUTPUT					
Output Voltage Set point		3.267	3.300	3.333	Volt DC
Output Voltage Regulation					
Over Load				0.1	%
Over Line				0.1	%
Over Temperature				0.02	% / °C
Output Voltage Ripple and Noise					
Basic Ripple					mV
Spikes P-P				50	mV
Output Current Ranges	Rated Output Current	0		20	A
Output Current Limit		24	28	32	A
Short Term Output Current Surge					A/sec
DYNAMIC CHARACTERISTICS					
Input Voltage Ripple Rejection	120 Hz				dB
Output Transient and Load Changes					
Load step / delta V	X 50 to 75%		50 to 100%	250	mV
Load step / delta V	X 75 to 50%		100 to 50 %	250	mV
Recovery Time	To within 1% Rated Vo			100	µsec
Turn on Delay	From Vin(nom) to 90% Vout (nom)			250	M sec
Overshoot of Output Voltage	Full Load Resistive			0	%
EFFICIENCY					
@ 100% load			80		%
@ 75% load			81		%
@ 50% load			82		%
@ 25% load			80		%
TEMPERATURE CONSIDERATIONS					
Thermal Resistance					
Normal Convection	Rtheta c-a		7.5		°C/Watt
100 lfm			6.2		°C/Watt
200 lfm			5.1		°C/Watt
300 lfm			4.3		°C/Watt
400 lfm			3.5		°C/Watt
Heatsink Considerations	Contact Factory				
General Technical Data					
Switching Frequency	FIXED		400		KHz
Remote ON OFF Control <i>(See Note Below)</i>	Positive or Negative				
Trimmability					
Over Temperature Shutdown	Case Temperature		105		°C
MTBF					
	Bellcore TR-332 nom is 2.50m				Hours

Note: Positive Remote ON/OFF control is standard. To order negative logic Remote ON/OFF control add the suffix "R" to the part number.

Figure 1: Mechanical Dimensions

Unit: inches

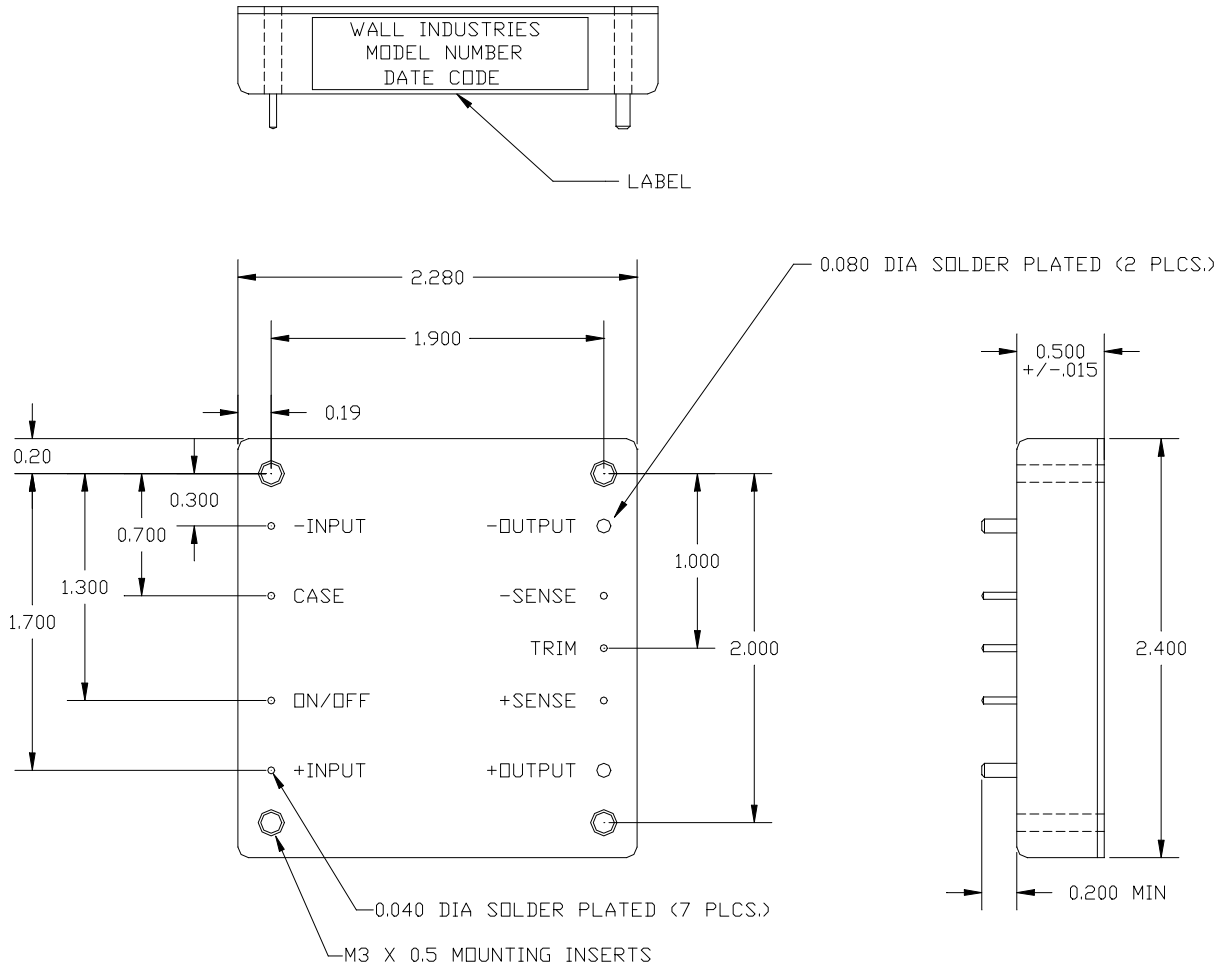

Tolerance: X.XX ± 0.020
 X.XXX ± 0.010

Output Voltage Trim

The following information is provided to allow quick calculation of the trim resistor value for a desired output voltage. The general procedure for calculating a trim resistor is as follows:

1. Determine the desired output voltage (Vo)
2. Select Equation. (Trim Low/Trim High)
3. Use the data in Table 1 to complete the equation.
4. Evaluate.

In order to trim low use Equation 1 and Table 1 to calculate resistor RTL for the desired output voltage.

Equation 1: Trim Low

$$RT_L = \left[\frac{V_o - V_{REF}}{\left(\frac{V_{REF}}{R_L}\right) - \left(\frac{1}{R_H} \cdot (V_o - V_{REF})\right)} \right] - R_{LIM}$$

*Vo - Desired output voltage.
 All resistor values in K ohms.*

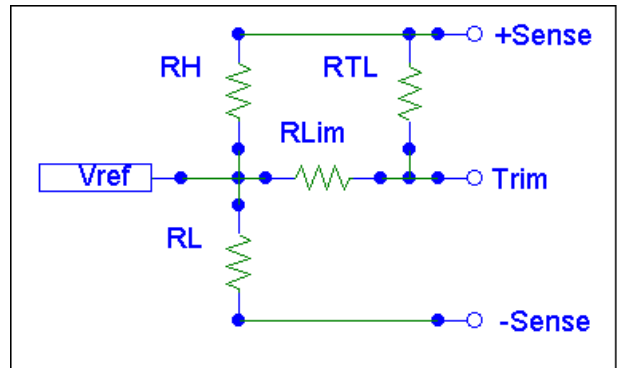

Schematic 1: Trim Low

In order to trim high use Equation 2 and Table 1 to calculate resistor RTH for the desired output voltage.

Equation 2: Trim High

$$RT_H = \left[\frac{V_{REF}}{\left(\frac{V_o - V_{REF}}{R_H}\right) - \left(\frac{V_{REF}}{R_L}\right)} \right] - R_{LIM}$$

*Vo - Desired output voltage.
 All resistor values in K ohms.*

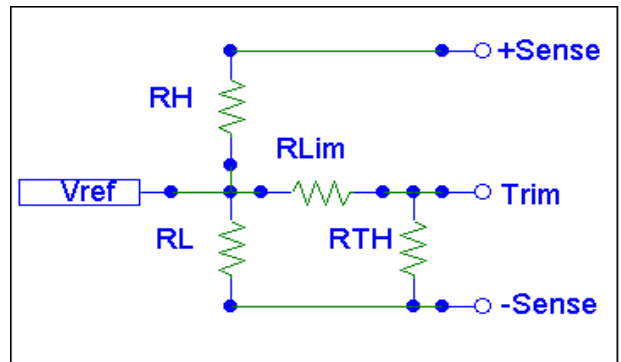

Schematic 2: Trim High

MODEL (Output Voltage)	R _H (K OHMS)	R _{LIM} (K OHMS)	R _L (K OHMS)	V _{REF} (VOLTS)
3.3V	0.750	0.499	2.32	2.495
5.0V	2.49	10.0	2.49	2.495
8.0V	5.49	10.0	2.49	2.495
9.0V	6.49	10.0	2.49	2.495
12.0V	9.53	13.7	2.49	2.495
15.0V	12.4	13.7	2.49	2.495
24.0V	21.5	15.4	2.49	2.495
26.0V	17.6	15.4	1.87	2.495
32.0V	23.7	12.7	2.00	2.495

Table 1 : Trim Low/High Data Table.

Note: Output trim +/- 10% max.

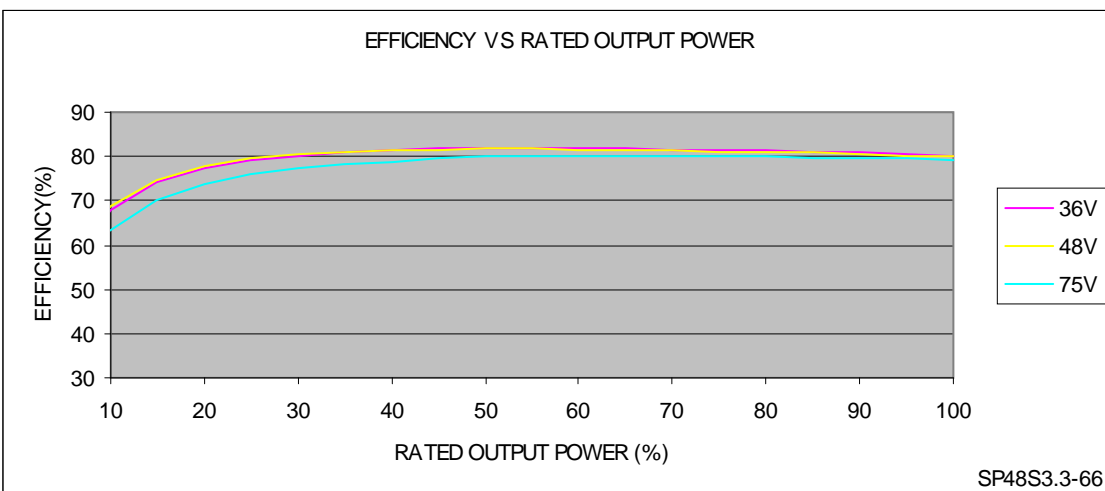
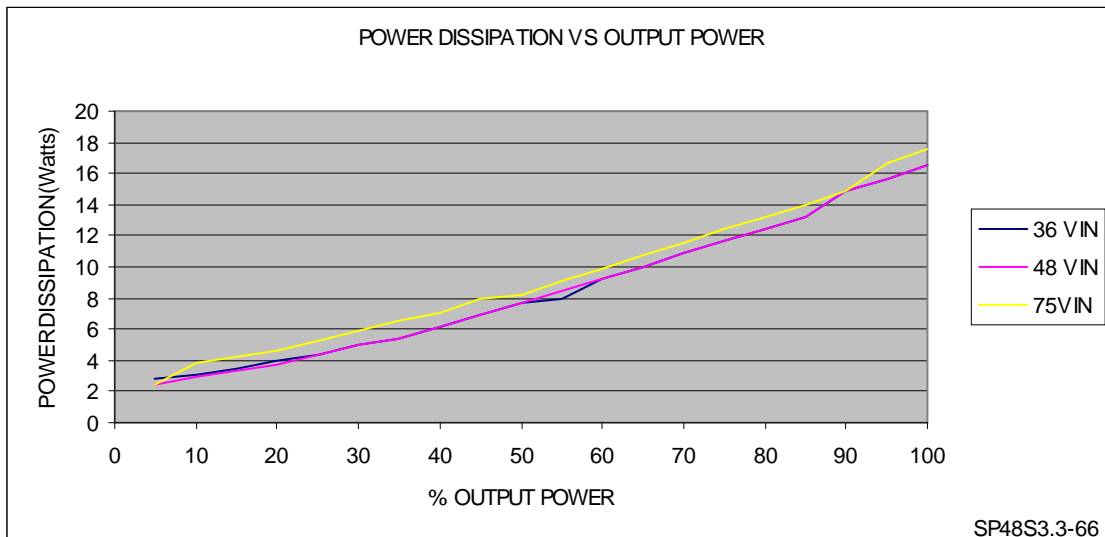
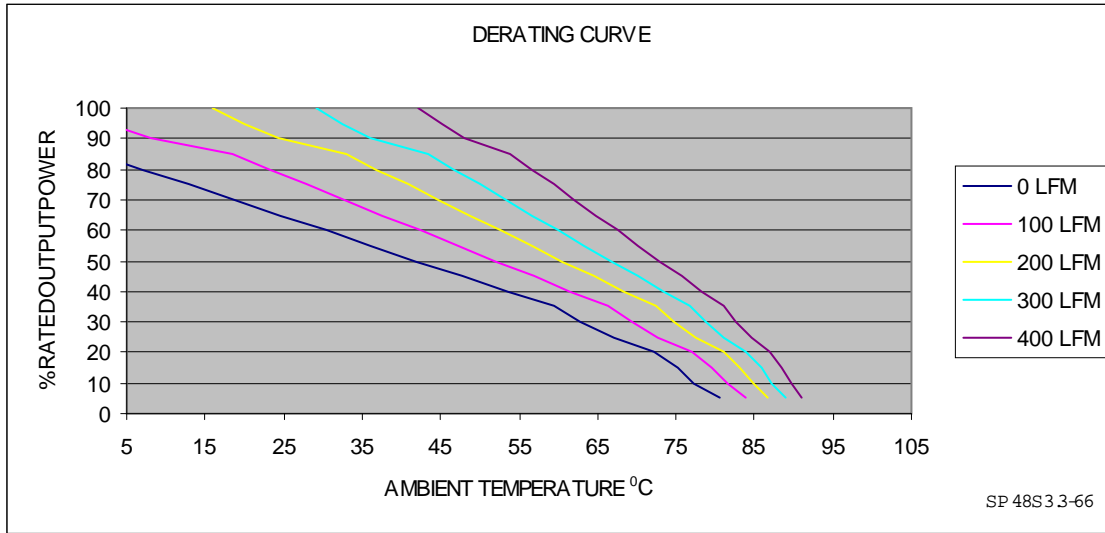

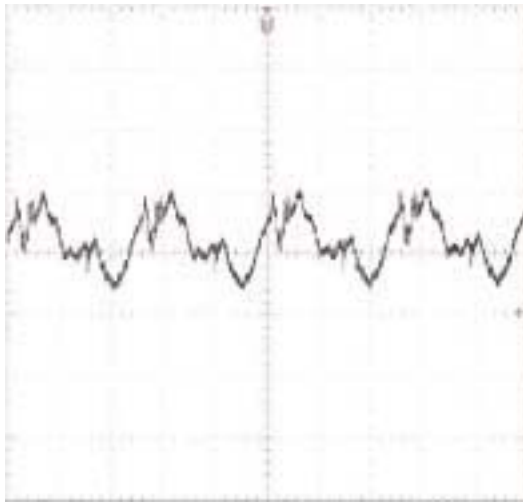

TYPICAL OUTPUT RIPPLE VOLTAGE
20mV/div, 2 us/div, full load 48 vin 10 uF
decoupling cap. Room temperature.

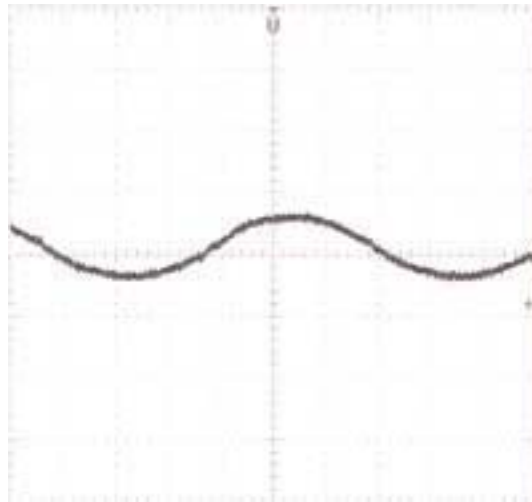

TYPICAL INPUT REFLECTED RIPPLE CURRENT
20mA/div, full load 48 vin.(using 12uH, 33uF (low ESR)
source impedance). Room temperature.

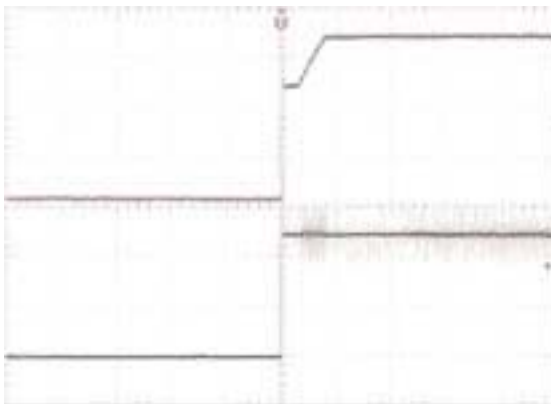

TYPICAL RISE TIME AND TURN ON DELAY
USING LOGIC ENABLE
1 V/div, 10 mS/div, (vout) 2 V/div, 10 mS/div
(logic enable) 48 vin, full load. Room temperature.

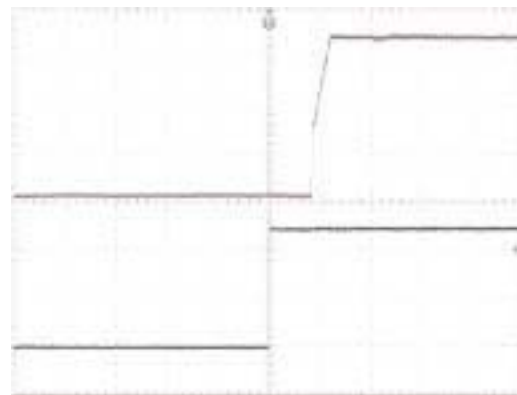

TYPICAL RISE TIME AND TURN ON DELAY
WITH VIN 0-48V
1V/div, 10 mS/div, (vout) 20 V/div 10 mS/div (vin)
48 vin full load. Room temperature.

SP48S3.3-66

Ordering Information:

Part Number Example:

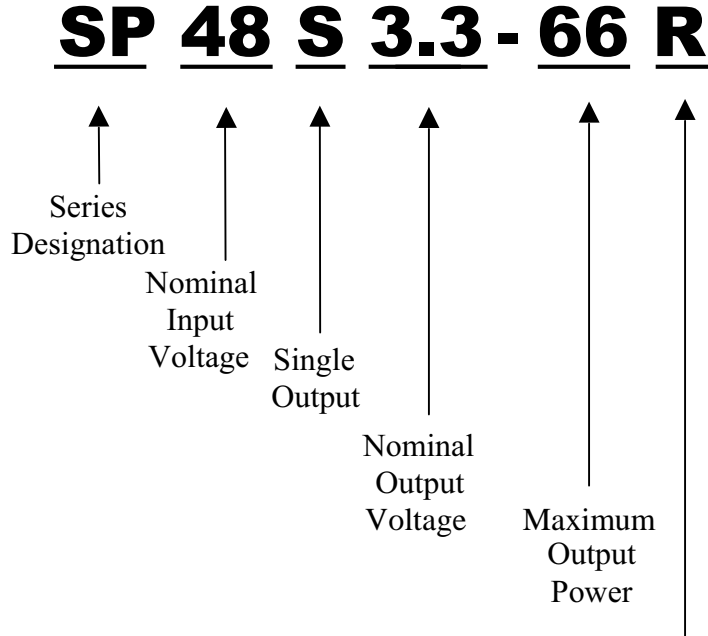

Options	
Blank	Leave Blank for Active High Enable
R	Active Low Enable

Company Information:

Wall Industries, Inc. has created custom and modified units for over 40 years. Our in-house research and development engineers will provide a solution that exceeds your performance requirements on time and on budget. Our ISO9001-2000 certification is just one example of our commitment to producing a high quality, well documented product for our customers.

Our past projects demonstrate our commitment to you, our customer. Wall Industries, Inc. has a reputation for working closely with its customers to ensure each solution meets or exceeds form, fit and function requirements. We will continue to provide ongoing support for your project above and beyond the design and production phases. Give us a call today to discuss your future projects.

Contact **Wall Industries** for further information:

Phone: ☎ (603)778-2300
Toll Free: ☎ (888)587-9255
Fax: ☎ (603)778-9797
E-mail: sales@wallindustries.com
Web: www.wallindustries.com
Address: 5 Watson Brook Rd.
 Exeter, NH 03833