

BA, D2, SM/SMA & SMC Connectors

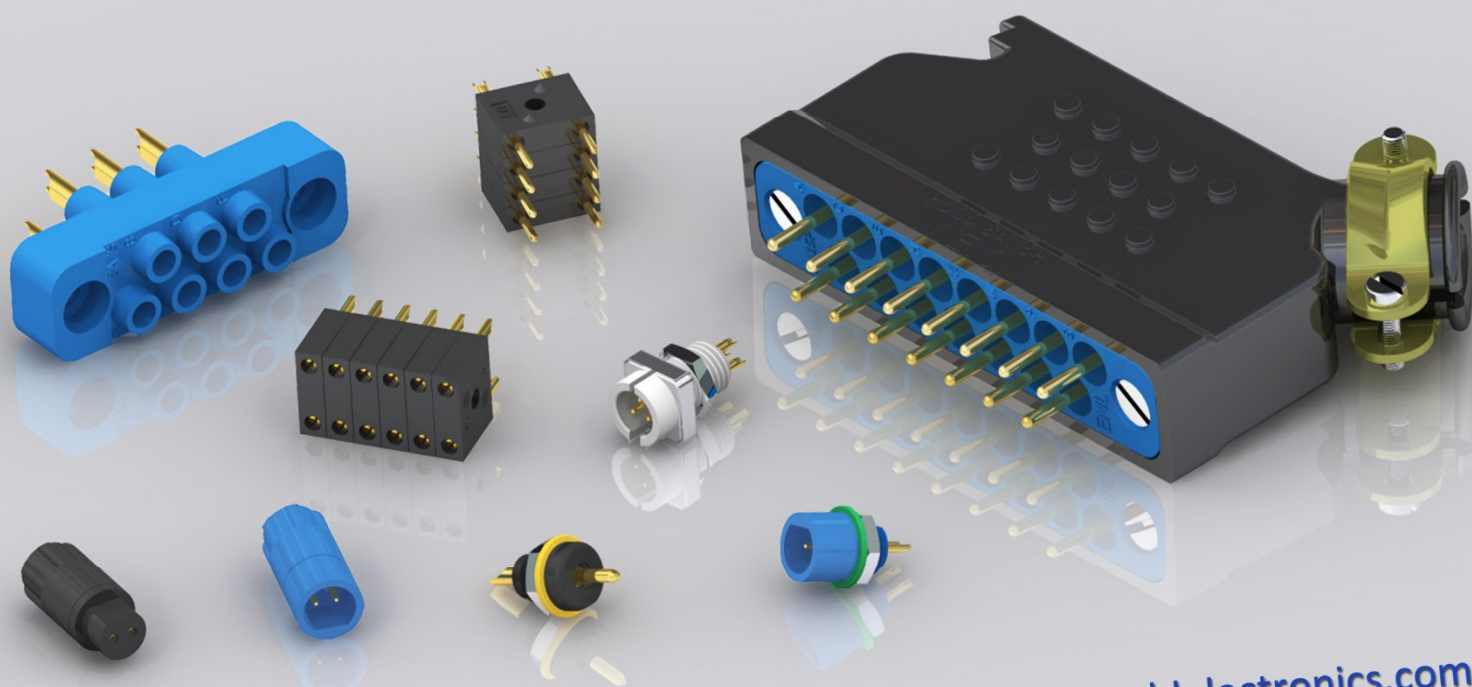

www.wealdelectronics.com

Weald
ELECTRONICS

MANUFACTURERS OF HIGH QUALITY MILITARY CIRCULAR CONNECTORS

**BA, D2, SM/SMA & SMC RANGE
CONTENTS****General information****D2 RANGE - MINIATURE STACKABLE 2-POLE CONNECTOR UNITS**

General description	3
Characteristics	3
Basic dimensions	4
Ordering information	4

SM/SMA RANGE - CONNECTORS WITH 1, 2 & 3 CONTACTS

General description	5
Characteristics	5
Basic dimensions	6
Ordering information	6

BA RANGE - HIGH VOLTAGE CONNECTORS WITH 7 OR 15 CONTACTS

General description	7
Characteristics	7
Basic dimensions – connector	8
Basic dimensions – hood	9
Ordering information	9

SMC RANGE - SUB-MINIATURE 3-WAY CONNECTORS

General description	10
Characteristics	10
Basic dimensions	11
Ordering information	11

Product safety information	12
----------------------------------	----

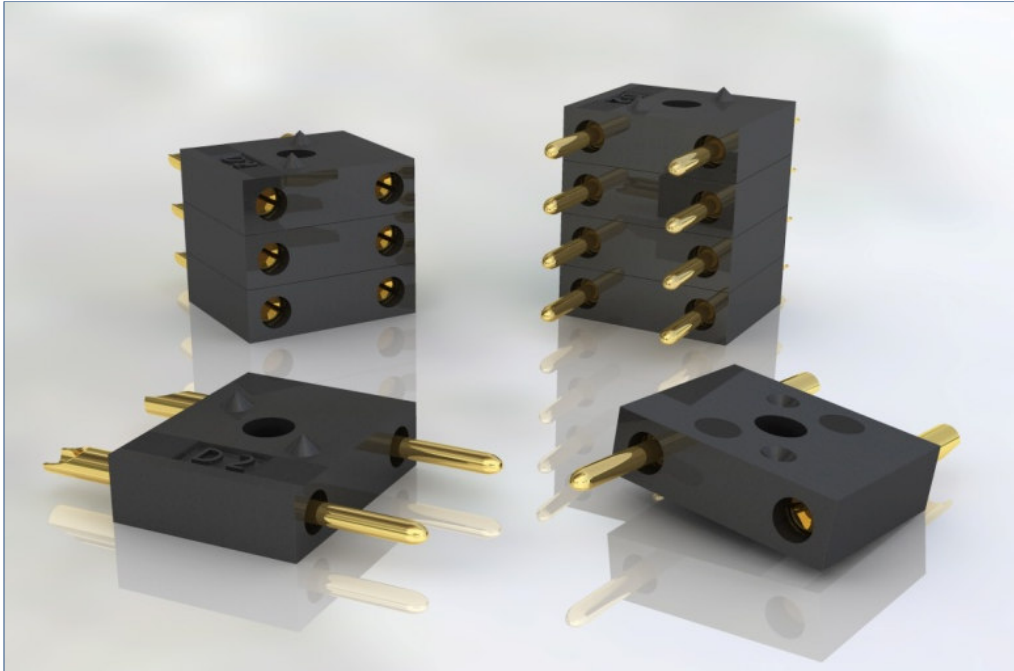
**D2 RANGE
MINIATURE STACKABLE 2-POLE CONNECTOR UNITS****GENERAL DESCRIPTION**

The basic unit can be supplied as a double-contact plug, a double-contact socket, or as a connector unit with one pin and one socket. Units can be stacked together and secured by a single M2 bolt or stud through the central hole to form a polarised multi contact connector of a size to suit local requirements. Locating pips on the mouldings prevent the stacked units from twisting.

CHARACTERISTICS

Temperature range	-40° to +125°C	
Number of contacts	2	
Current rating per contact	5 amps	
Working voltage	450V DC or AC peak at sea level	
D.C. breakdown voltage	Sea Level	60,000 ft
Between contacts	3300V	800V
Contacts to ground	1800V	360V
Contact solder bucket diameter	1,15mm	
Contact material	Plug	Socket
	Brass	Phosphor bronze
Contact spacing	7,62mm	
Contact plating	Gold over nickel	
Moulding material	Nylon	

**D2 RANGE
MINIATURE STACKABLE 2-POLE CONNECTOR UNITS**

BASIC DIMENSIONS

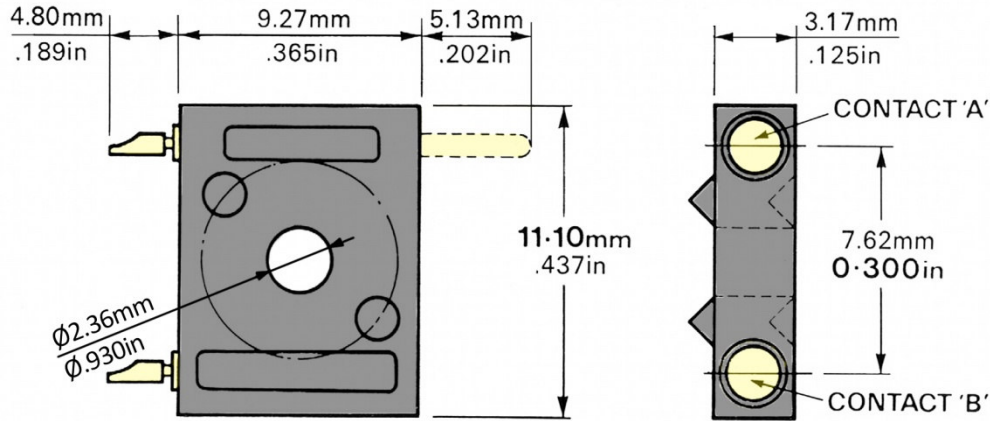

All outline dimensions are nominal.

ORDERING INFORMATION

Specify connector as follows:

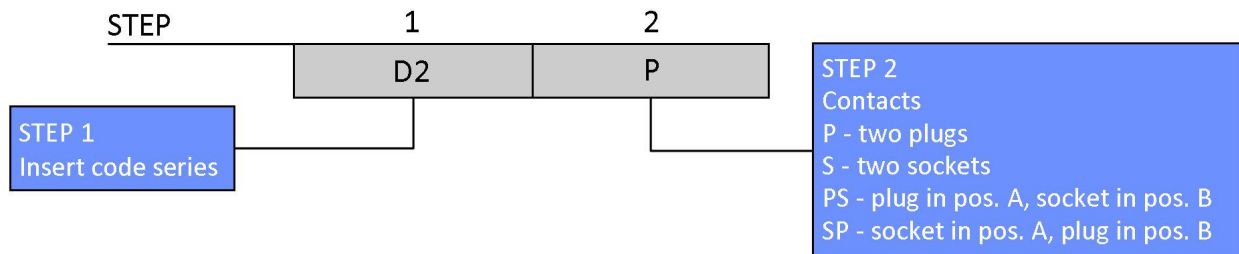

D2 Range connectors are sold in packets of 10 connectors per packet

**SM/SMA RANGE
CONNECTORS WITH 1, 2 & 3 CONTACTS**

GENERAL DESCRIPTION



A range of robust sub-miniature connectors for limited space use in test & measurement, prototyping, educational laboratory, portable equipment and instrumentation applications. The mouldings are of PBT which gives the range high arc resistance and high dielectric and mechanical strength. The spring-tempered, brass contacts are gold plated for low contact resistance, easy soldering and proof against corrosion. Either plug or socket can be mounted to chassis or bulkhead and there is a choice of six coloured discs for identification purposes. The connector hoods, illustrated, are equally suitable for plugs or sockets. The connectors can be supplied in black or blue.

CHARACTERISTICS

Total No. of Contacts	Plug Code No.	Socket Code No.	Solder Cup Hole dia. [mm]	Current Rating [Amps]	D.C. Voltage Breakdown (Connector engaged)	
					Between contacts	Contacts to ground
1	SMA1P	SMA1S	1.60	12	-	5000
1	SM1P	SM1S	1.10	7	-	5400
2	SM2P	SM2S	0.56	3	1600	2600
3	SM3P	SM3S	0.56	3	1500	2600
Body and hood material				PBT (polybutylene terephthalate)		
Contact material				Gold plated brass		
Identity disc material				Rigid PVC		
Identity disc colours				red, white, black, blue, green, yellow		
Temperature range				-55°C to 125°C		

SM/SMA RANGE CONNECTORS WITH 1, 2 & 3 CONTACTS

ORDERING INFORMATION

Specify complete plug or socket by following Steps 1 through 5. Omit steps not required.

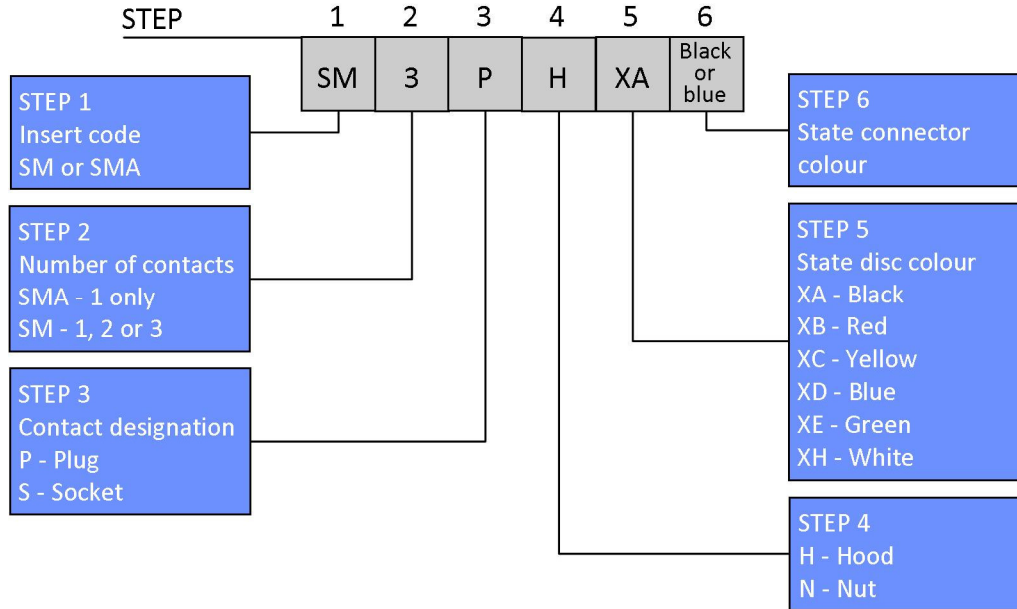

BASIC DIMENSIONS

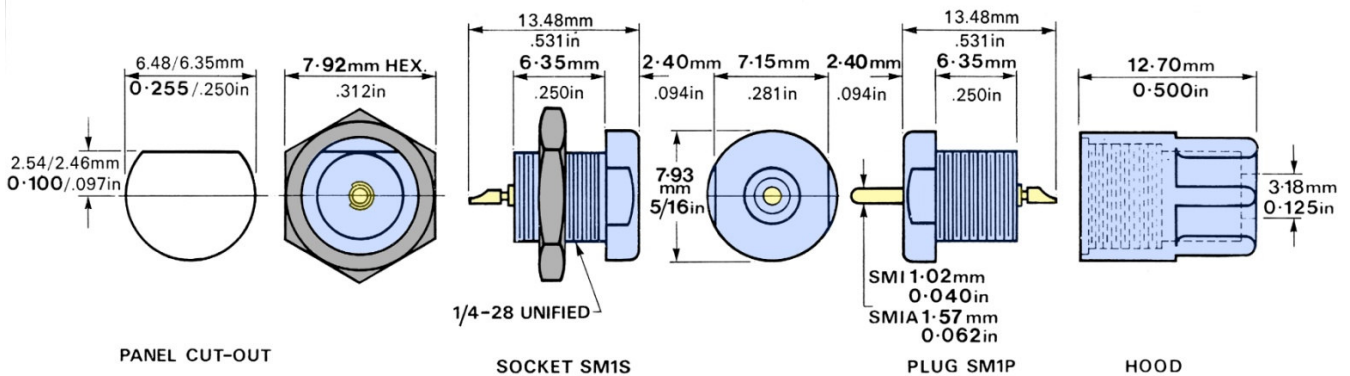

General outline drawing for SM1 and SMA1 connectors

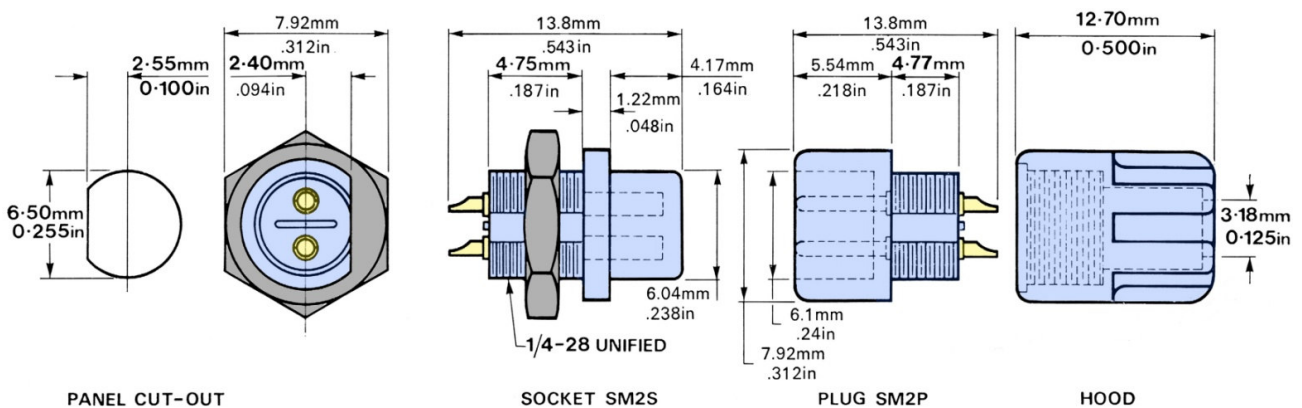

General outline drawing for SM2 and SM3 connectors (SM2 shown)

All outline dimensions are nominal.

BA RANGE
HIGH VOLTAGE CONNECTORS WITH 7 OR 15 CONTACTS 1,57mm DIA.

GENERAL DESCRIPTION

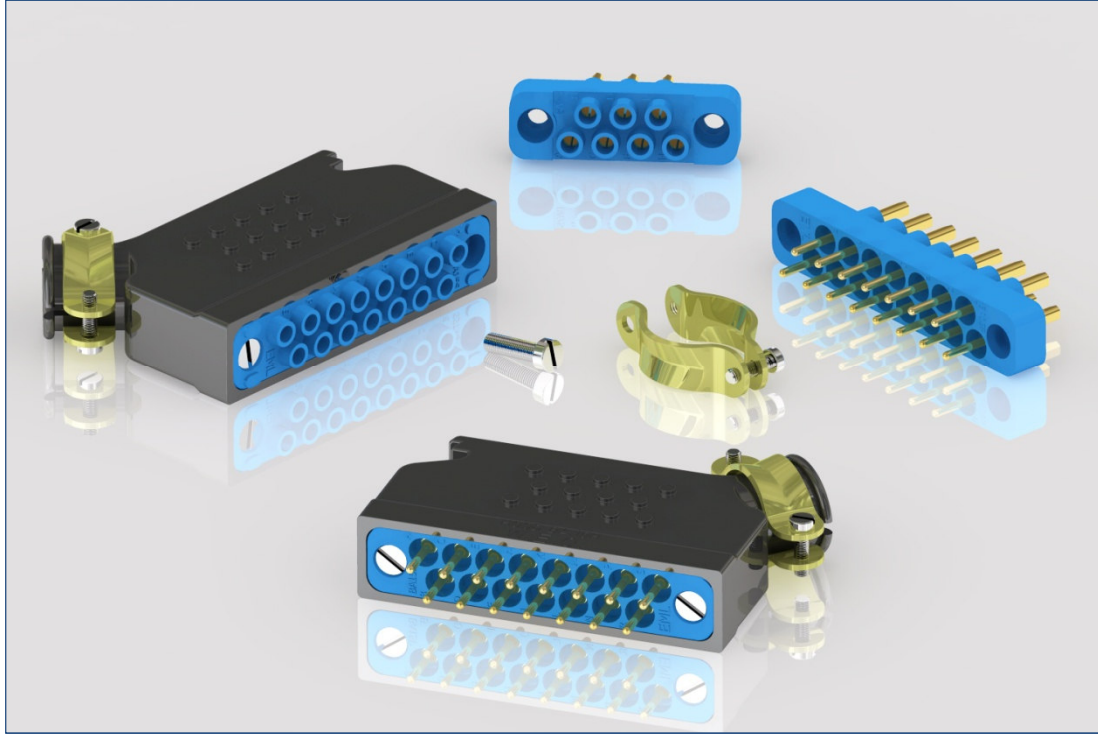

The extremely compact lightweight construction of these high voltage plug and socket connectors makes them ideal for use in power control and communications circuits. D.A.P. mouldings provide high arc resistance, and high dielectric and mechanical strength. The non-rotating contacts are gold plated to provide low contact resistance, to prevent corrosion and to facilitate soldering.

CHARACTERISTICS

Current rating per contact	13A	
D.C. breakdown voltage (connector engaged)	Sea Level	60,000 ft
Between contacts	7000V	1700V
Contacts to ground	10000V	1700V
Solder cup hole dia.	1.85 mm	
Working voltage (see level)	2.5kV DC or AC peak	

**BA RANGE
HIGH VOLTAGE CONNECTORS WITH 7 OR 15 CONTACTS 1,57mm DIA.**

BASIC DIMENSIONS

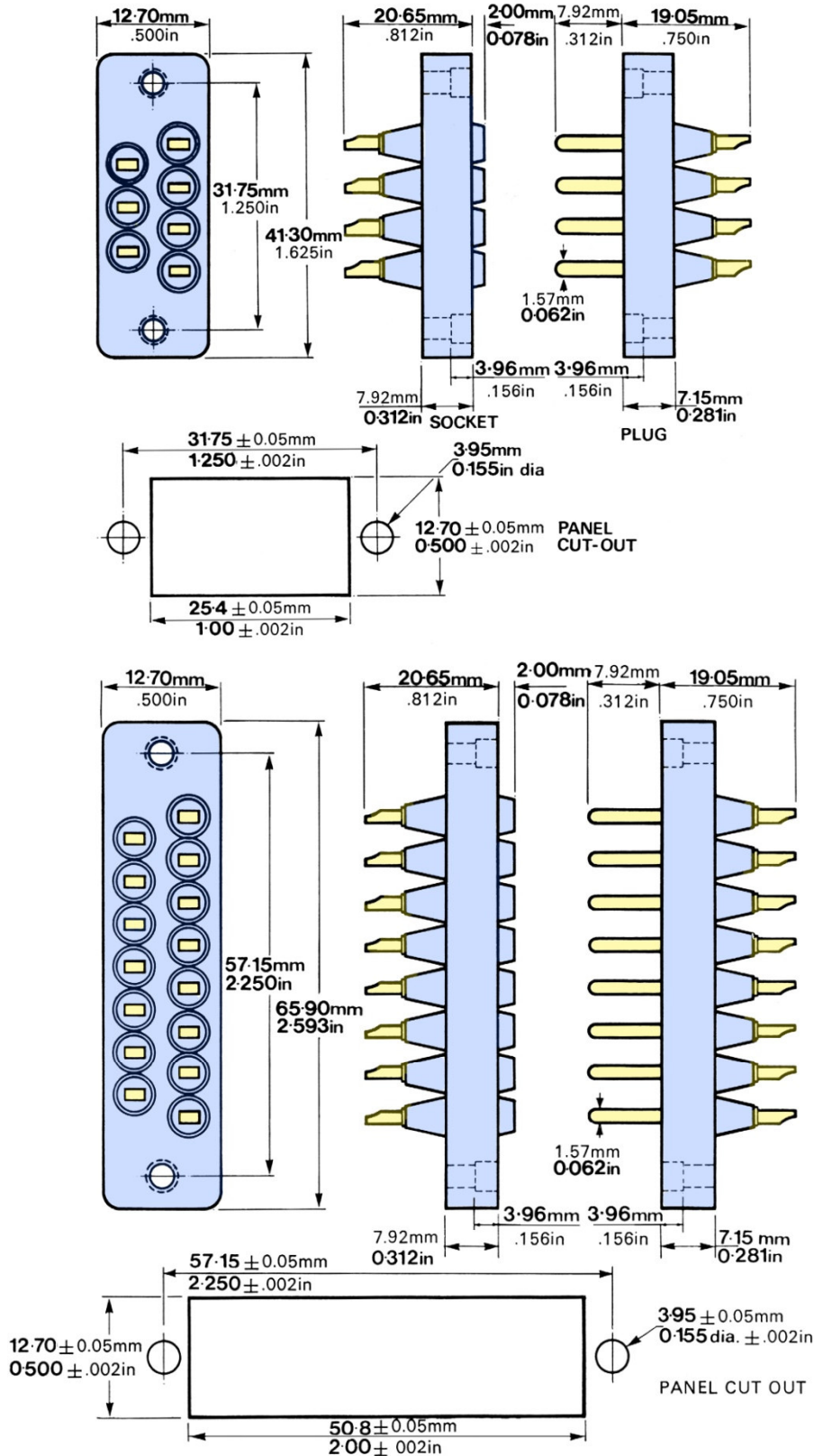

All outline dimensions are nominal.

**BA RANGE
HIGH VOLTAGE CONNECTORS WITH 7 OR 15 CONTACTS 1,57mm DIA.**

HOOD DIMENSIONS

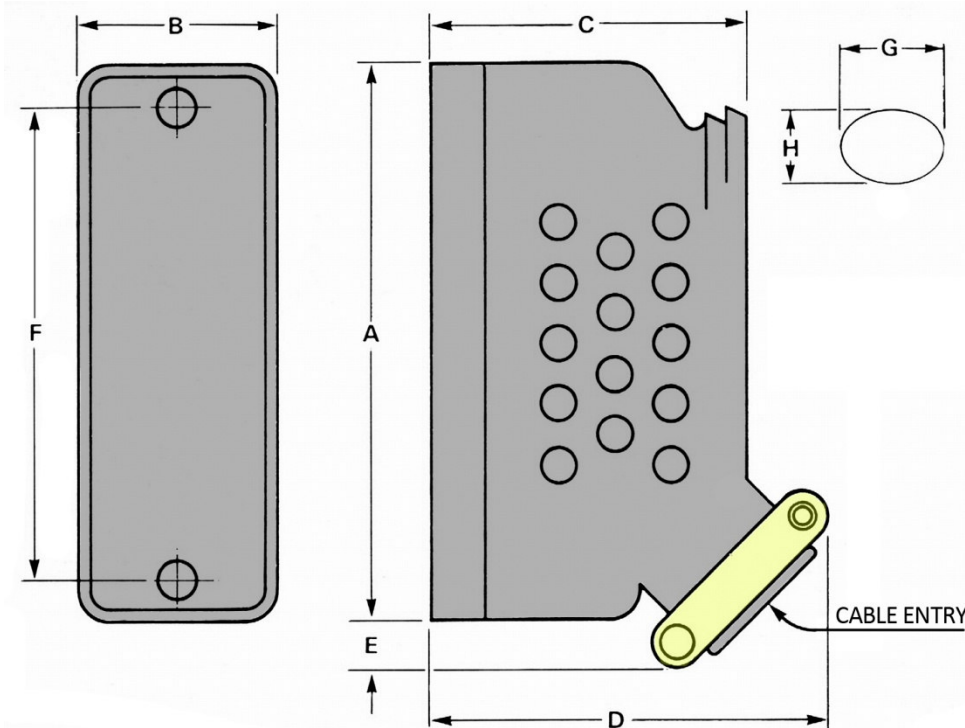

Material:
High density polythene

Designed to protect the soldered wire connections on plugs and sockets. They render support and strain relief to the cable and facilitate disengagement of mated connectors.

All outline dimensions are nominal.

FITS CONNECTOR		A	B	C	D	E	F	G	H
7 way	in	1.765	0.640	1.250	2.00	0.250	1.250	0.375	0.281
	mm	44.83	16.27	31.75	50.80	6.35	31.75	9.53	7.14
15 way	in	2.734	0.640	1.500	2.125	0.375	2.250	0.562	0.406
	mm	69.45	16.27	38.10	53.90	9.53	57.15	14.27	10.31

ORDERING INFORMATION

Specify complete plug or socket by following Steps 1 through 4. Omit steps not required.
If hoods only required, complete Steps 1, 2 and 4 only.

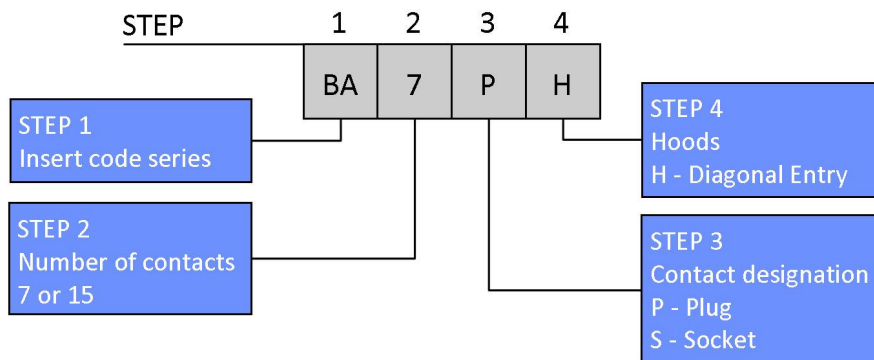

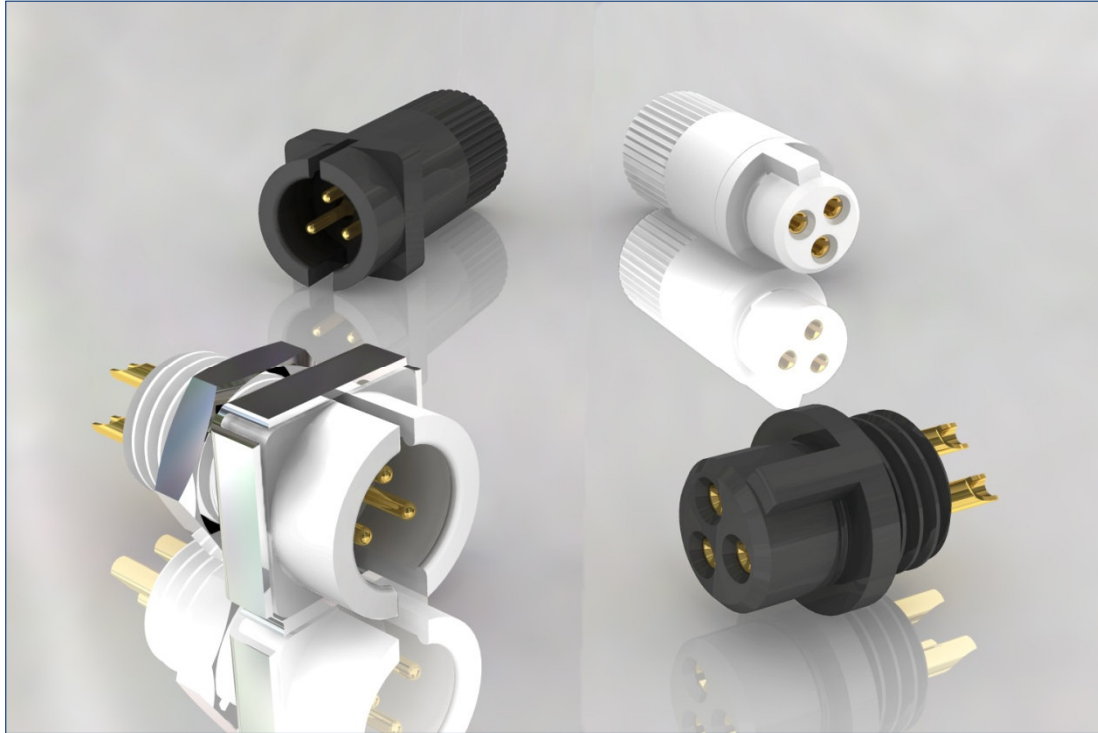
**SMC RANGE
SUB-MINIATURE 3-WAY CONNECTORS****GENERAL DESCRIPTION**

An extremely compact sub-miniature 3-way connector available in black or white, suitable for panel mounting or as a free link. Plug and socket mouldings are of low density polyethylene. These connectors snap together firmly and are fully polarised. When used as a free link, hoods should be fitted to both plug and socket.

Contacts are supplied loose and should be inserted after soldering.

CHARACTERISTICS

Current rating per contact	3A	
D.C. breakdown voltage (connector engaged)	Sea Level	60,000 ft
Between contacts	1700V	900V
Contacts to ground	3800V	900V
Contact resistance per contact	5 mΩ	
Solder cup hole dia.	0.79 mm	
Colour	black or white	
Body and hood material	LDPE (low density polyethylene)	
Contact material	Gold plated brass	
Temperature range	-51°C to 70°C	

**SMC RANGE
SUB-MINIATURE 3-WAY CONNECTORS**

BASIC DIMENSIONS

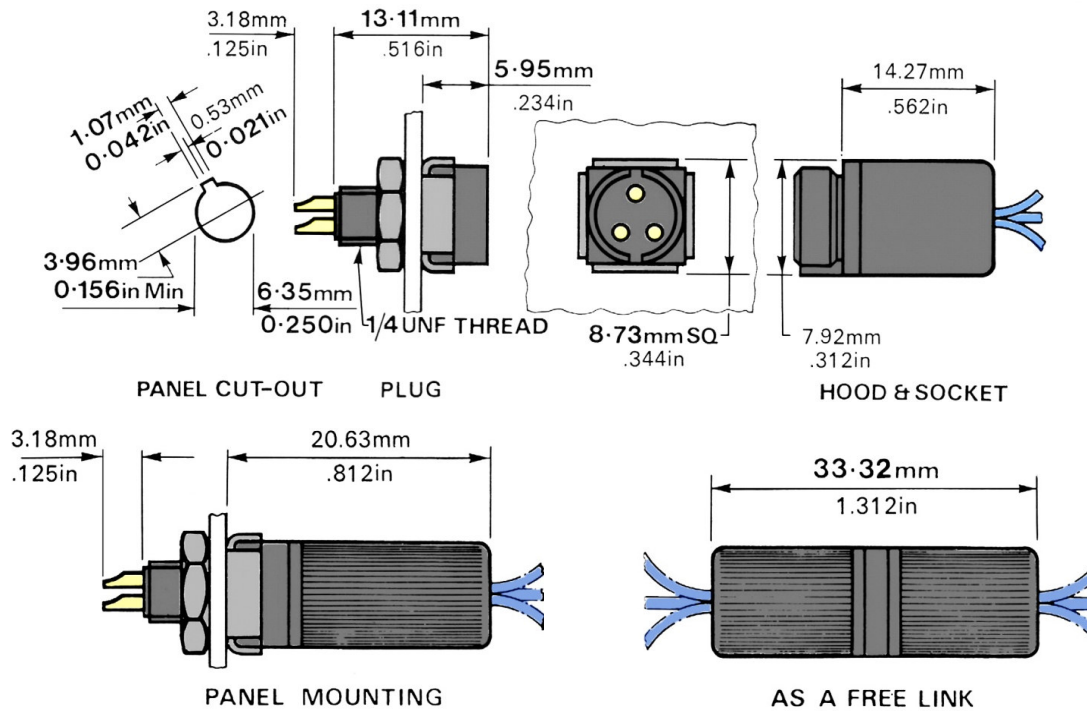

All outline dimensions are nominal.

ORDERING INFORMATION

Set Part No.	Colour	Plug Moulding	Socket Moulding	Hood	Pin Contact	Socket Contact	Retaining Washer	Hexagon Nut	Contents of Set Assemblies
SMC310	White	1	1	1	3	3	1	1	
SMC340	Black	1	1	1	3	3	1	1	
SMC31A	White	1	1	2	3	3	1	1	
SMC34A	Black	1	1	2	3	3	1	1	
SMC31B	White	1	-	1	3	-	-	-	
SMC34B	Black	1	-	1	3	-	-	-	
SMC31C	White	-	1	1	-	3	-	-	
SMC34C	Black	-	1	1	-	3	-	-	
SMC31D	White	1	1	1	3	3	-	-	
SMC34D	Black	1	1	1	3	3	-	-	
SMC31E	White	1	-	-	3	-	1	1	
SMC34E	Black	1	-	-	3	-	1	1	
SMC31F	White	-	1	-	-	3	1	1	
SMC34F	Black	-	1	-	-	3	1	1	

PRODUCT SAFETY

1. Material Content

Circular Connectors generally use metalwork parts made of brass, aluminium, phosphor-bronze or steel, which, dependant on the particular application, may be passivated and protected with cadmium or zinc plate – in conjunction with chromated or anodised surface finishes. The insulating materials can either be natural or synthetic rubber, together with plastic or glass-filled plastic moulded parts. Contact materials vary but are usually made of brass, phosphor-bronze, alumel or chromel.

2. Electric Shock, Burns and Fire

Hazard can occur if the product is used outside the specified parameters or if the product is damaged, wrongly wired or poorly assembled, or poorly integrated into larger equipments, or contaminated with conductive fluids. Live circuit terminations must be protected and live circuits never broken by disconnecting products.

Hot spots may be created when resistance is increased due to damage or incorrect integration particularly soldering, or loose terminations. Overheating can cause breakdown of insulation, electric shock, burns or, ultimately, fire. In the event of fire noxious and/or toxic fumes may be released and, in these circumstances, any fire involving the product should be dealt with by personnel properly equipped. Connectors with exposed terminations or contacts should not be used on the current supply side of a circuit with exposed contacts on an unmated product. Before making a circuit live, the product and wiring should be checked to ensure there is no electrically conducting debris present. Circuit resistance checks should also be conducted before making the circuit live. Always ensure that connectors are assembled and wired by properly trained personnel.

3. Use, Transport and Storage of Products

Care must be exercised to avoid damage to any part of the products during transporting, storage or use. Abnormal transit or storage conditions and abuse during installation can give rise to damage. Products should not be used in a damaged condition.

Improper storage (particularly of damaged products) can give rise to additional hazards particularly corrosion. Attention is specifically drawn to the need for proper storage of products containing cadmium and you are advised to see the Guidance Note from the Health and safety Executive on Cadmium – Health and Safety Precautions.

4. Disposal of Products

Product should not be burnt.

SAFETY RULES

1. FOLLOW THE GUIDELINES GIVEN.
 2. ALWAYS PROTECT LIVE CIRCUITS AND NEVER DISCONNECT A LIVE CONNECTOR.
 3. NEVER USE A DAMAGED CONNECTOR.
 4. NEVER BURN DISCARDED CONNECTORS.
-