

Motorsport Connector Accessories

Protective Caps, Nut Plates and Gaskets
designed to use with Autosport/Motorsport connectors
derived from MIL-DTL-38999 and JN1003



Weald
ELECTRONICS

MANUFACTURERS OF HIGH QUALITY CONNECTORS AND CONNECTOR ACCESSORIES

www.wealdelectronics.com

**MOTORSPORT CONNECTOR ACCESSORIES
CONTENTS**

Section 1: LMD7003/7004 series – Protective caps

General information and characteristics 3

Protective cap styles 4

Dimensions and ordering information 5, 6

Section 2: LMA8684 Series – Nut plates

General information and characteristics 7

Dimensions and ordering information 8

Section 2: LMA8688 Series – Gaskets

General information and characteristics 9

Dimensions and ordering information 10

Product Safety Information 11

**LMD7003/7004 SERIES PROTECTIVE CAPS
GENERAL INFORMATION**



- Designed for bayonet coupling circular Autosport / Motorsport connectors, derived from MIL-DTL-38999 and JN1003
 - Ultra-lightweight design (25-35% lighter than current design)
 - Corrosion resistant aluminium body
 - Anti-vibration locking design
 - Shell machined from solid material for reliable strength and performance
 - Available with or without flexible stainless steel ‘micro’ wire rope lanyards
 - 3D models in all major CAD formats available





CHARACTERISTICS

CHARACTERISTICS	
Shell material	Machined aluminium alloy
Shell finish (standard)	Hard black anodising
Gasket material	Silicone elastomer
Rope material	Stainless Steel
Fastener materials	Copper and PTFE
Operating temperature	-65°C to +175°C
Sealing	Mated caps to IP67

PROTECTIVE CAPS FOR OTHER CONNECTORS AVAILABLE, INCLUDING MIL-DTL-38999 AND MIL-DTL-26482 STYLES

**LMD7003/7004 SERIES PROTECTIVE CAPS
STYLES AVAILABLE**

LMD7003 SERIES - PROTECTIVE CAPS FOR PLUG CONNECTORS

PART NUMBER	PROTECTIVE CAP STYLE	
<p>LMD7003-**-00-005 Without Lanyard</p>	<p>SIZE 02 TO 06</p> 	<p>SIZE 08 TO 24</p> 
<p>LMD7003-**-0*-335 With Stainless Steel Lanyard</p>	<p>SIZE 02 TO 06</p> 	<p>SIZE 08 TO 24</p> 

LMD7004 SERIES - PROTECTIVE CAPS FOR RECEPTACLE CONNECTORS

PART NUMBER	PROTECTIVE CAP STYLE	
<p>LMD7004-**-00-005 Without Lanyard</p>	<p>SIZE 02 TO 06</p> 	<p>SIZE 08 TO 24</p> 
<p>LMD7004-**-0*-335 With Stainless Steel Lanyard</p>	<p>SIZE 02 TO 06</p> 	<p>SIZE 08 TO 24</p> 

* - denotes size. For dimensions and more ordering information see pages 5 and 6.

LMD7003/7004 SERIES PROTECTIVE CAPS
DIMENSIONS AND ORDERING INFORMATION
LMD7003 SERIES - PROTECTIVE CAPS FOR PLUG CONNECTORS

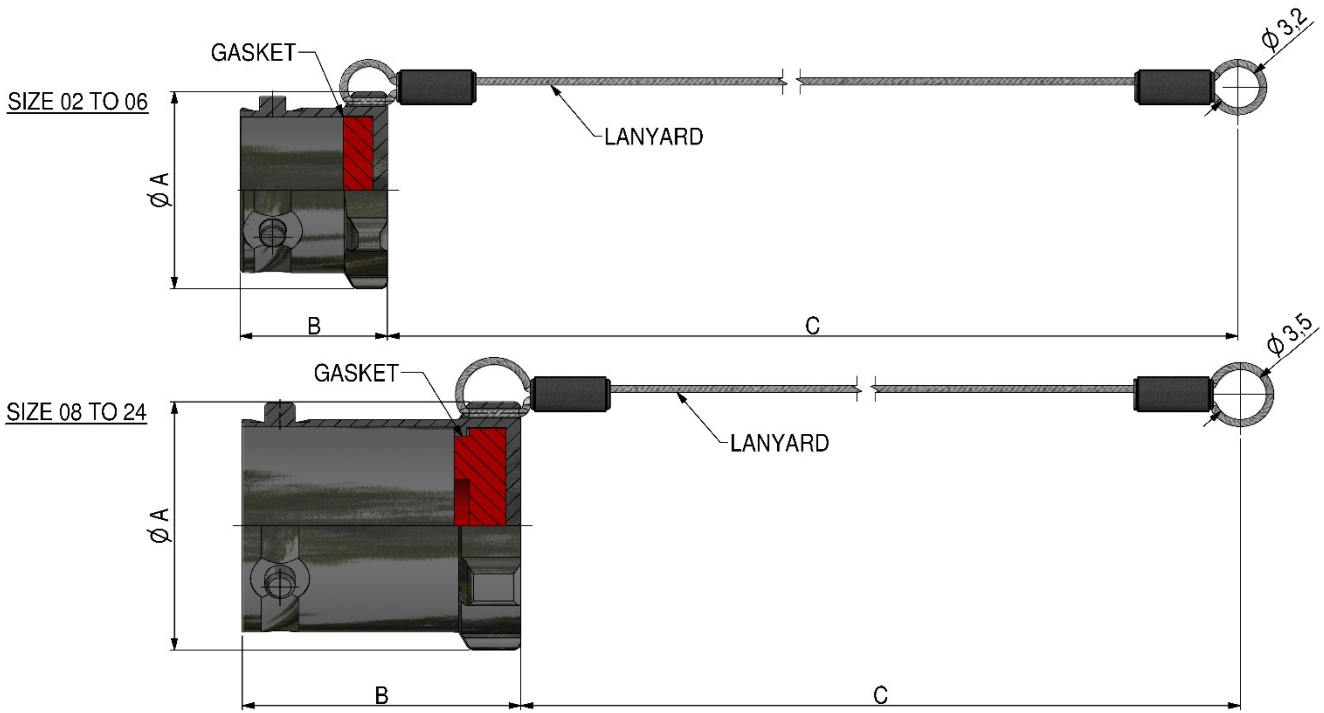

PART NO. EXAMPLE **LMD7003 – 06(A) – 02 – 33 5**

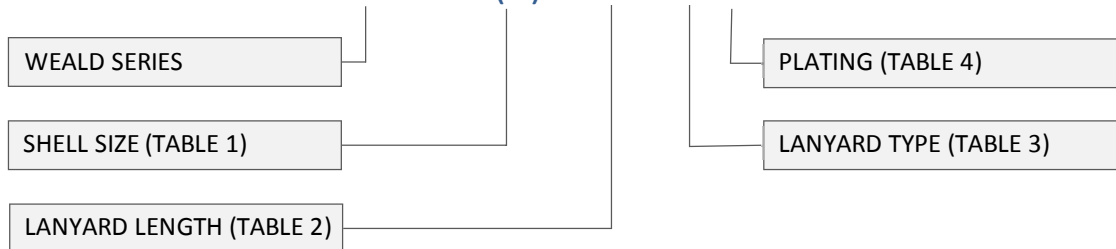

SHELL	$\varnothing A$ [mm]	B [mm]	WEIGHT [g] (WITHOUT LANYARD)
02	10,6	9,0	0.60
04	12,5	9,2	0.85
06A*	13,0	10,0	0.91
06	13,9	10,0	1.21
08	14,5	18,8	2.15
10	17,4	18,8	2.48
12	21,9	18,8	3.85
14	25,0	17,9	4.42
16	28,2	17,9	5.50
18	31,4	17,9	7.59
20	34,6	17,9	8.76
22	37,7	17,9	10.12
24	40,9	17,7	11.39

* - 06A cap mates with size 06-05 connectors.

REF. NO	C - LANYARD LENGTH [mm]	STD FOR SHELL SIZE
00	NO LANYARD	N/A
02	80	02 TO 06
03	125	08, 10
04	140	12 TO 18
05	150	22, 24
OTHER LENGTHS AVAILABLE ON REQUEST		

REF. NO	LANYARD AND ATTACHMENT TYPE
00	NO LANYARD
33	STAINLESS STEEL WIRE ROPE WITH FERRULES OTHER TYPES AVAILABLE ON REQUEST

REF. NO	PLATING
5	HARD BLACK ANODISING OTHER VARIANTS AVAILABLE ON REQUEST

**LMD7003/7004 SERIES PROTECTIVE CAPS
DIMENSIONS AND ORDERING INFORMATION**

LMD7004 SERIES - PROTECTIVE CAPS FOR RECEPTACLE CONNECTORS

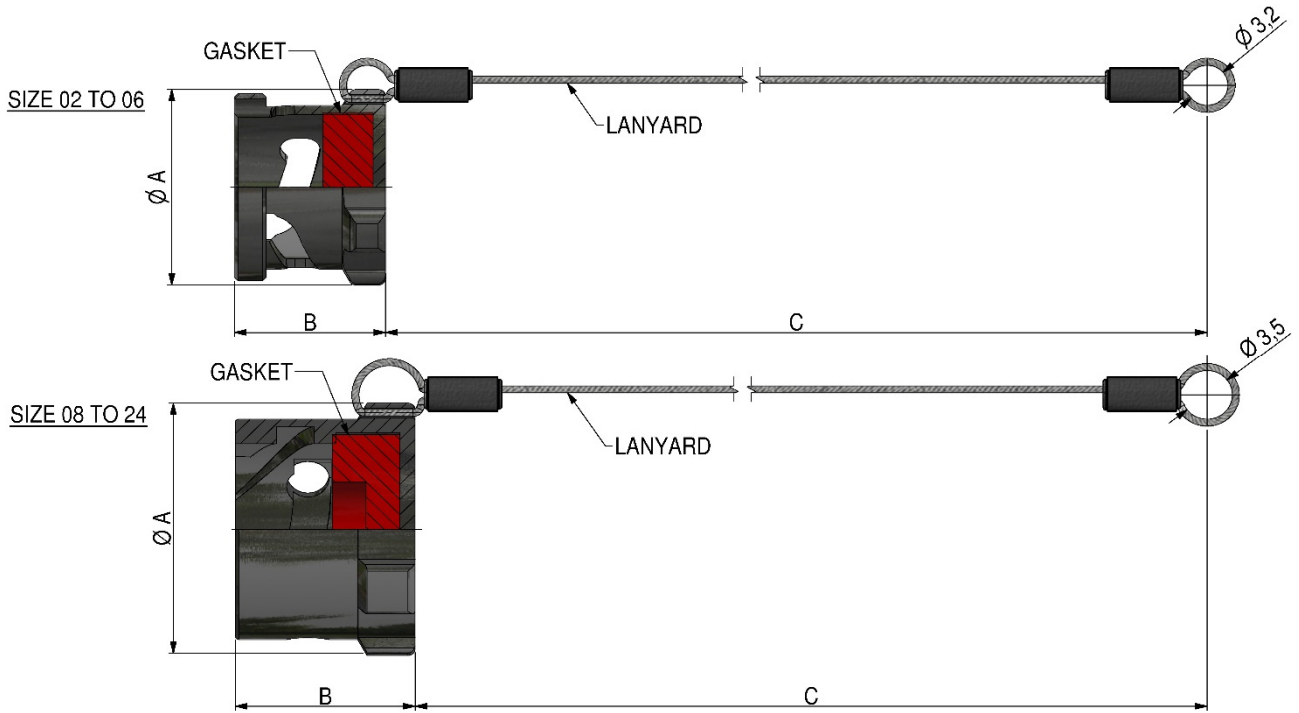

PART NO. EXAMPLE **LMD7004 – 06(A) – 02 – 33 5**

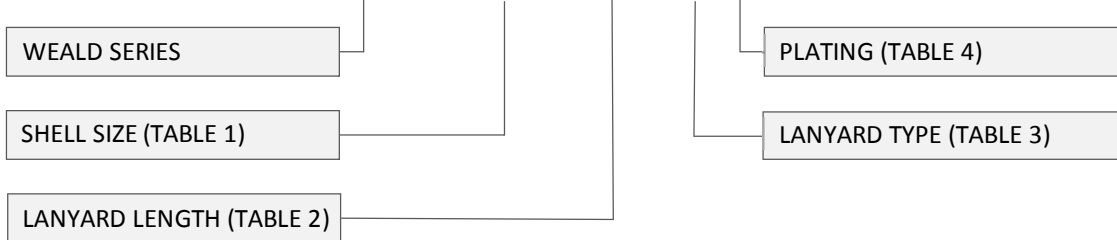

TABLE 1			
SHELL	Ø A [mm]	B [mm]	WEIGHT [g] (WITHOUT LANYARD)
02	11,8	8,7	0.81
04	14,1	10,5	1.37
06A*	14,9	10,2	1.51
06	15,8	10,1	1.67
08	18,1	12,5	2.95
10	21,5	12,5	3.95
12	26,3	12,5	5.69
14	29,5	12,5	6.92
16	32,7	12,5	8.17
18	35,9	12,5	9.58
20	39,1	12,5	11.05
22	42,2	12,5	12.38
24	45,5	13,3	14.37

* - 06A cap mates with size 06-05 connectors

TABLE 2		
REF. NO	C - LANYARD LENGTH [mm]	STD FOR SHELL SIZE
00	NO LANYARD	N/A
02	80	02 TO 06
03	125	08, 10
04	140	12 TO 18
05	150	22, 24
OTHER LENGTHS AVAILABLE ON REQUEST		

TABLE 3	
REF. NO	LANYARD AND ATTACHMENT TYPE
00	NO LANYARD
33	STAINLESS STEEL WIRE ROPE WITH FERRULES
OTHER TYPES AVAILABLE ON REQUEST	

TABLE 4	
REF. NO	PLATING
5	HARD BLACK ANODISING
OTHER VARIANTS AVAILABLE ON REQUEST	

**LMA8684 SERIES NUT PLATES
GENERAL INFORMATION**



- Designed for two-hole oval flange mounted receptacle Autosport / Motorsport connectors derived from MIL-DTL-38999 and JN1003
 - Speed up connector installation in hard-to-reach locations
 - Anti-vibration / self-locking design
 - Lightweight and corrosion resistant
 - Available in 15 sizes
 - 3D models in all major CAD formats available

CHARACTERISTICS

Shell material	Aluminium alloy
Shell finish	Anodised to MIL-A-8625F Type II Cl. 2
Nut material	Stainless Steel 303
Nut finish	Dry-film Lubricant
Operating temperature	-65°C to +175°C

LMA8684 SERIES NUT PLATES
DIMENSIONS AND ORDERING INFORMATION

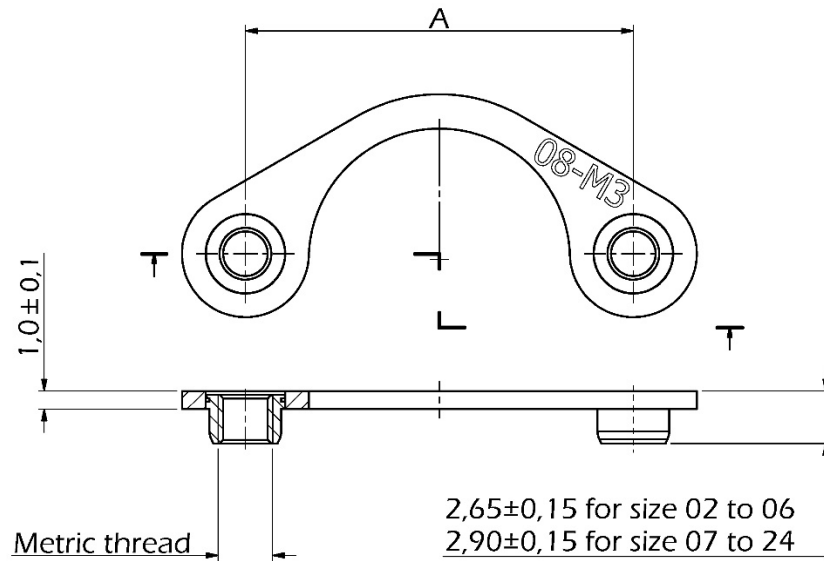

SHELL SIZE	PART NUMBER	THREAD SIZE	A ± 0,15	WEIGHT [g]
02	LMA8684-02-20-00	M2	15.30	0.30
02	LMA8684-02-25-00	M2.5	15.30	0.32
04	LMA8684-04-20-00	M2	16.20	0.33
04	LMA8684-04-25-00	M2.5	16.20	0.35
06	LMA8684-06-25-00	M2.5	18.00	0.38
07	LMA8684-07-00-00	M3	19.80	0.57
08	LMA8684-08-00-00	M3	21.40	0.60
10	LMA8684-10-00-00	M3	25.90	0.63
12	LMA8684-12-00-00	M3	29.10	0.70
14	LMA8684-14-00-00	M3	32.50	0.72
16	LMA8684-16-00-00	M3	34.80	0.74
18	LMA8684-18-00-00	M3	38.20	0.79
20	LMA8684-20-00-00	M3	41.60	0.81
22	LMA8684-22-00-00	M3	45.00	0.91
24	LMA8684-24-00-00	M3	49.50	1.01

Recommended tightening torques*

M2.0 – 20cNm (recommended), 30cNm (max)

M2.5 – 40cNm (recommended), 60cNm (max)

M3.0 – 60cNm (recommended), 90cNm (max)

* - for guidance only, depend on fixings and mounting method.

**LMA8688 SERIES GASKETS
GENERAL INFORMATION**

- Designed for two-hole oval flange mounted receptacle Autosport / Motorsport connectors derived from MIL-DTL-38999 & JN1003
 - Made from fluoroelastomer rubber
 - Resistant to degradation through exposure to most motorsport fluids*
 - Long-term sealing performance
 - Available in 13 sizes
 - 3D models in all major CAD formats available

CHARACTERISTICS	
Material	Fluoroelastomer rubber (Viton)
Continuous operating temperature	-20 to +200°C
Maximum operating temperature	+300°C

* Note: Not recommended for long term immersion in fuels containing MEOH, ETOH, MTBE. etc.

LMA8688 SERIES GASKETS
DIMENSIONS AND ORDERING INFORMATION

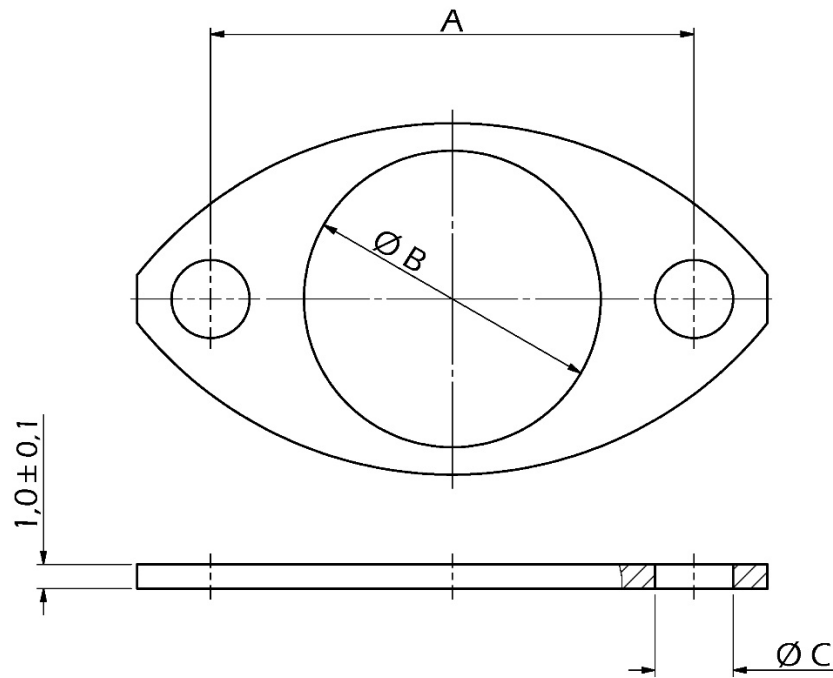

SHELL SIZE	PART NUMBER	A ± 0,25	Ø B ± 0,20	Ø C ± 0,25
02	LMA8688-02-00-00	15.30	8,8	2,70
04	LMA8688-04-00-00	16.20	10,5	2,70
06	LMA8688-06-00-00	18.00	12,05	2,70
07	LMA8688-07-00-00	19.80	12,35	3,20
08	LMA8688-08-00-00	21.40	12,50	3,20
10	LMA8688-10-00-00	25.90	15,50	3,20
12	LMA8688-12-00-00	29.10	19,55	3,20
14	LMA8688-14-00-00	32.50	22,72	3,20
16	LMA8688-16-00-00	34.80	25,90	3,20
18	LMA8688-18-00-00	38.20	29,07	3,20
20	LMA8688-20-00-00	41.60	32,25	3,20
22	LMA8688-22-00-00	45.00	35,40	3,20
24	LMA8688-24-00-00	49.50	38,60	3,80

PRODUCT SAFETY INFORMATION

These notes are intended to be used in conjunction with the Product Catalogue and Product Specification. Products may be safely used in the applications for which they have been designed and within the specified rating and environments. If products are exposed to conditions outside the performance ratings or specified environments they may constitute a hazard. In particular it should be noted that:-

1. Material Content

Circular Connectors generally use metalwork parts made of brass, aluminium, phosphor-bronze or steel, which, dependant on the particular application, may be passivated and protected with cadmium or zinc plate – in conjunction with chromated or anodised surface finishes. The insulating materials can either be natural or synthetic rubber, together with plastic or glass-filled plastic moulded parts. Contact materials vary but are usually made of brass, phosphor-bronze, alumel or chromel.

2. Electric Shock, Burns and Fire

Hazard can occur if the product is used outside the specified parameters or if the product is damaged, wrongly wired, poorly assembled, poorly integrated into larger equipment, or contaminated with conductive fluids. Live circuit terminations must be protected and live circuits never broken by disconnecting products.

Hot spots may be created when resistance is increased due to damage or incorrect integration particularly soldering, or loose terminations. Overheating can cause breakdown of insulation, electric shock, burns or, ultimately, fire. In the event of fire noxious and/or toxic fumes may be released and, in these circumstances, any fire involving the product should be dealt with by personnel properly equipped. Connectors with exposed terminations or contacts should not be used on the current supply side of a circuit with exposed contacts on an unmated product. Before making a circuit live, the product and wiring should be checked to ensure there is no electrically conducting debris present. Circuit resistance checks should also be conducted before making the circuit live. Always ensure that connectors are assembled and wired by properly trained personnel.

3. Use, Transport and Storage of Products

Care must be exercised to avoid damage to any part of the products during transporting, storage or use. Abnormal transit or storage conditions and abuse during installation can give rise to damage. Products should not be used in a damaged condition.

Improper storage (particularly of damaged products) can give rise to additional hazards particularly corrosion. Attention is specifically drawn for the proper storage of products containing cadmium and you are advised to see the Guidance Note from the Health and safety Executive on Cadmium – Health and Safety Precautions.

4. Disposal of Products

Product should not be burnt.

SAFETY RULES

1. FOLLOW THE GUIDELINES GIVEN.
2. ALWAYS PROTECT LIVE CIRCUITS AND NEVER DISCONNECT A LIVE CONNECTOR.
3. NEVER USE A DAMAGED CONNECTOR.
4. NEVER BURN DISCARDED CONNECTORS.