

# PCB connector for SMD

## 974-D-SMD-DS

Screw connection 45°-angle to PCB

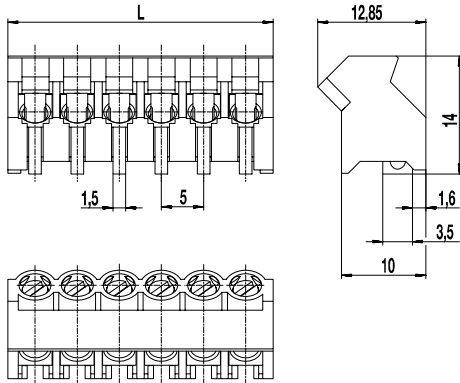
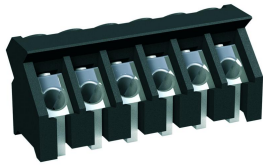

L = pole length x pitch + 1,5 mm

### PCB Layout

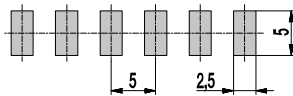

Solder paste thickness: 0,2 - 0,25 mm

By creating the 974-D-SMD-DS, WECO offers a PCB terminal for the reflow soldering process with a pitch of 5 mm in true surface mount technology. The wire entry has a connection angle of 45° to the PCB. This offers the advantage that terminal rows can be located space savingly one behind the other. The housing material consists of high temperature resistant plastic and is specially designed in order to assure a good hot-air circulation during the reflow soldering process in the convection oven. The wire entry side of the terminal has to be placed in flowing direction.

The screws are turned in to the optimal length of engagement by the factory. It is not to be excluded that the position of the screws may change by transport. Therefore it can be necessary that the screw has to be turned back for using the maximum permissible wire cross-section.

### Part Numbers

No. of poles	974-D-SMD-DS	Length	PU
2	20.874.402	11,5	250
3	20.874.403	16,5	250
4	20.874.404	21,5	200
5	20.874.405	26,5	100
6	20.874.406	31,5	100

further number of poles on request

### General Information

Pitch	5 mm
No. of poles	2 - 6

### Technical Data

Clamping Range	<i>solid / flexible / AWG</i> 0,75 - 4 mm <sup>2</sup> / 0,75 - 2,5 mm <sup>2</sup> / 18 - 12 AWG		
Rated Cross Section	2,5 mm <sup>2</sup>		
Wire Stripping Length	6 mm ± 0,5 mm		
Overvoltage Category	III	III	II
Pollution Severity Level	3	2	2
Rated Voltage	250 V	320 V	630 V
Rated Impulse Voltage	4 kV	4 kV	4 kV
Rated Insulation Voltage	250 V acc. to EN 60998-1		
Rated Current	24 A		
Torque	0,4 Nm		

### Material

Moulding	PA HT, black, V-0
Comparative Tracking Index	CTI ≥ 600
Insulating Group	I
Temperature Range	-40°C up to 120°C; Reflow solder temperature (Peak) max. 260°C (15-30 s)
Terminal body	Tin plated brass
Screw	M3; zink plated steel, clear passivated
Wire protector	Tin plated tin bronze

### Approvals

	Current	Voltage	Group	AWG	Nm
	20	300	B	18 - 12	0,4
	10	300	D	18 - 12	0,4
	20	300	B	18 - 12	0,4
	10	300	D	18 - 12	0,4

### Options / Accessories

- Consecutive numbering
- Special marking according to drawing
- Self-adhesive marking strip BST-5,00 [1]

### Part Numbers: Tape-on-Reel

No. of poles	974-D-SMD-DS	Tape Width	Tape Height	PU
2	20.874.402.A00	56 mm	14,7 mm	250
3	20.874.403.A00	56 mm	14,7 mm	250
4	20.874.404.A00	56 mm	14,7 mm	250
5	20.874.405.A00	56 mm	14,7 mm	250
6	20.874.406.A00	56 mm	14,7 mm	250

[1] To be fitted after reflow soldering process