

Pin strip for SMD 110-M-211-SMD

Plug-in direction parallel to PCB

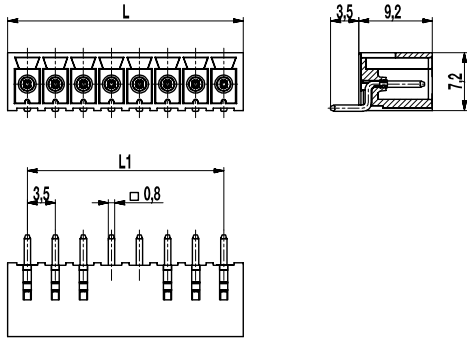

PCB Layout

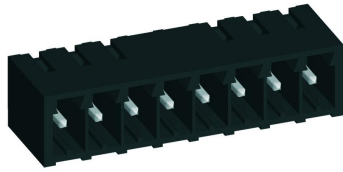
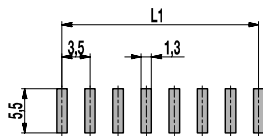

$L1 = (\text{No. of poles} - 1) \times \text{pitch}$
Solder paste thickness: 0,2 mm

The 110-M-211-SMD is a pin strip for the reflow soldering process in a horizontal version with a pitch of 3.5 mm and available in 2 to 12 poles.

It is compatible with all standard connectors series 110 and 110-A-IDC (Insulation Displacement Contacts).

The housing of the pin strips meets the requirements of the elevated soldering temperatures in the lead-free soldering process.

Part Numbers

No. of poles	110-M-211-SMD	Length	PU
2	10.843.102	8,40	1116
3	10.843.103	11,90	792
4	10.843.104	15,40	612
5	10.843.105	18,90	486
6	10.843.106	22,40	414
7	10.843.107	25,90	360
8	10.843.108	29,40	306
9	10.843.109	32,90	270
10	10.843.110	36,40	252
11	10.843.111	39,90	234
12	10.843.112	43,40	216

General Information

Pitch	3,5 mm
No. of poles	2 - 12
Usable with	all plug connectors of series 110
Additional Information	Version with solder flanges see also 110-M-216-SMD

Technical Data

Overvoltage Category	III	III	II
Pollution Severity Level	3	2	2
Rated Voltage	160 V	160 V	320 V
Rated Impulse Voltage	2,5 kV	2,5 kV	2,5 kV
Rated Insulation Voltage	130 V acc. to EN 60998-1		
Rated Current	8 A		
Soldering process	Reflow solder		

Material

Moulding	PA HT, black, V-0
Comparative Tracking Index	CTI ≥ 600
Insulating Group	I
Temperature Range	-40°C up to 120°C; reflow solder temperature (Peak) max. 260°C (15-30 s)
Solder pin	0,8 x 0,8 mm; tin plated brass

Approvals

	Current	Voltage	Group	AWG	Nm
	8	300	B, D		
	8	300	B		

Options / Accessories

- Consecutive numbering
- Special marking according to drawing
- Self-adhesive marking strip BST-3,50 [1]
- Coding elements 120-K-HT-WS

Part Numbers: Tape-on-Reel

No. of poles	110-M-211-SMD	Tape Width	Tape Height	PU
4	10.843.104.A00	56 mm	8 mm	475
5	10.843.105.A00	56 mm	8 mm	475
6	10.843.106.A00	56 mm	8 mm	475
7	10.843.107.A00	56 mm	8 mm	475
8	10.843.108.A00	56 mm	8 mm	475
9	10.843.109.A00	56 mm	8 mm	475
10	10.843.110.A00	56 mm	8 mm	475

further number of poles on request

[1] To be fitted after reflow soldering process