

## PCB connector for THR

### 210-A-111-THR

Screw connection

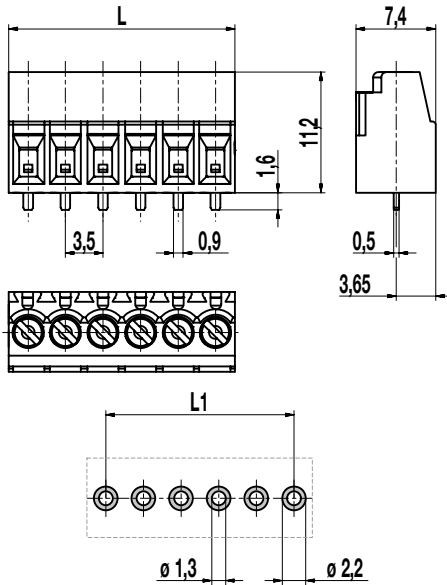

### Part Numbers

No. of poles	210-A-111-THR	Length	PU
2	10.804.102	7,00	250
3	10.804.103	10,50	250
4	10.804.104	14,00	250
5	10.804.105	17,50	200
6	10.804.106	21,00	200
7	10.804.107	24,50	100
8	10.804.108	28,00	100
9	10.804.109	31,50	100
10	10.804.110	35,00	100
11	10.804.111	38,50	100
12	10.804.112	42,00	100

further number of poles on request

### General Information

Pitch	3,5 mm
No. of poles	2 - 12

### Technical Data

Clamping Range	<i>solid / flexible / AWG</i>		
	0,14 - 1,5 mm <sup>2</sup> / 0,14 - 1,5 mm <sup>2</sup> / 30 - 16 AWG		
Rated Cross Section	1 mm <sup>2</sup>		
Wire Stripping Length	5,5 mm ± 0,5 mm		
Overtoltage Category	III	III	II
Pollution Severity Level	3	2	2
Rated Voltage	160 V	160 V	320 V
Rated Impulse Voltage	2,5 kV	2,5 kV	2,5 kV
Rated Insulation Voltage	130 V acc. to EN 60998-1		
Rated Current	12,5 A		
Soldering process	Reflow solder		
Hole in PCB	ø 1,3 mm		
PCB thickness	1,6 mm		
Torque	0,2 Nm		

### Material

Moulding	PA HT, black, V-0
Comparative Tracking Index	CTI ≥ 600
Insulating Group	I
Temperature Range	-40°C up to 120°C; reflow solder temperature (Peak) max. 260°C (15-30 s)
Terminal body	Nickel plated brass
Pressure clamp	Copper alloy, tin plated
Screw	M2; copper alloy, tin plated
Solder pin	Copper alloy, tin plated

### Options / Accessories

- Consecutive numbering
- Special marking accord. drawing
- Self-adhesive marking strip [1]
- Version with anti-twist-peg
- Tape-on-Reel on request
- White colour on request
- Other solder pin lengths on request

[1] To be fitted after reflow soldering process