

PCB connector

950-T(-DS)

Screw connection, interlocking

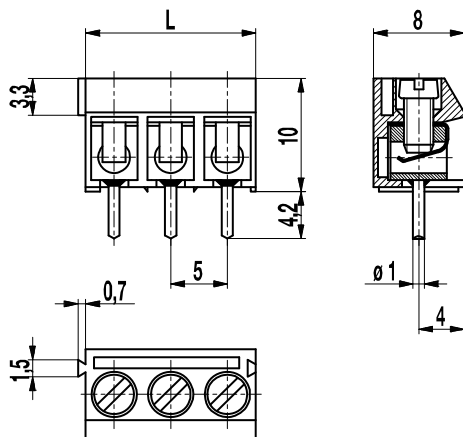

The PCB connector 950-T with a pitch of 5 mm is available in 2- and 3-pole design. Lateral latching elements on the housing allow to latch the PCB connector to longer terminal strips without pole loss.

The wire protector of the "DS"-version reliably prevents damage to multi-wire flexible conductors by the turning screw. The screws are secured against self-loosening.

Part Numbers

No. of poles	950-T	950-T-DS	Length	PU
2	10.871.602	20.871.602	10,00	250
3	10.871.603	20.871.603	15,00	250

General Information

Pitch	5 mm
No. of poles	2 + 3

Technical Data

Clamping Range	<i>solid / flexible / AWG</i>		
	<i>without wire protector</i>		
	<i>with wire protector</i>		
Rated Cross Section	1,5 mm ²		
Wire Stripping Length	6 mm ± 0,5 mm		
Overvoltage Category	III	III	II
Pollution Severity Level	3	2	2
Rated Voltage	160 V	160 V	320 V
Rated Impulse Voltage	2,5 kV	2,5 kV	2,5 kV
Rated Insulation Voltage	130 V acc. to EN 60998-1		
Rated Current	17,5 A		
Hole in PCB	ø 1,3 mm		
Torque	0,4 Nm		

Material

Moulding	PA, grey, V-0
Comparative Tracking Index	CTI ≥ 600
Insulating Group	I
Temperature Range	-40°C up to 100°C
Terminal body	Tin plated brass
Screw	M2,6; zinc plated steel, blue passivated
Solder pin	ø 1 mm; tin plated copper alloy
Wire protector	Tin plated tin bronze

Approvals

	Current	Voltage	Group	AWG	Nm
	15	300	B	26 - 14	0,4
	15	300	B	26 - 14	0,4
	Current	Voltage	mm ²		
	17,5	250	1,5		

Options / Accessories

- Consecutive numbering
- Special marking according to drawing
- Self-adhesive marking strip BST-5,00
- Longer solder pins up to 75 mm