

PCB connector for SMD 930-D-SMD(-DS)

Screw connection, floating terminal bodies

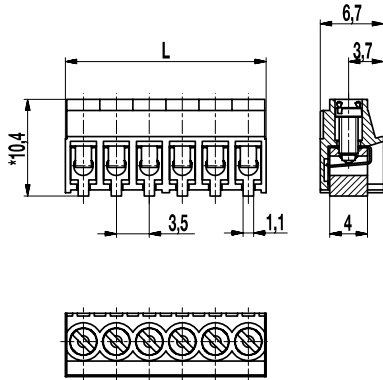
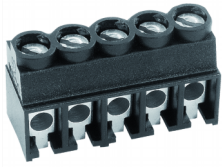

* = Height without -DS: 10,2 mm
L = No. of poles x pitch + 0,3 mm

PCB Layout

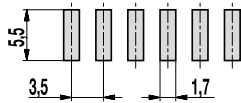

Solder paste thickness: 0,15 - 0,2 mm

The PCB connector 930-D-SMD with a pitch of 3,5 mm for genuine surface mount technology is specifically designed for automated processing assembly and is available in 2 to 12 pole design.

In the Tape-on-Reel packaging, it is equipped with a glued pick disc that can be easily removed after the soldering process.

Its floating terminal bodies compensate irregularities (non planarity and bumps) on the printed circuit board.

The same feature eliminates CTE (coefficient of thermal expansion) mismatch with the PCB and thus promotes excellent in field reliability and the successful passing of thermal cycling testing.

Part Numbers

No. of poles	930-D-SMD	930-D-SMD-DS	Length	PU
2	10.870.602	20.870.602	7,30	250
3	10.870.603	20.870.603	10,80	250
4	10.870.604	20.870.604	14,30	250
5	10.870.605	20.870.605	17,80	200
6	10.870.606	20.870.606	21,30	200
7	10.870.607	20.870.607	24,80	100
8	10.870.608	20.870.608	28,30	100
9	10.870.609	20.870.609	31,80	100
10	10.870.610	20.870.610	35,30	100
11	10.870.611	20.870.611	38,80	100
12	10.870.612	20.870.612	42,30	100

General Information

Pitch	3,5 mm
No. of poles	2 - 12

Technical Data

Clamping Range	<i>solid / flexible / AWG</i>		
<i>without wire protector</i>	0,75 - 1,5 mm ² / 0,75 - 1,5 mm ² / 18 - 16 AWG		
<i>with wire protector</i>	0,25 - 1 mm ² / 0,25 - 1 mm ² / 24 - 18 AWG		
Rated Cross Section	1 mm ²		
Wire Stripping Length	5 mm ± 0,5 mm		
Overvoltage Category	III	III	II
Pollution Severity Level	3	2	2
Rated Voltage	125 V	160 V	320 V
Rated Impulse Voltage	2,5 kV	2,5 kV	2,5 kV
Rated Insulation Voltage	130 V acc. to EN 60998-1		
Rated Current	13,5 A		
Soldering process	Reflow solder		
Torque	0,2 Nm		
Other specifications	Recommended screwdriver: blade 0,4 x 2,0 mm		

Material

Moulding	PA HT, black, V-0
Comparative Tracking Index	CTI ≥ 600
Insulating Group	I
Temperature Range	-40°C up to 120°C; reflow solder temperature (Peak) max. 260°C (15-30 s)
Terminal body	Tin plated brass
Screw	M2; tin plated brass
Wire protector	German silver

Approvals

	Current	Voltage	Group	AWG	Nm
	10	150	B	26 - 16	0,23
	10	150	B	26 - 16	0,2

Options / Accessories

- Special marking according to drawing
- Self-adhesive marking strip BST-3,50 [1]
- White housing colour on request

Part Numbers: Tape-on-Reel

No. of poles	930-D-SMD	930-D-SMD-DS	Tape Width	Tape Height	PU
2	10.870.602.A00	20.870.602.A00	24 mm	11,3 mm	500
3	10.870.603.A00	20.870.603.A00	24 mm	11,3 mm	500
4	10.870.604.A00	20.870.604.A00	24 mm	11,3 mm	500
5	10.870.605.A00	20.870.605.A00	32 mm	11,3 mm	500
6	10.870.606.A00	20.870.606.A00	44 mm	11,3 mm	500
12	10.870.612.A00	20.870.612.A00	56 mm	11,3 mm	500

further number of poles on request

[1] To be fitted after reflow soldering process