



## HOW AND WHY

### Electric Vehicle Contactors Overcome Damaging Electrical Arcs

Willow Technologies Limited ([www.willow.co.uk](http://www.willow.co.uk)), the European distributor for LSIS, presents a detailed look at LSIS' new and exciting range of GER Series Electric Vehicle (EV) Contactors, what they are, why we need them and how they are able to cope with EV motor controller demands in small to medium size vehicles of all types, easily fitting in to confined spaces, capable of interrupting high voltage DC currents repeatedly and interrupting high short circuit currents in an emergency!



#### What and why!

Electric Vehicle (EV) Contactors primarily act as the main contactors in electric vehicle drive circuits in all sizeable electric vehicles: cars, trucks, boats and rail locomotives. The main contactor's function is to open under a potential short circuit load (up to 3000A or more) **making the motor drive electronics as safe as possible**, both in the general running of the vehicle and in a crash situation, **where a potentially damaging, extremely high current short circuit, might occur, resulting in a fire**. They only need do this once! But they **MUST** work...

#### The key features

To summarise the key features of the GER range, they have a high short circuit current rating up to 3200A@450DC, a high short term overload current up to 900A and a continuous current capacity of up to 400A@450VDC. The compact GERs each feature magnetic 'arc blow out' and a special inert gas fill.

#### The process

Typically, an EV motor control system will have a large bank of filter capacitors which can generate a HUGE inrush. In a vehicle, there will be a pre-charge relay or contactor such as the LSIS GER010, GER020 or GER040. This pre-charge relay is wired in series with a current limiting resistor. The pre-charge relay closes first and the current flows into the filter capacitors which, when discharged (empty), will need to charge up to about 80

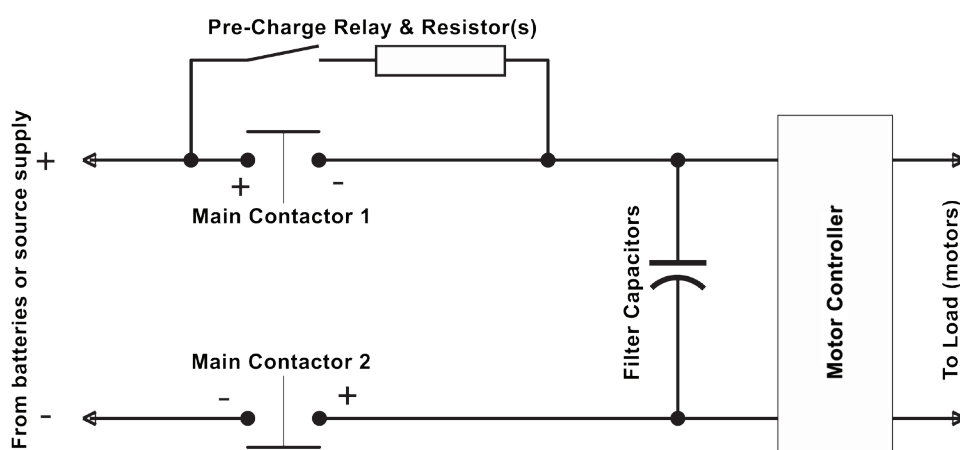

or 90% in order for the system to activate the two main LSIS GER contactors, which close to carry the motor 'run' current (LSIS' GER100, GER150, GER250 and GER400 are all designed to be used as main contactors). When the main contactors close, the pre-charge contactor (having performed its function) opens to disconnect the resistor and

Example Electric Vehicle Engine Circuit Schematic (At least 5 HVDC Contactors would normally be used).

**avoid excess heat and power wastage.** At the point the main contactors close, the vehicle is stationary and the filter capacitors are now charged sufficiently for the vehicle to move. The motor drive electronics take over and the full motor current flows through the main contactors as required by the drive electronics. This whole process occurs extremely quickly so the driver doesn't notice, it's like turning on the ignition of an internal combustion engine car. When the driver pushes the vehicle stop button (turns off the ignition), the Main Contactors open, isolating the batteries from the motor and drive electronics.

### **Repeated short term lower level current overloads**

LSIS GER Series Contactors are constructed to guard against damage to the contactor itself and therefore to the vehicle electronics and source of energy (i.e., the battery). In normal use, the main contactors will experience **repeated short term lower level current overloads**, for example; as the vehicle accelerates. However, in the event of a major incident (e.g. vehicle crashes), the GER main contactors **MUST** open to avoid potentially damaging extremely high short circuit currents with the potential for fire and injury.

**Switching high voltage DC at high currents requires special techniques to cope with the resultant arcs that occur within the GER contactors.** The filter capacitors in the vehicle circuit act as a sponge to draw electrical charge as fast as possible. When they are empty, the inrush spike would be damaging but the resistor limits the charge current to around 10A. As the contacts of the contactor open, a resultant arc begins to form between its two contacts. The temperature of the arc reaches millions of degrees centigrade (akin to a lightning bolt!) and generates a transfer of material from one contact to the other, resulting in a pip and a pit in the newly melted contacts and causing the contactor and consequently the vehicle to fail.

### **How LSIS GER contactors overcome the potentially damaging electrical arc**

Firstly, the contacts are enclosed in a hermetically sealed chamber filled with a special inert gas and are strategically designed with wide air gaps and a bridging contact. The inert gas greatly inhibits arc formation and extends normal switching life.

Secondly, the GER Contactors have a double break contact configuration. One or more magnets fitted inside the chamber are positioned such, that as the main contacts open and an arc begins to form, the magnets simply stretch that arc away from the contacts (blow it out). The arc paths become stretched to an unsustainable level **thus the arc is extinguished – or blown out.**

### **Applications**

The GER100, GER150, GER250 and GER400 can all be used as main contactors and the GER010, GER020 and GER040 can be used for the pre-charge relays. While mainly used in electric vehicles, particularly in the Battery Disconnect Units (BDUs), **these contactors can be used in any application where the need to switch high voltage DC exists**, such as solar panels or test equipment.

[Click here to view datasheet](#)



#### **About Willow Technologies Limited**

Founded in 1989, Willow Technologies is located in Copthorne, West Sussex in the UK. We provide electronic solutions to customers by designing, manufacturing and supplying components and systems globally to the electrical and electronic marketplace. Specialists in switching, sensing, resistive and hermetic seal solutions we have a wide portfolio of sensing technologies and over 60 years of application experience. Our in-house engineering capability and rapid prototyping facility for custom parts enable us to develop products to match specific application requirements. Willow is ISO9001:2008 registered.

#### **For further information please contact:**

[reply@willow.co.uk](mailto:reply@willow.co.uk), Tel +44 (0) 1342 717102



**Willow Technologies Limited**, Unit 3 Borers Yard, Borers Arms Road, Copthorne, West Sussex, RH10 3LH, UK

 [www.willow.co.uk](http://www.willow.co.uk)

 +44 (0) 1342 717102

 +44 (0) 1342 717014

 [reply@willow.co.uk](mailto:reply@willow.co.uk)