

DATE 18 March, 2015No. V-70033C

Messrs. _____

SPECIFICATION

Semiconductor Pressure Sensor - Standard ProductModel: AP4, AG4 Pressure Sensor

Project: _____

Distributor: _____

Reference: _____

_____
Yoshiyuki Uchiumi, Application Engineer
Sensor Department Fujikura Ltd.

Fujikura Ltd.

Table of Contents

1. General	2
2. Principle	2
3. Device Lineup.....	2
4. RoHS.....	2
5. Block Diagram and Pin Connections	3
6. Device Name Code.....	4
7. Absolute Maximum Ratings.....	5
8. General Specifications	5
9. Electrical Characteristics.....	6
10. Communication Interface	7
11. Communication Protocol.....	8
12. Output versus Input Pressure.....	9
13. Transfer Function.....	10
14. Operating Sequence	10
15. Device Marking	11
16. Soldering	12
17. Dimensions and Weights	12
18. Ordering Information	13
19. Tape & Reel Information	13
20. Footprint for PCB (for Reference).....	14
21. Notes.....	15
Appendix: Dimension Drawing	16
9-772-001 APxxN	16
9-772-002 APxxR	17
9-772-003 AGxx3	18
9-772-004 AGxx6	19

Table shown below is revision records of this specification

Rev. C	18 Mar., 2015	Y. Uchiumi	Change arrangement of Slave address code and Custom ID	C
Rev. B	7 Jan., 2015	Y Uchiumi	Added 700kPa(700KG).	B
Rev. A	29 July, 2014	Y Uchiumi	Correction 10. Communication Interface	A
Est.	15 May, 2014	Y Uchiumi		
	Date	Name	Comment	Mark

1. General

This document describes the specifications of Fujikura Pressure Sensors, AP4 and AG4 series.

2. Principle

Fujikura Pressure Sensor is composed of a silicon piezoresistive pressure sensing chip and a signal conditioning integrated circuit. The low-level signal from the sensing chip is amplified, temperature compensated, calibrated, and finally converted to digital data that is proportional to the applied pressure.

3. Device Lineup

This device has the following lineup.

Model	Pressure Type	Supply Voltage	Accuracy	Pressure Range													
				-100	-50	0	25	50	100	200	500	700	1000	kPa			
				(-15)	(-7)		(3)	(7)	(15)	(30)	(70)	(100)	(150)	psi			
AP4 or AG4	Gauge	5.0 Vdc 3.3 Vdc 3.0 Vdc	±1.5 %FS			025KG											
						050KG											
						100KG											
						200KG											
						500KG											
						700KG											
						001MG											
						050KV											
						100KV											
						100KW											

Features

- ✓ Digital output
- ✓ Low power consumption
- ✓ High accuracy
- ✓ Package compatible with XFPM & XFGM integrated pressure sensor
- ✓ Modification available

Applications

- ✓ Battery-operated devices
- ✓ Medical devices
- ✓ Industrial pneumatic devices
- ✓ Consumer devices

4. RoHS

This device is compliant with the Restriction of the use of certain Hazardous Substances in Electrical and Electronic Equipment (RoHS).

5. Block Diagram and Pin Connections

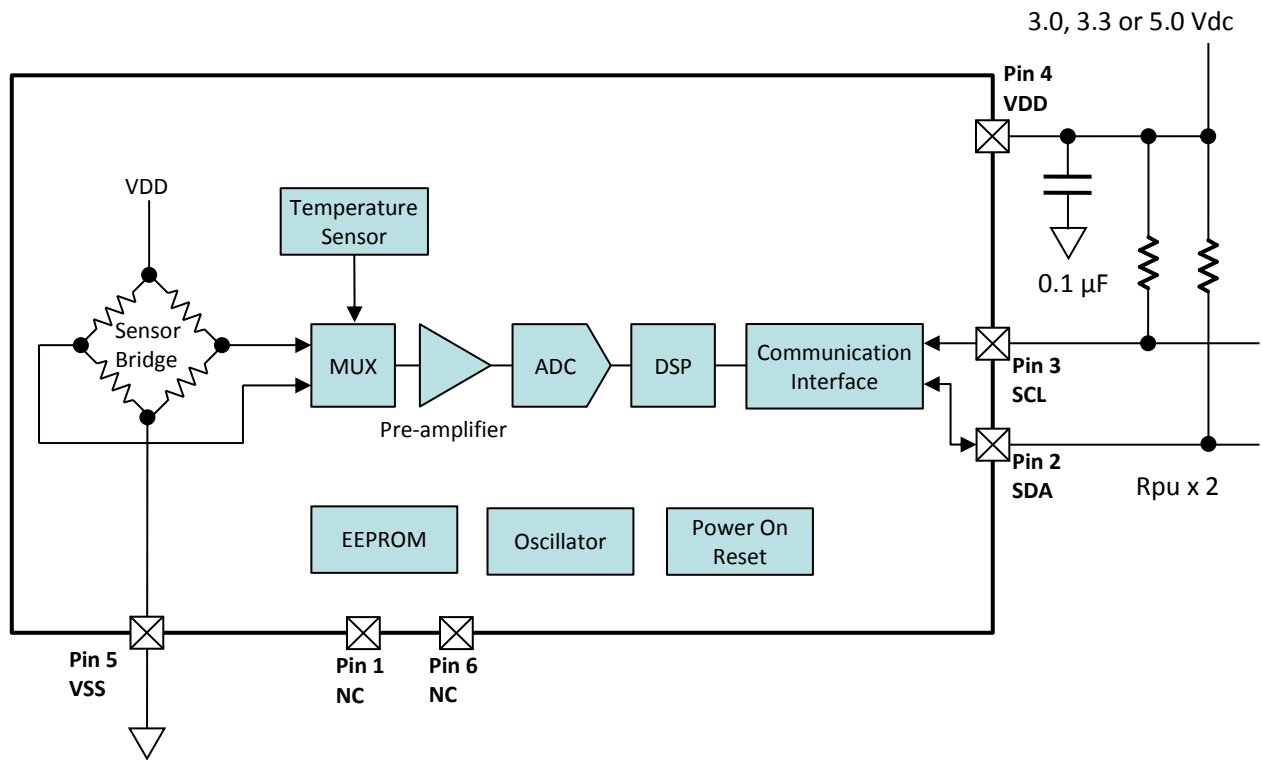

Pin Assignment		Pin No.	Pin Name	I/O	Type	Function	
AP4	AG4						
		1	NC	-	-	-	*2
		2	SDA	I/O	Digital	Serial bidirectional data	
		3	SCL	I	Digital	Serial clock input	
		4	VDD	-	-	Power supply connection	*1
		5	VSS	-	-	Common voltage connection	
		6	NC	-	-	-	-

Notes:

*1) Put a 0.1 μF capacitor between Pin 4 (VDD) and VSS.

*2) Pin 1 and 6 must be open.

6. Device Name Code 

The device name code is consisted of Sensor code, Pressure code, Slave address code and Packing style. For the exact ordering device number, please refer to Chapter 18 Ordering Information.

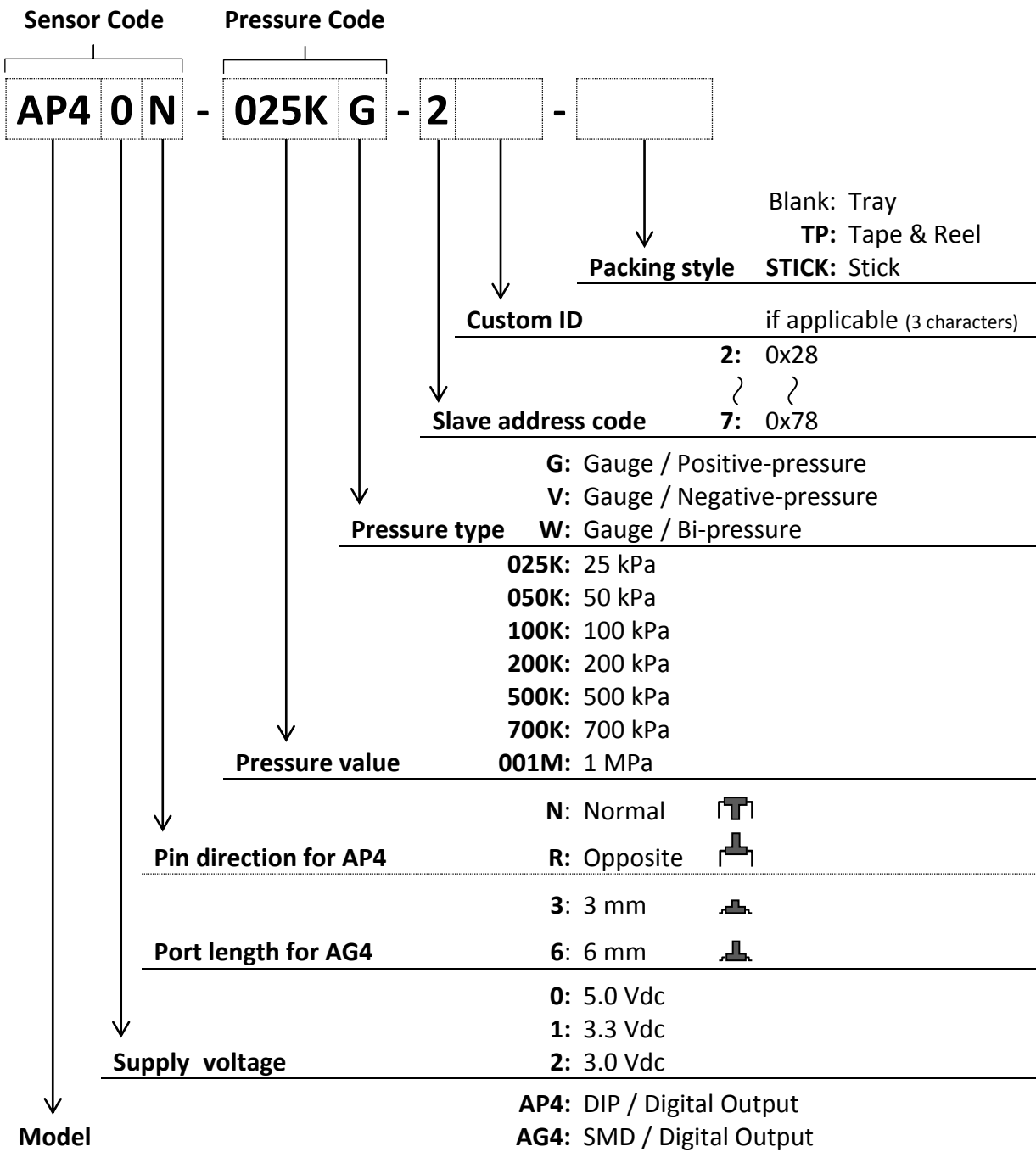

7. Absolute Maximum Ratings

Item		Symbol	Rating			Unit
			Min.	Typ.	Max.	
Load Pressure	Pressure Code	025KG	-	-	+50	kPa
		050KG	-	-	+100	kPa
		100KG	-	-	+200	kPa
		200KG	-	-	+400	kPa
		500KG	-	-	+1	MPa
		700KG	-	-	+1.4	MPa
		001MG	-	-	+1.5	MPa
		050KV	-	-	+100	kPa
		100KV	-	-	+200	kPa
100KW	-	-	+200	kPa		
Supply Voltage		VDDmax	-0.3	-	6	Vdc
Voltage at Digital I/O pins		Vdiomax	-0.3	-	VDD+0.3	Vdc
Operating Temperature		Topt	-40	-	+125	deg. C
Storage Temperature		Tstg	-40	-	+125	deg. C

Note: Absolute maximum ratings are the limits that the device will withstand without damage.

8. General Specifications

Item		Condition	Symbol	Rating			Unit
				Min.	Typ.	Max.	
Supply Voltage	Sensor Code	AP40x, AG40x	VDD	4.75	5	5.25	Vdc
		AP41x, AG41x		3.135	3.3	3.465	
		AP42x, AG42x		2.85	3.0	3.15	
Type of Pressure			-	Gauge pressure			
Pressure Media			-	Non-corrosive gases			
Pressure Range	Pressure Code	025KG	Popt	0	-	+25	kPa
		050KG		0	-	+50	kPa
		100KG		0	-	+100	kPa
		200KG		0	-	+200	kPa
		500KG		0	-	+500	kPa
		700KG		0	-	+700	kPa
		001MG		0	-	+1	MPa
		050KV		-50	-	0	kPa
		100KV		-100	-	0	kPa
100KW	-100	-	+100	kPa			
Compensated Temperature			-	0	-	+85	deg. C
Operating Humidity	Non-condensing		Hopt	30	-	85	%RH
Storage Humidity	Non-condensing		Hstg	30	-	85	%RH
Dielectric Strength				-	-	1	mA
Insulation Resistance				100	-	-	MΩ

Notes:

- *1) Supply voltage (VDD) should be constant.
- *2) Gauge pressure is defined as the difference between applied pressure to the pressure port and atmospheric pressure of the device.
- *3) Ensure the pressure media contains no particulates. The device is not compatible with liquids.
- *4) Pressure range is defined as the measurable pressure range of the device. Do not expose intentionally beyond minimum Popt and maximum Popt.
- *5) Please also refer to Chapter 13 Transfer Function.
- *6) Do not wet the device with dew.
- *7) Dielectric strength is defined as the leakage current between all pins and the package with AC 500 V, 1 minute.
- *8) Insulation resistance is defined as the resistance value between all pins and the package with DC 500 V.

9. Electrical Characteristics

Ambient temperature Ta=25deg. C

Item	Condition	Symbol	Rating			Unit
			Min.	Typ.	Max.	
Offset Pressure Data	Min. Popt, 050KV, 100KV: Max. Popt	Doff	598	819	1040	Count
Full Scale Pressure Data	Max. Popt, 050KV, 100KV: Min. Popt	Dfs	15344	15565	15786	Count
Span Pressure Data	Min. to max. Popt	SD	-	14746	-	Count
Accuracy	0 to 85 deg. C	Error	-1.5	-	+1.5	%FS
Supply Current	VDD = 5 Vdc	Ic	-	-	4.5	mAdc
	VDD = 3.3, 3.0 Vdc		-	-	3.5	
Response Time	for reference	tr	-	1	-	msec.

Notes:

- *1) Offset pressure data (Doff) is defined as the pressure data at minimum Popt. In case of 050KV and 100KV, Offset pressure data (Doff) is defined as the pressure data of maximum Popt.
- *2) Offset error is calibration error of Offset pressure data (Doff) at production. It does not include Long term offset drift. It would be suggested that applications have Auto-zeroing function.
- *3) Full scale pressure data (Dfs) is defined as the pressure data at maximum Popt. In case of 050KV and 100KV, Full scale pressure data (Dfs) is defined as the pressure data of minimum Popt.
- *4) Span pressure data (SD) is defined as the pressure data difference between Offset pressure data (Doff) and Full scale pressure data (Dfs).
- *5) Accuracy consists of the following:
 - Non-linearity
 - Temperature errors over the temperature range 0 to 85 degree C
 - Pressure hysteresis
 - Calibration errors of sensitivity and offset
- *6) The unit of Accuracy “%FS” is defined as a percent error by Span pressure data (SD).
- *7) We can offer lower power mode products as modification line. Please ask to Fujikura.
- *8) Response time (tr) is defined as the time for the change in the pressure data from 10 % to 90 % or from 90 % to 10 % of its final value when the input pressure makes a step change.

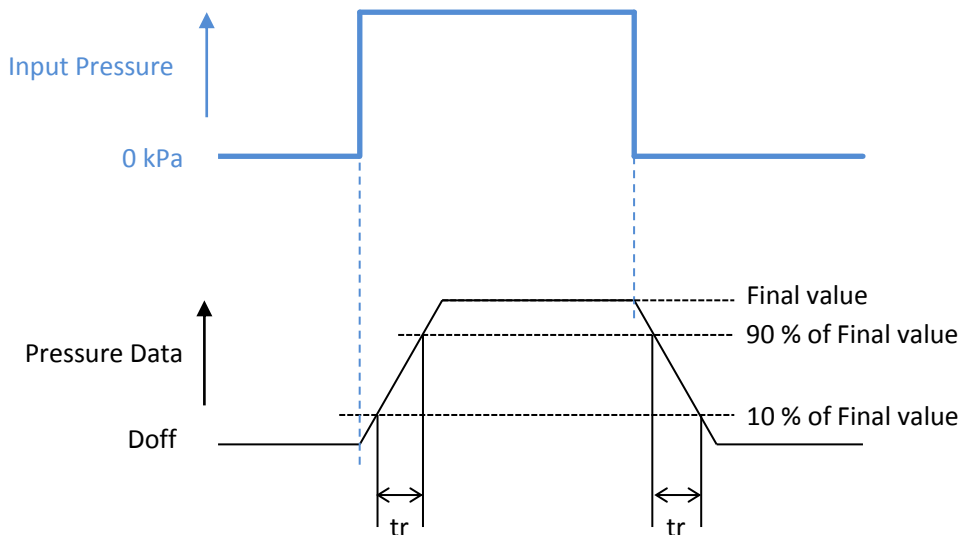

10. Communication Interface 

Ambient temperature Ta=25deg. C

Item	Condition		Symbol	Rating			Unit
				Min.	Typ.	Max.	
Interface				I ² C™			*1, 2
Input Low Voltage	Sensor Code	AP40x, AG40x	VIL	0	-	1	V
		AP41x, AG41x		0	-	0.66	V
		AP42x, AG42x		0	-	0.6	V
Input High Voltage	Sensor Code	AP40x, AG40x	VIH	4	-	5	V
		AP41x, AG41x		2.64	-	3.3	V
		AP42x, AG42x		2.4	-	3	V
Output Low Voltage	Sensor Code	AP40x, AG40x	VOL	-	-	0.5	V
		AP41x, AG41x		-	-	0.33	V
		AP42x, AG42x		-	-	0.3	V
SCL clock frequency			f _{SCL}	100	-	400	kHz
Start condition hold time relative to SCL edge			t _{HDSTA}	0.1	-	-	μsec.
Minimum SCL clock low width			t _{LOW}	0.6	-	-	μsec.
Minimum SCL clock high width			t _{HIGH}	0.6	-	-	μsec.
Start condition setup time relative to SCL edge			t _{SUSTA}	0.1	-	-	μsec.
Data hold time on SDA relative to SCL edge			t _{HDDAT}	0	-	-	μsec.
Data setup time on SDA relative to SCL edge			t _{SUDAT}	0.1	-	-	μsec.
Stop condition setup time on SCL			t _{SUSTO}	0.1	-	-	μsec.
Bus free time between stop condition and start condition			t _{BUS}	2	-	-	μsec.
Load Capacitance	Pin2 SDA, 400kHz		Cmax	-	-	200	pF
Pull-up Resistor	Pin2 SDA, Pin3 SCL		Rpu	1	-	-	kΩ
Slave address	7 bit			0x28 to 0x78			*4

Notes:

*1) I²C™ is a trademark of NXP Semiconductors.*2) There are three differences in this device protocol compared with the original I²C™ protocol:

- Sending a start-stop condition without any transitions on the CLK line (no clock pulses in between) creates a communication error for the next communication, even if the next start condition is correct and the clock pulse is applied. An additional start condition must be sent, which results in restoration of proper communication.
- The restart condition - a falling SDA edge during data transmission when the CLK clock line is still high - creates the same situation. The next communication fails, and an additional start condition must be sent for correct communication.
- A falling SDA edge is not allowed between the start condition and the first rising SCL edge. If using an I²C™ address with the first bit 0, SDA must be held low from the start condition through the first bit.

*3) Combined low and high widths must equal or exceed minimum SCLK period.

*4) Slave address is set by the factory. Please designate the slave address in the device name code. If you can accept any address, 0x28 is recommended.

Timing Diagram

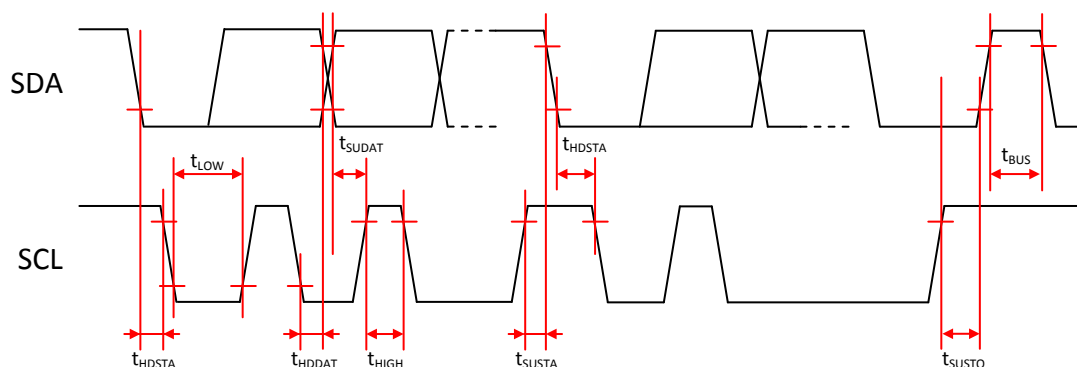

11. Communication Protocol

Item	Measurement Packet	
Data Fetch	<p>The diagram illustrates the bit sequence of a measurement packet. It starts with a Start Condition (S) at bit 6, followed by Slave Address bits [6:0]. A Read (1) command (R) is sent at bit 0. The device responds with an ACK (A) at bit 15, then Status Bit (bits 14-13), Pressure Data [13:8] (bits 12-8), and Pressure Data [7:0] (bits 7-0). The packet ends with an ACK (A) at bit 7, followed by NACK (N) at bit 6 and a Stop Condition (S) at bit 0. Arrows indicate the direction of data flow: Slave Address and Read (1) are sent from Master to Slave; Status Bit and Pressure Data are sent from Slave to Master; ACK and NACK are sent from Master to Slave.</p>	
Status bits	00	Normal operation , good data packet
	01	Device in Command Mode
	10	Stale data: Data has already been fetched since the last measurement cycle.
	11	EEPROM Error

Note:

- *1) Temperature data fetch is available after pressure data. For more information, please ask Fujikura.
- *2) If the status bits are 01, the device must be re-started to turn power supply off and on again.
- *3) If a data fetch is performed before or during the first measurement after power-on reset, then “stale” will be returned, but this data is actually invalid because the first measurement has not been completed.
- *4) If the status bits are 11, do not use the device anymore.

12. Output versus Input Pressure

Pressure Code	Output vs. Input pressure
025KG 050KG 100KG 200KG 500KG 700KG 001MG	<p style="text-align: center;">Temp. = 0 to 85°C</p> <p style="text-align: center;">Input Pressure</p>
050KV 100KV	<p style="text-align: center;">Temp. = 0 to 85°C</p> <p style="text-align: center;">Input Pressure</p>
100KW	<p style="text-align: center;">Temp. = 0 to 85°C</p> <p style="text-align: center;">Input Pressure</p>

13. Transfer Function

$$\text{Pressure Data (Count)} = P \times \alpha + \beta \pm (\text{Pressure Error} \times \text{Temperature Error Multiplier})$$

Parameters

Parameter Pressure Code	P (kPa)	α	β	Pressure Error (Count)
025KG	0 ~ +25	14746/25	819	221
050KG	0 ~ +50	7373/25	819	221
100KG	0 ~ +100	7373/50	819	221
200KG	0 ~ +200	7373/100	819	221
500KG	0 ~ +500	7373/250	819	221
700KG	0 ~ +700	7373/350	819	221
001MG	0 ~ +1000	7373/500	819	221
050KV	-50 ~ 0	-7373/25	819	221
100KV	-100 ~ 0	-7373/50	819	221
100KW	-100 ~ +100	7373/100	8192	221

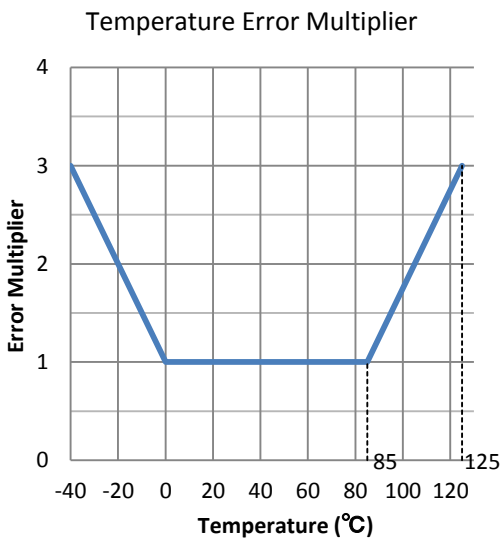

14. Operating Sequence

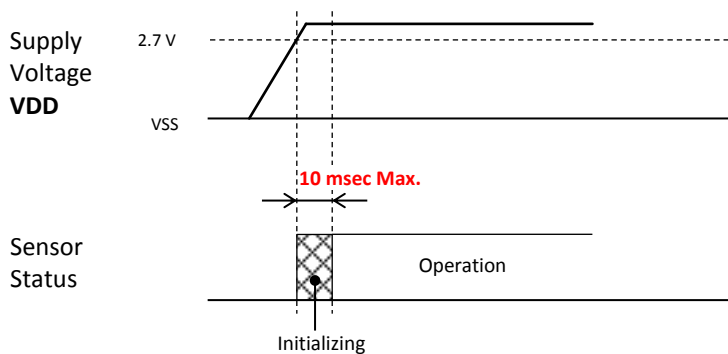

15. Device Marking

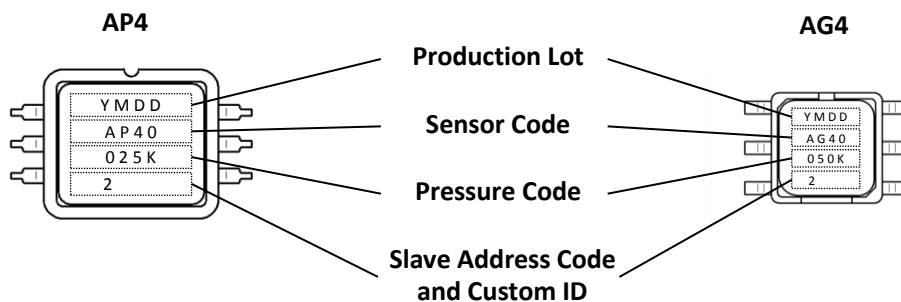

Items		Marking
Production Lot		
Y	Last digit of Production year	0~9
M	Production month	1, 2, 3 ~ 8, 9, X=Oct., Y=Nov., Z=Dec.
DD	Production date	01~31
Sensor Code		
	AP40x	AP40
	AP41x	AP41
	AP42x	AP42
	AG40x	AG40
	AG41x	AG41
	AG42x	AG42
Pressure Code		
	025KG	025K
	050KG	050K
	100KG	100K
	200KG	200K
	500KG	500K
	700KG	700K
	001MG	001M
	050KV	050V
	100KV	100V
	100KW	100W
Slave Address Code		
	2	2
	3	3
	4	4
	5	5
	6	6
	7	7
Custom ID		If applicable

*1

*2

Notes:

- *1) Pin direction for AP4 or Port length for AG4 is not marked on the face plate.
- *2) Custom ID will be added when product is customized for a customer.

16. Soldering

Process	Sensor code	Condition															
Hand Soldering	AP4xx	Soldering iron temperature: 350 deg. C max. Soldering time: 3 seconds max.															
Wave Soldering	AP4xR	Soldering bath temperature: 260 deg. C max. Soldering time: 5 seconds max.															
Reflow Soldering	AG4xx	<p style="text-align: center;">Soldering Profile</p> <table border="1" style="margin-top: 10px;"> <thead> <tr> <th>A</th> <th>B</th> <th>C</th> <th>D</th> <th>E</th> </tr> </thead> <tbody> <tr> <td>Ramp up</td> <td>Pre-heating</td> <td>Ramp up</td> <td>Heating</td> <td>Ramp down</td> </tr> <tr> <td>2 to 4 deg. C / sec.</td> <td>150 to 180 deg. C 60 to 120 sec.</td> <td>2 to 4 deg. C / sec.</td> <td>Above 230 deg. C, 45 sec. max. 245 deg. C max., 10 sec. max.</td> <td>2 to 4 deg. C / sec.</td> </tr> </tbody> </table>	A	B	C	D	E	Ramp up	Pre-heating	Ramp up	Heating	Ramp down	2 to 4 deg. C / sec.	150 to 180 deg. C 60 to 120 sec.	2 to 4 deg. C / sec.	Above 230 deg. C, 45 sec. max. 245 deg. C max., 10 sec. max.	2 to 4 deg. C / sec.
A	B	C	D	E													
Ramp up	Pre-heating	Ramp up	Heating	Ramp down													
2 to 4 deg. C / sec.	150 to 180 deg. C 60 to 120 sec.	2 to 4 deg. C / sec.	Above 230 deg. C, 45 sec. max. 245 deg. C max., 10 sec. max.	2 to 4 deg. C / sec.													

*1, 2
*1, 2
*1, 2
3, 4

Notes:

- *1) NEVER wash the device with any washing liquid. NEVER wash the device with any ultrasonic washing machine.
- *2) Do not put the solder and flux on the device's package.
- *3) Temperature means Surface temperature of the device's package.
- *4) Do not reflow more than twice.

17. Dimensions and Weights

Refer to the following drawing as attached.

Sensor Code	Dimension Drawing	Weight
AP4xN	9-772-001	approx. 1.4 grams
AP4xR	9-772-002	
AG4x3	9-772-003	approx. 0.3 grams
AG4x6	9-772-004	approx. 0.4 grams

18. Ordering Information

Model	Package	Supply Voltage	Pin Direction	Packing	Ordering Device Number	Qty./Packing	
AP4	DIP	5.0 Vdc	Normal	Tray	AP40N- [Pressure Code] -[Slave]	150 Pcs/Tray	
				Stick	AP40N- [Pressure Code] -[Slave] -STICK	40 Pcs/Stick	
			Opposite	Tray	AP40R- [Pressure Code] -[Slave]	150 Pcs/Tray	
				Stick	AP40R- [Pressure Code] -[Slave] -STICK	40 Pcs/Stick	
			3.3 Vdc	Normal	Tray	AP41N- [Pressure Code] -[Slave]	150 Pcs/Tray
					Stick	AP41N- [Pressure Code] -[Slave] -STICK	40 Pcs/Stick
		Opposite	Tray	AP41R- [Pressure Code] -[Slave]	150 Pcs/Tray		
			Stick	AP41R- [Pressure Code] -[Slave] -STICK	40 Pcs/Stick		
		3.0 Vdc	Normal	Tray	AP42N- [Pressure Code] -[Slave]	150 Pcs/Tray	
				Stick	AP42N- [Pressure Code] -[Slave] -STICK	40 Pcs/Stick	
			Opposite	Tray	AP42R- [Pressure Code] -[Slave]	150 Pcs/Tray	
				Stick	AP42R- [Pressure Code] -[Slave] -STICK	40 Pcs/Stick	
			Port Length				
AG4	SMD		5.0 Vdc	3 mm	Tray	AG403- [Pressure Code] -[Slave]	300 Pcs/Tray
		Tape & Reel			AG403- [Pressure Code] -[Slave] -TP	500 Pcs/Reel	
		6 mm		Tray	AG406- [Pressure Code] -[Slave]	300 Pcs/Tray	
				Tape & Reel	AG406- [Pressure Code] -[Slave] -TP	500 Pcs/Reel	
		3.3 Vdc		3 mm	Tray	AG413- [Pressure Code] -[Slave]	300 Pcs/Tray
					Tape & Reel	AG413- [Pressure Code] -[Slave] -TP	500 Pcs/Reel
		6 mm	Tray	AG416- [Pressure Code] -[Slave]	300 Pcs/Tray		
			Tape & Reel	AG416- [Pressure Code] -[Slave] -TP	500 Pcs/Reel		
		3.0 Vdc	3 mm	Tray	AG423- [Pressure Code] -[Slave]	300 Pcs/Tray	
				Tape & Reel	AG423- [Pressure Code] -[Slave] -TP	500 Pcs/Reel	
			6 mm	Tray	AG426- [Pressure Code] -[Slave]	300 Pcs/Tray	
				Tape & Reel	AG426- [Pressure Code] -[Slave] -TP	500 Pcs/Reel	

Pressure Range	Pressure Code
0 ~ +25 kPa	025KG
0 ~ +50 kPa	050KG
0 ~ +100 kPa	100KG
0 ~ +200 kPa	200KG
0 ~ +500 kPa	500KG
0 ~ +700 kPa	700KG
0 ~ +1 MPa	001MG
-50 ~ 0 kPa	050KV
-100 ~ 0 kPa	100KV
-100 ~ +100 kPa	100KW

Slave Address	Slave Address Code
0x28	2
0x38	3
0x48	4
0x58	5
0x68	6
0x78	7

19. Tape & Reel Information

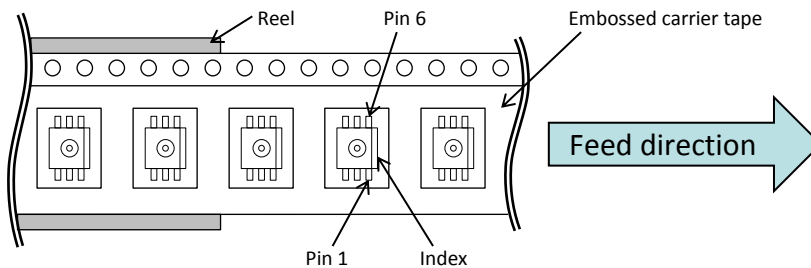

20. Footprint for PCB (for Reference)

Sensor Code	Footprint
AP4xN	<p>Hole for Pressure Port Diameter is depending on your design.</p> <p>6 - ϕ1.8 mm 6 - ϕ0.9 mm Land pads 15.2 mm 2.54 mm 2.54 mm</p>
AP4xR	<p>6 - ϕ1.8 mm 6 - ϕ0.9 mm Land pads 15.2 mm 2.54 mm 2.54 mm</p>
AG4x3	<p>1.7 mm 1.4 mm Land pads 9.4 mm 2.54 mm 2.54 mm</p>
AG4x6	<p>1.7 mm 1.4 mm Land pads 9.4 mm 6.0 mm 2.54 mm 2.54 mm 2 - ϕ1.1 mm (Holes for Projections)</p>

Notes:

- *1) These footprints are for reference. Please evaluate well these footprints, before your mass production.
- *2) When designing your PCB, please also refer to the outline diagrams.

21. Notes

- Fujikura reserves all rights.
- This document is subject to change without notice.
- Limitation, usage, environment, standard warranty and so on are listed on Fujikura web site.
- Please refer to the latest specifications.

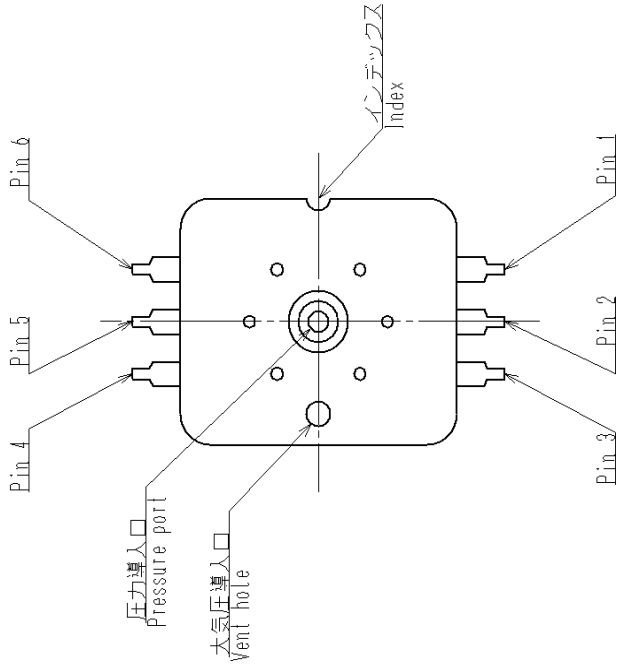
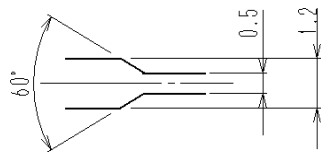
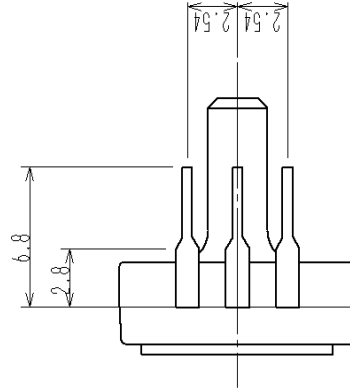
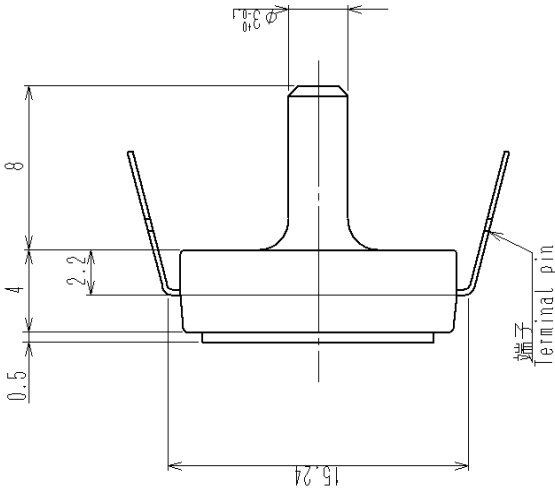
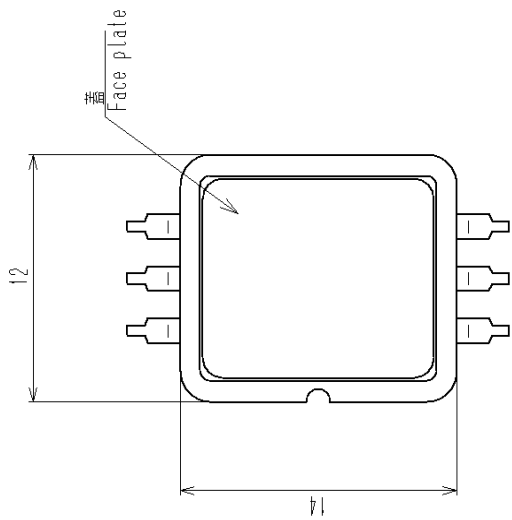

Unless otherwise specified, tolerance: $\pm 0.1\text{mm}$

PART NO.	部品名	材質	個数	概要
PROJECT NAME:		MAT'L	QTY	REMARKS
第3角法 3rd ANGLE PROJECTION	名称TITLE			
單位UNITS m.m	APxxN series			
尺度SCALE Free	Outline diagram			
DATE OF ISSUE	圖面番号DRAWING NO.			REV. MARK
Oct/1/2013	9-772-001			◇

MARK	変更 REVISIONS	年月日 DATE
◇		

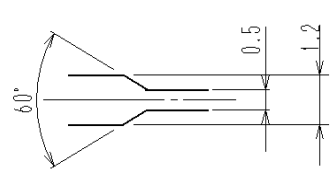
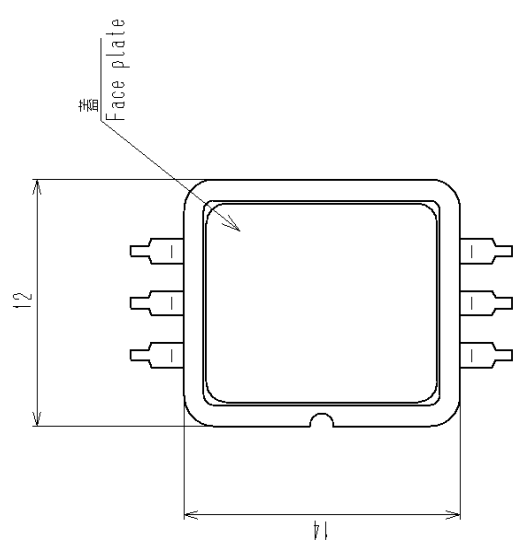
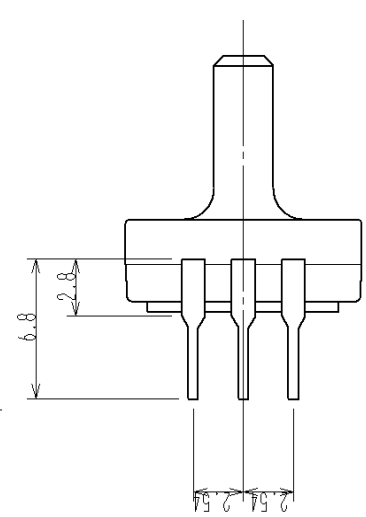
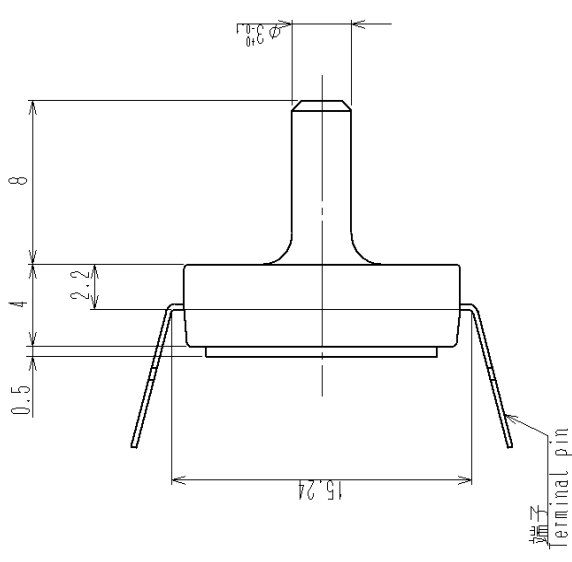
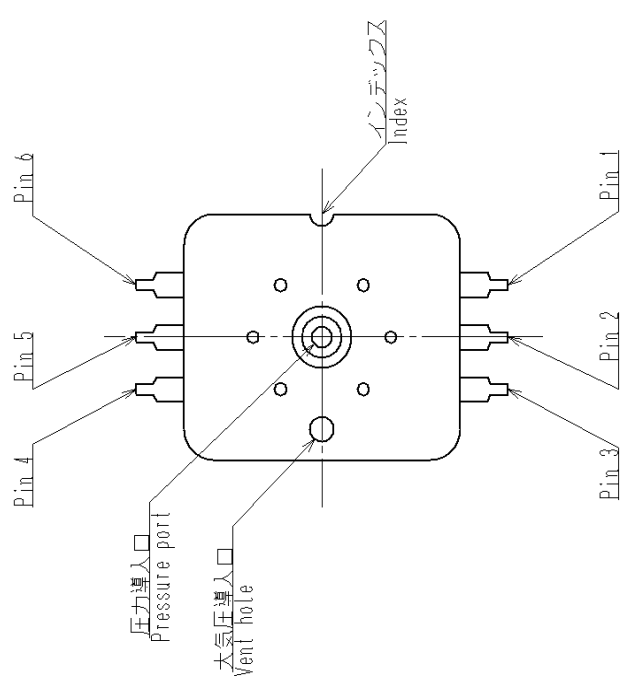

Unless otherwise specified, tolerance: $\pm 0.1\text{mm}$

PART NO.	部品名	材質	個数	換装
PROJECT NAME:		MAT'L	QTY.	REMARKS
名称TITLE				
APxxR series				
Outline diagram				
第3角法 3rd ANGLE PROJECTION				
単位UNITS m.m				
尺度SCALE Free				
DATE OF ISSUE	図面番号DRAWING NO.			REV. MARK
Oct/1/2013	9-772-002			◇

MARK	変更	REVISIONS	年月日 DATE
◇			

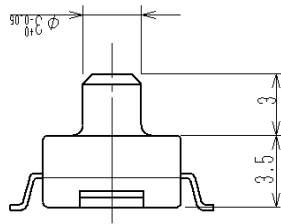
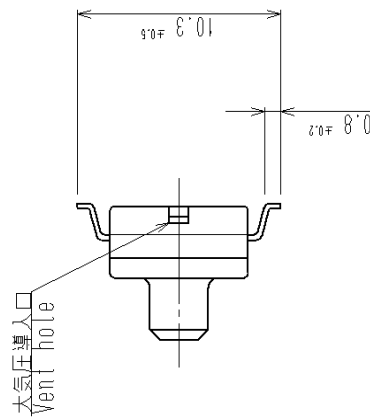
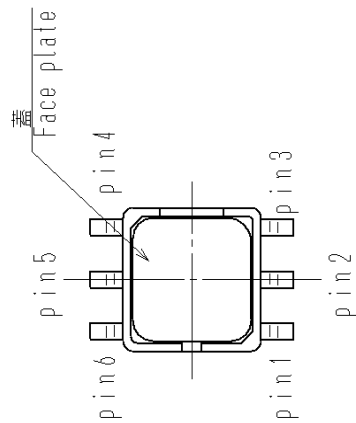
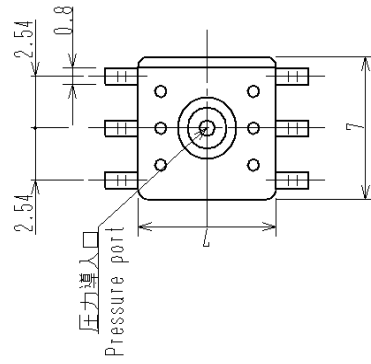

Unless otherwise specified, tolerance: $\pm 0.1\text{mm}$

PART NO.	部品名	材質	個数	摘要
PROJECT NAME:				
名称TITLE				
AGx3 series				
Outline diagram				
第3角法 3rd ANGLE PROJECTION				
单位UNITS m.m				
尺度SCALE Free				
DATE OF ISSUE	図面番号DRAWING NO.			REVISION
0ct/1/2013	9-772-003			◇

◇	MARK	変更 REVISIONS	年月日 DATE
---	------	--------------	----------

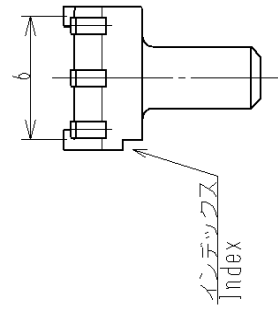
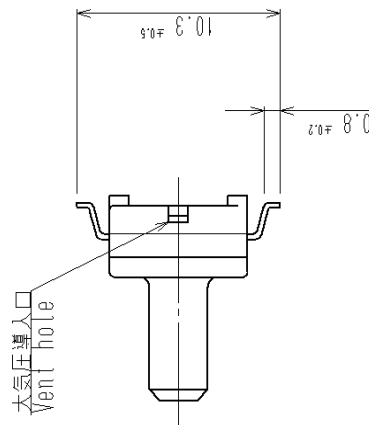
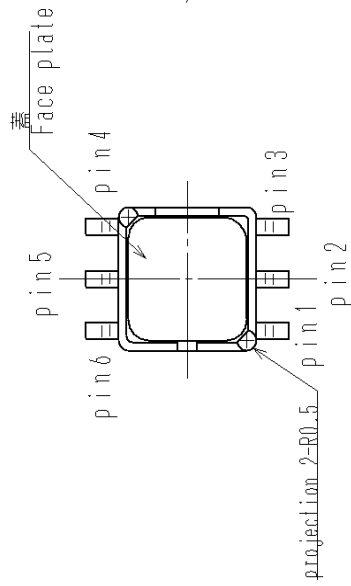
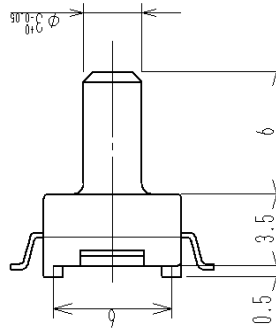
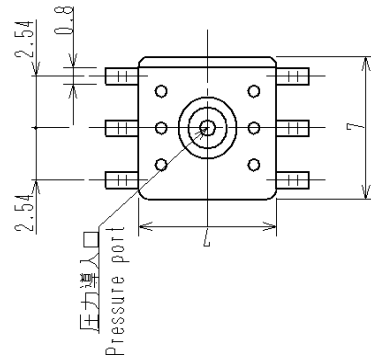

Unless otherwise specified, tolerance: $\pm 0.1\text{mm}$

PART NO.	部品名	材質	個数	摘要
PROJECT NAME:				
名称 TITLE				
AGxx6 series				
Outline diagram				
第3角法 3RD ANGLE PROJECTION				
単位 UNITS m.m				
尺度 SCALE Free				
DATE OF ISSUE	図面番号 DRAWING NO.			REVISION MARK
Oct/1/2013	9-772-004			◇

◇	MARK	変更 REVISIONS	年月日 DATE
---	------	--------------	----------