

# MS2100 2-Axis Magnetic Sensor

## *Specifications and User Instructions*

### **General Description**

The MS2100 is an integrated surface mount technology (SMT) module designed for 2-axis magnetic field sensing. The MS2100 combines PNI Corporation's patented magneto-inductive (MI) sensors and measurement circuit technology into a surface mount package for unparalleled performance. The MI sensors change inductance by 100% over their field measurement range. This variable inductance property is used in the cost and space efficient MS2100, which incorporates a patented temperature, and noise stabilized oscillator/counter circuit with a SPI interface. The microprocessor-compatible SPI interface allows easy access to the MS2100's measurement parameters and resulting field measurement data. The module also includes pins to support the connection of a third MI sensor axis for higher performance applications.

Advantages include 3V operation for compatibility with new systems, low power consumption, small surface mount packaging, large signal noise immunity under all conditions, and a large dynamic range. Resolution and field measurement range are software configurable for a variety of applications. The measurement is very stable over temperature and inherently free from offset drift.

These advantages make PNI Corporation's MS2100 the choice for high volume applications where small size and low power requirements are paramount.

### **Features**

- Low power: draws < 1 mA at 3VDC
- Size: 7 x 7 x 1.35 mm
- Large dynamic range:  $\pm 1100 \mu\text{T}$  ( $\pm 11$  Gauss)
- High resolution field measurement: 0.060  $\mu\text{T}$  at 2048 period
- Operation: 3.0 VDC
- Surface mount package: 20 pads (QFN)
- Fully digital interface: SPI protocol at 3 V
- Optional Carrier Board available for easy prototyping and evaluation
- RoHS Compliant

### **Applications**

- Handheld battery-powered devices with built-in compass feature where space is at a premium
- High-performance magnetic field sensing
- High-performance solid state navigation equipment for automotive, marine, and aeronautic applications
- Direction-finding features for any device with bearing or attitude indicators

### **Ordering Information**

**Table 1: Ordering Information**

Name	Part #	MOQ	Package
MS2100	12913	416	Tray
MS2100	12913P	1	Unsealed Partial Tray
MS2100 on Carrier Board	11900	1	Each
MS2100 Evaluation Kit	90028	1	Each

# SPECIFICATIONS

## CAUTION:

Stresses beyond those listed under **Table 2** may cause permanent damage to the device. These are stress ratings only. Functional operation of the device at these or any other conditions beyond those indicated in the operational sections of the specifications is not implied. Exposure to absolute maximum rating conditions for extended periods may affect device reliability.

**Table 2: Absolute Maximum Ratings**

Symbol	Parameter	Maximum
V <sub>DD</sub>	DC supply voltage	5.25 VDC
V <sub>IN</sub>	Input pin voltage	V <sub>DD</sub> + 0.3 VDC
I <sub>IN</sub>	Input pin current	10 mA at 25 °C
T <sub>STRG</sub>	Storage temperature	-40 to 125 °C

**Table 3: MS2100 General Characteristics at 2048**

Parameter	Minimum	Maximum	Typical
Current (3 VDC) <sup>a</sup>		1.0 mA RMS	0.7 mA RMS
Peak Current		5.0 mA peak	3.5 mA peak
Field measurement range <sup>b</sup> (3 VDC)			± 1100 μT
Gain <sup>c</sup> (3 VDC)	14 counts/μT	28 counts/μT	19 count/μT
Linearity (Error from best fit straight line at ±200 μT)		3%	0.5%
Resolution (in μT)			0.055
Sensor Frequency (3 VDC) Within free Earth's magnetic field			approx. 300 kHz
Operating Temperature	-20°C	70°C	
Storage Temperature	-40°	125 °C	

- a. At period select 2048 and 8Hz sample rate
- b. Field measurement range is defined as the monotonic region of the output characteristic curve.
- c. Gain is defined as the change in the number of counts from the MS2100, when the period select is set to 2048, per change in the magnetic field in uT. For situations requiring less gain and more field measurement range, the gain and resolution can be decreased by a factor of 2 by setting the MS2100 period select to 1024. In practical magnetometer applications, a sensor gain calibration is normally performed when the sensor module is in the host system.

**Table 4: MS2100 Continuous Sampling (3 V) at 8 Hz**

Period Select	Ratio	Typical Gain (Counts/ $\mu$ T)	Resolution* ( $\mu$ T)	Typical Operating Current (mA RMS)
0	/32	0.30	3.33	0.01
1	/64	0.59	1.69	0.02
2	/128	1.2	0.83	0.05
3	/256	2.4	0.42	0.09
4	/512	4.8	0.21	0.17
5	/1024	9.5	0.11	0.35
6	/2048	19	0.05	0.70
7	/4096	38	0.03	1.50

\*Resolution is calculated as 1/Gain. Noise may limit usable resolution at period select values of 6 and 7.

*Typical Operating Characteristics: MS2100 (3 VDC)*

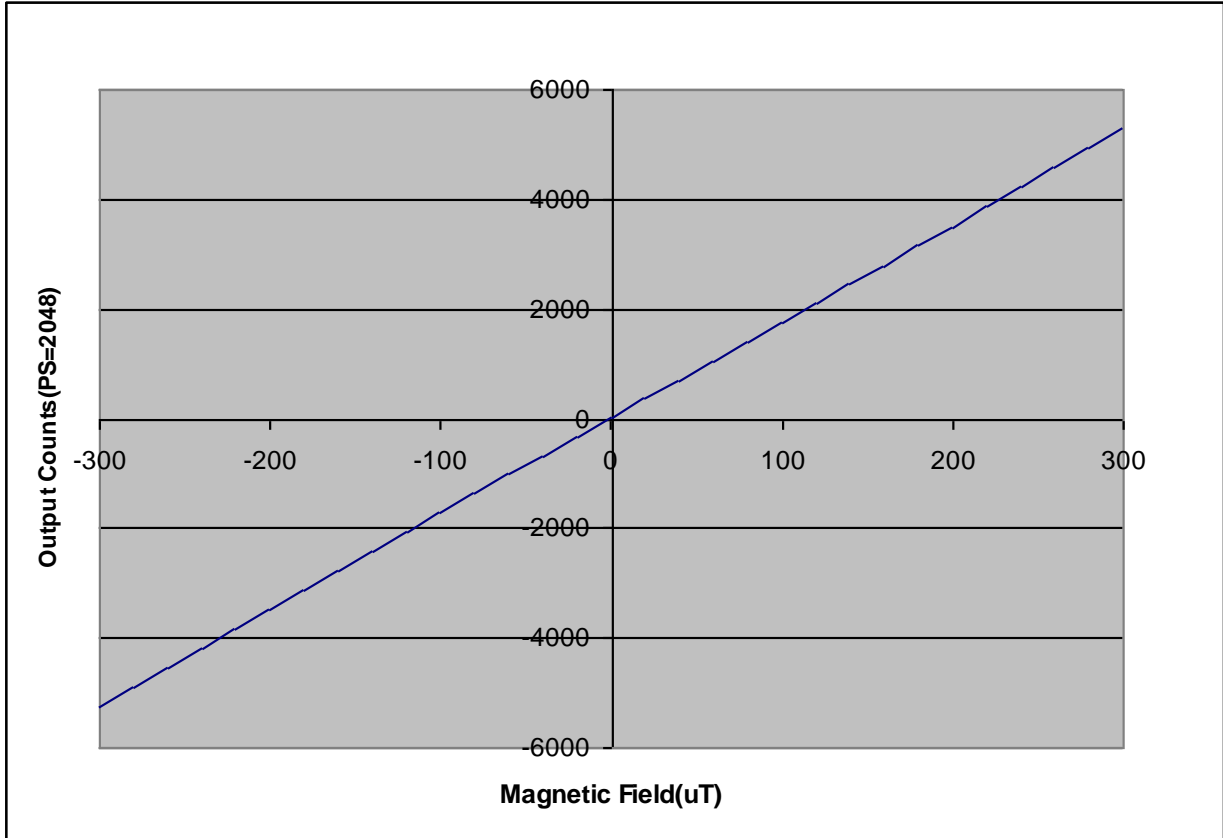

*Figure 1: Typical Sensor Characteristic ( $\pm 300 \mu T$ , PS=2048)*

## Host Processor Interface

All accesses to and from the MS2100 are through a hardware handshaking, synchronous serial interface that adheres to the Motorola SPI protocol. The interface consists of six signals; SCLK, MOSI, MISO, SSNOT, RESET, and DRDY.

**Table 5: MS2100 Pad Descriptions**

Pad	MS2100 Name	Function
1	N.C.	Not connected
2	RESET	Reset input
3	REXT	External timing resistor for higher speed clock
4	DRDY	Data ready
5	DHST	High speed oscillator output. Output is 1/2 clock speed. Used for diagnostics.
6	REXT_GND	Connect the pin to ground.
7	APZDRV	Optional Z sensor drive output (+)
8	APZIN	Optional Z sensor input (+)
9	ANZIN	Optional Z sensor input (-)
10	ANZDRV	Optional Z sensor drive output (-)
11	SSNOT	Active low chip select for SPI port
12	MOSI	Master Out, Slave In for the module SPI port
13	N.C	Not connected
14	MISO	Master In, Slave Out for the module SPI port
15	SCLK	Serial clock input for SPI port. 1 MHz maximum.
16	VDD	Supply Voltage (digital)
17	VDD	Supply Voltage (analog)
18	VSTBY	Input protection clamp diode common
19	VSS	Ground (analog)
20	VSS	Ground (digital)

## ***SPI Port Line Descriptions***

### **MOSI – Master Out Slave In**

The data sent to the MS2100. Data is transferred most significant bit first. The MOSI line will accept data once the SPI is enabled by taking SSNOT low. Valid data must be presented at least 100 nS before the rising edge of the clock, and remain valid for 100 nS after the edge. New data may be presented to the MOSI pin on the falling edge of SCLK.

### **SSNOT – Slave Select Line**

Selects the MS2100 as the operating slave device. The SSNOT line must be low prior to data transfer and must stay low during the entire transfer. Once the command byte is received by the MS2100, and the MS2100 begins to execute the command, the SSNOT line can be deselected until the next SPI transfer.

### **SCLK – Serial Clock**

Used to synchronize both the data in and out through the MISO and MOSI lines. SCLK is generated by a master device. SCLK should be 1 MHz or less. The MS2100 is configured to run as a slave device, making it an input. One byte of data is exchanged over eight clock cycles. Data is captured by the master device on the rising edge of SCLK. Data is shifted out and presented to the MS2100 on the MOSI pin on the falling edge of SCLK.

### **MISO – Master In Slave Out**

The data sent from the MS2100 to the master. Data is transferred most significant bit first. The MISO line is placed in a high impedance state if the slave is not selected (SSNOT = 1).

## Hardware Handshaking Line Descriptions

### RESET

RESET is usually low. RESET must be toggled from low-high-low.

### DRDY - Data Ready

DRDY is low after a RESET; after a command has been received and the data is ready, DRDY will be high. It is recommended that the DRDY line always be used to ensure that the data is clocked out of the MS2100 only when it is available. If it is determined that the DRDY line cannot be used due to lack of I/O lines to the host processor, then the times listed in **Table 6** can be used to set open-loop wait times. The values listed are the maximum delays from the end of the SCLK command until the rise of the DRDY at each period select setting. The maximum delay occurs when the sensor being sampled is in a zero field.

**Table 6: Typical Delay for DRDY**

Period Select	Typical Delay (msec) <sup>a</sup>
/32	0.32
/64	0.53
/128	0.96
/256	1.8
/512	3.5
/1024	6.9
/2048	13.8
/4096	27.4

a. Calculated from  $(1/\text{sensor frequency} \times (\text{period select}) \times 2)$  [Forward & reverse measurement]

## OPERATION

Basic operation will follow these steps. Refer to **Figure 2** and **Figure 3**.

1. SSNOT is brought low.
2. Pulse RESET high (return to low state). You must RESET the MS2100 before every measurement.
3. Data is clocked in on the MOSI line. Once eight bits are read in, the MS2100 will execute the command.
4. The MS2100 will make the measurement. A measurement consists of forward biasing the sensor and making period count; then reverse biasing the sensor and counting again; and finally, taking the difference between the two bias directions.
5. At the end of the measurement, the DRDY line is set to high indicating that the data is ready. In response to the next 16 SCLK pulses, data is shifted out on the MISO line.

If you need to make another measurement, go to Step 2. You can send another command after the reset. In this case, keep SSNOT low. If you will not be using the MS2100, set SSNOT to high to disable the SPI port.

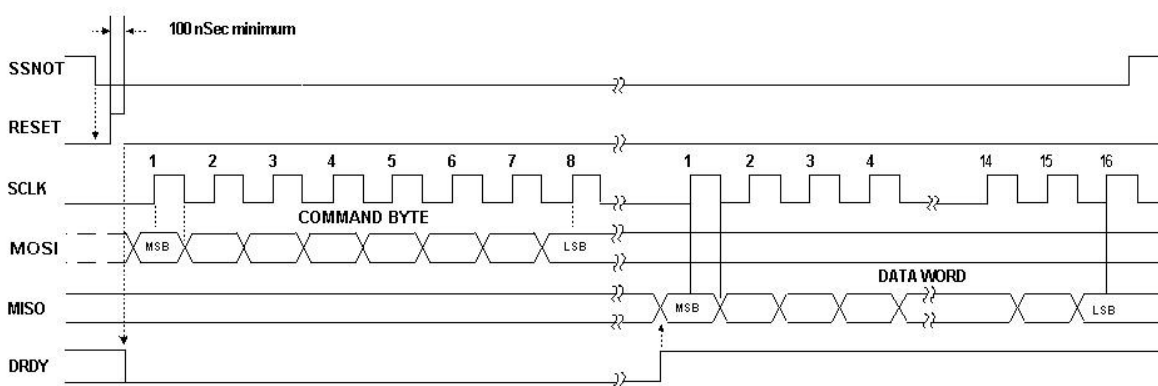

Figure 2: SPI Port Full Timing Sequence ( $cpol=0$ )

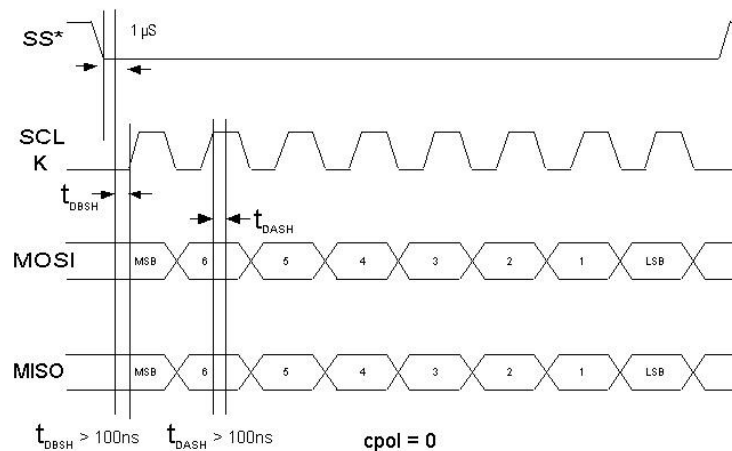

Figure 3: SPI Port Timing Parameters ( $cpol = 0$ )



## *SPI Port Usage Tips*

A SPI port can be implemented using different clock polarity options. The clock polarity used with the MS2100 must be normally low, ( $cpol = 0$ ). **Figure 3** graphically shows the timing sequence ( $cpol = 0$ ). Data is always considered valid while the SCLK is high ( $t_{DASH} = \text{Time, Data After SCLK High}$ ). When SCLK is low, the data is in transition ( $t_{DBSH} = \text{Time, Data Before SCLK High}$ ).

When implementing a SPI port, whether it is a dedicated hardware peripheral port, or a software implemented port using general purpose I/O (also known as *Bit-Banging*) the timing parameters given in **Figure 3** must be met to ensure reliable communications. The clock set-up and hold times,  $t_{DBSH}$  and  $t_{DASH}$  must be greater than 100 nS.

## *Idle Mode*

The MS2100 does not initialize in the idle mode at power-up. The MS2100 must be in a data-ready state for the idle mode to occur. After power-up the MS2100 can be brought to the data-ready state by following these steps for sending a read command to the MS2100.

1. Set SSNOT low.
2. Pulse the RESET line.
3. Send a command to the MS2100 to measure one of the sensors.
4. Once the SSNOT pin is set to high again the MS2100 will go into the low power idle mode.
5. The DRDY pin will eventually go high signifying that the MS2100 is in the data-ready state. The resultant data does not have to be read from the MS2100.

## *Magnetic Measurements*

The MS2100 magnetic sensor operates as an oscillator circuit composed of the internal sensors, bias resistors, digital gates and a comparator. Only one sensor can be measured at a time. The user sends a command byte to the MS2100 through the SPI port specifying the sensor axis to be measured. After dividing by the ratio set by PS2-PS0, the MS2100 will return the result of a complete forward - reverse measurement of the sensor in a 16-bit 2's complement format (Range: -32768 to 32767)

## Command Byte

The operation of the MS2100 is controlled by the data received into the SPI port. The command byte syntax is as follows:

**Table 7: Command Byte Syntax**

Position	7	6	5	4	3	2	1	0
Bit	DHST	PS2	PS1	PS0	ODIR	MOT	ASI	ASO
RESET	0	0	0	0	0	0	0	0

### DHST – High Speed Oscillator Test

When high, the internal high speed clock is set to drive the DHST pad at ½ the clock speed. When low, the DHST pad is set to DVDD. *This is used for debug purposes only, and will not be set in normal operation.*

### PS0, PS1, and PS2 – Period Select

Selects the division ratio applied to the L/R oscillator output to set the period being measured.

**Table 8: Period Select Division Ration**

PS2	PS1	PS0	Ratio
0	0	0	/32
0	0	1	/64
0	1	0	/128
0	1	1	/256
1	0	0	/512
1	0	1	/1024
1	1	0	/2048
1	1	1	/4096

### ODIR – Oscillator Direction

Determines the magnetic oscillator direction if MOT is set to 1. It has no effect on direction when the MOT bit is set to zero. *This is used for debug purposes only, and will not be set in normal operation.*

### MOT – Magnetic Oscillator Test

When set, causes the magnetic oscillator selected by AS0 and AS1 in the directions selected by ODIR to run continuously until MS2100 is reset.

## AS0 and AS1 – Axis Select

Determines which axis is being measured.

**Table 9: Axis Select**

Function	AS1	AS0
X axis	0	1
Y axis	1	0
Z axis*	1	1

\*Available when Sen-Z sensor is externally added.

### Reference Block Diagram MS2100 & Carrier Board

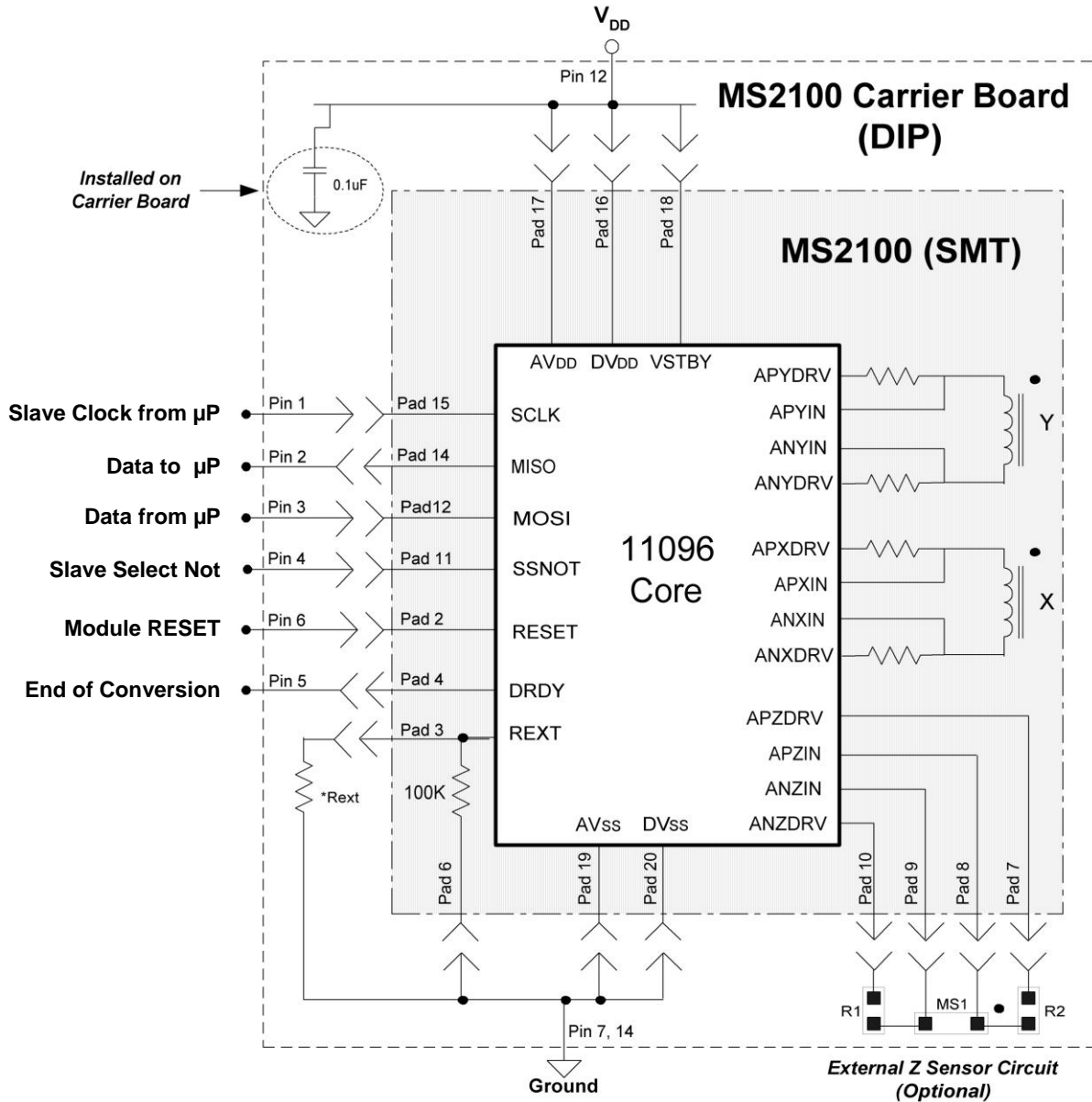

Figure 4: Reference Block Diagram for the MS2100

Pad1 & Pad13: Not Connected.

\*Rext: A 39kΩ resistor can be added in parallel to the internal 100 kΩ resistor for a faster clock speed, however the stability over temperature will be degraded.

# MS2100 Package Information

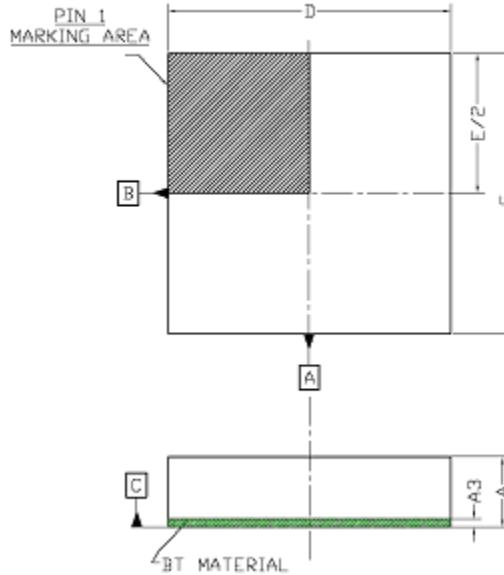

Figure 5: Top and Side Views

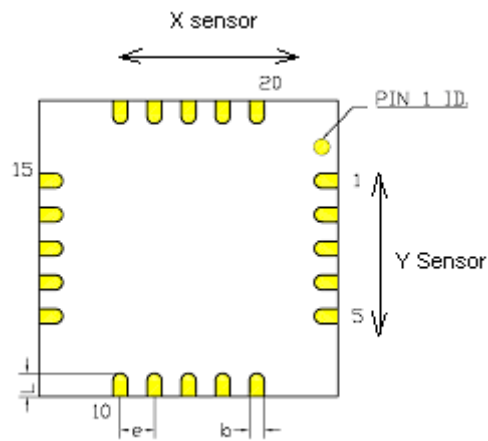
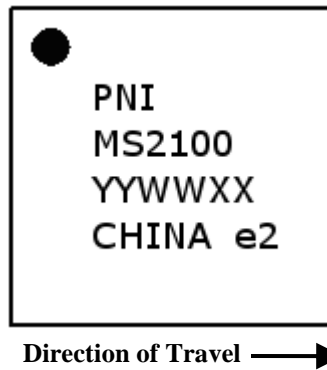

Figure 6: Bottom View

**Table 10: MS2100 Dimensions**

Symbol	Minimum	Nominal	Maximum	Units
A	1.29	1.34	1.39	mm
A3	0.10	0.13	0.16	mm
b	0.28	0.33	0.38	mm
D	6.90	7.00	7.10	mm
E	6.90	7.00	7.10	mm
e	0.75	0.80	0.85	mm
l	0.50	0.60	0.70	mm



*Figure 7: Top View – Markings*

### ***Packaging***

Sealed tray of 416 pieces.

## MS2100 PCB Layout

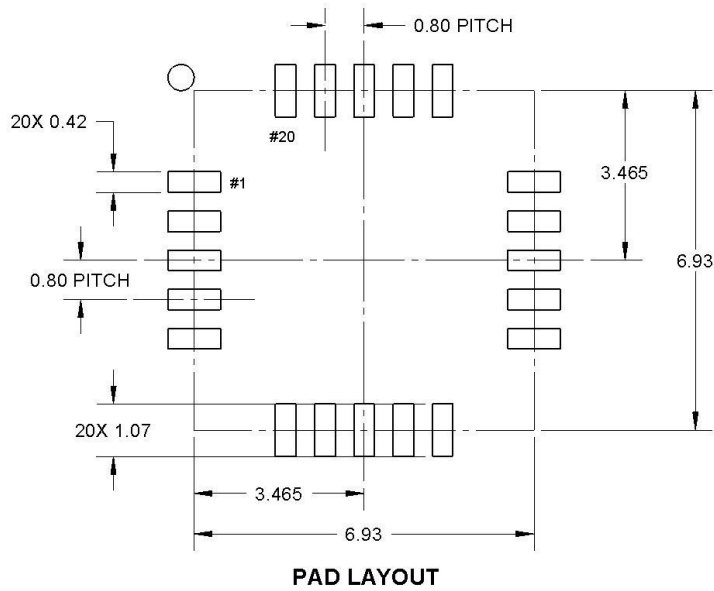

Figure 8: PCB Layout

## MS2100 Carrier Board

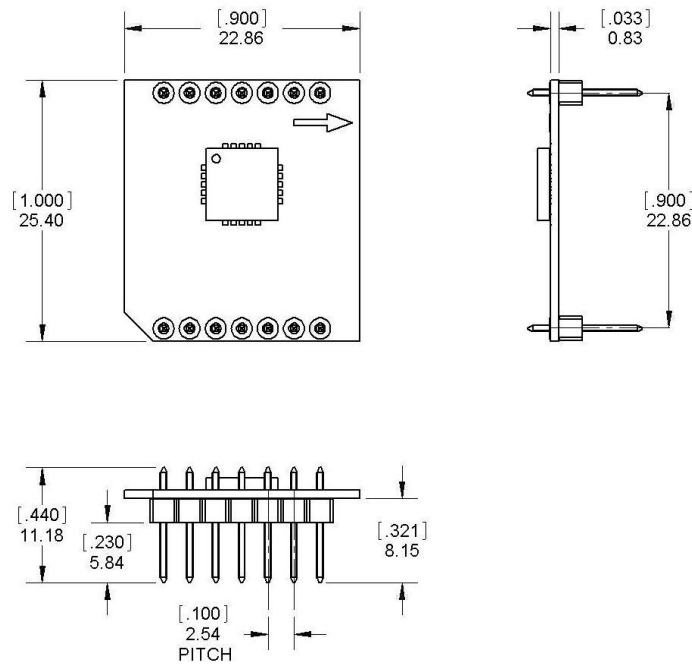

Figure 9: MS2100 Carrier Board Mechanical Drawing

## Recommended Processing Parameters

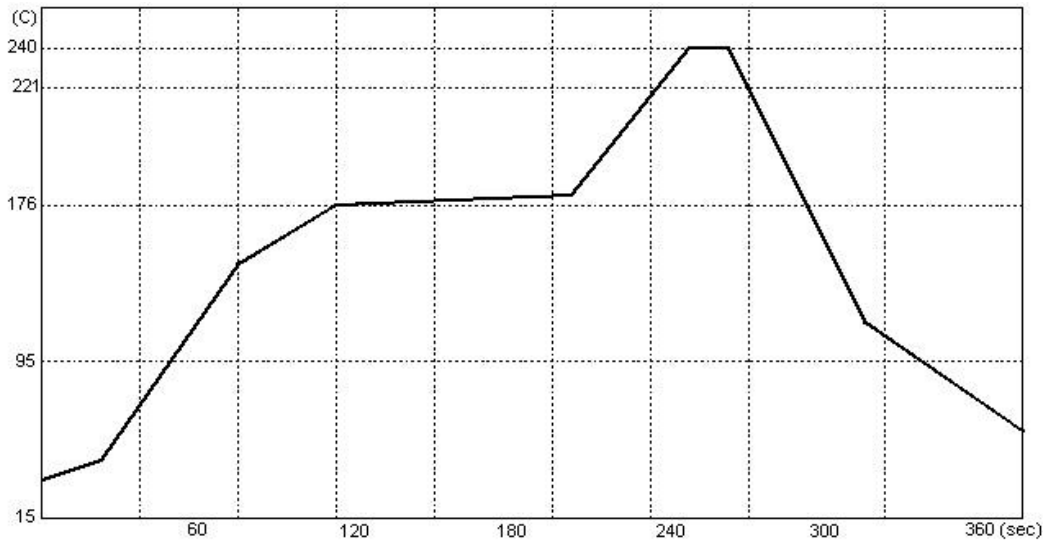

Figure 10: MS2100 Solder Profile

Table 11: Recommended Processing Parameters

Reflow Parameter	Temperature	Time
Max Peak Temperature	240°C	
Soak Time at Peak Temperature		10-20 seconds
Ramp Down Rate	4°C/second max	
Solder Melting Point	>218°C	
Moisture Sensitivity Level: Refer to handling instructions below.		

### Instructions for baking of PNI MS2100 Components prior to SMT

The MS2100 is shipped in a moisture resistant sealed tray containing 416 pcs (p/n 12913) or in partial trays or smaller packages of 415 or fewer pcs (p/n 12913P) which are not sealed.

To mitigate the risk of moisture damage, PNI recommends the following procedure for all MS2100s:

- 1) Peak package body temperature: 240 C
- 2) After the moisture seal is opened, MS2100s must be baked at 125 C (+/- 5 C) for 24 hours prior to being subjected to reflow solder or other high-temperature processes. After this bake process is complete, the MS2100 must be mounted within 8 hours (assuming factory conditions of temperature < 30°C and humidity (RH) < 60% are not exceeded).
- 3) Unused MS2100s are to be stored in their trays and sealed. Bake as stipulated in step #2 above before use.

Note: Temperature and humidity defined by IPC/JEDEC J-STD-020