

### Introduction

This application note describes how to use a Kionix MEMS tri-axis accelerometer as part of a warranty protection system. The system will record free-fall events or high-g events which might void warranty agreements. It can be integrated into a hand-held or portable electronic device or be used as an external module (in a shipping container, for example).

### Potential Warranty Protection System

Potentially, a warranty protection system can be created if the Kionix tri-axis accelerometer is integrated into a device with a micro-controller, flash memory, real time clock, and external serial communication (Fig. 1).

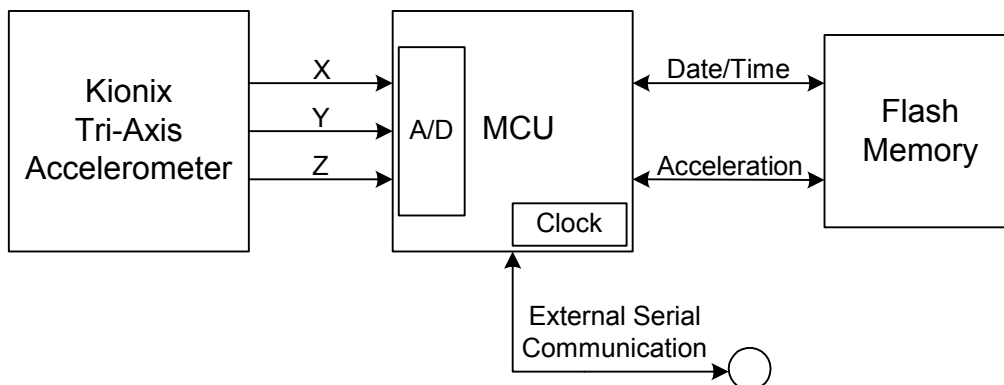

Fig. 1) Warranty Protection System Block Diagram

In this application, a continuous 2-second buffer of the accelerometer outputs can monitor the device, sampling at a low frequency to conserve power. If the accelerometer senses that the total acceleration has changed from the normal static 1g of acceleration, the device must be moving. The accelerometer starts sampling at a higher frequency and looks for preset event indicators such as accelerations below a low acceleration (free-fall) threshold or above a high acceleration threshold. Once an event or threshold crossing is detected, the previous 2 seconds worth of buffered data, plus an additional amount of follow on data, perhaps 6-seconds worth, can be permanently stored in memory with a date/time stamp. Therefore, documenting the entire event. This documented data can then be retrieved at a later date via serial communication and analyzed. After the event is recorded, the acceleration is compared to the thresholds to verify that the event is over. If it is, the accelerometer returns to sampling the acceleration. Please see the flowchart in Fig. 2 below:

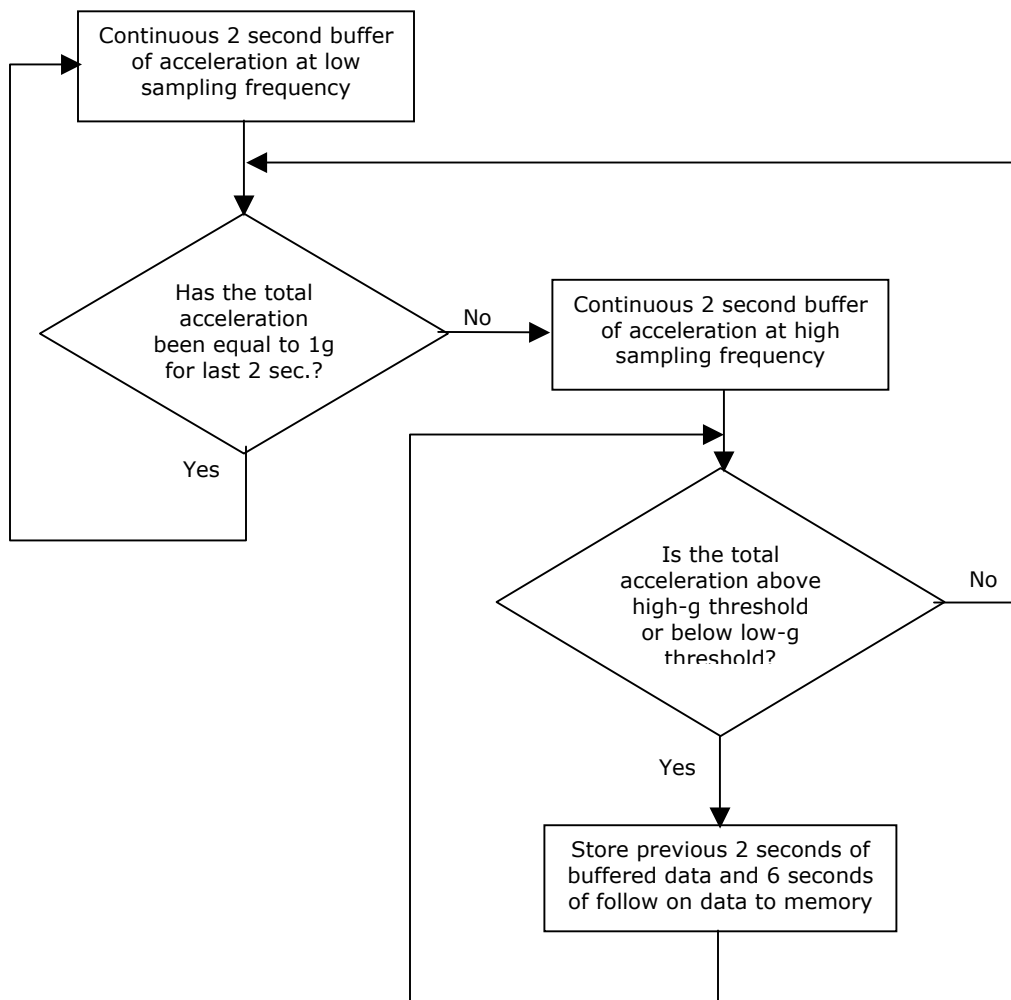

Fig. 2) Warranty protection flowchart

Now that an event history of the device has been created, if it is returned to the manufacturer for repair, the stored event signatures can help determine if the device was subjected to shock events that could potentially void the warranty.

As an example of such an event, Kionix performed drop tests and logged the total acceleration data for the entire event. The acceleration was plotted over time in order to observe the signature shown in Fig. 3 below. For this calculation, the total time in free-fall was considered to be the interval of time between the point at which the object crossed .5g on the way to free-fall to the point at which the object again crossed .5g upon impact.

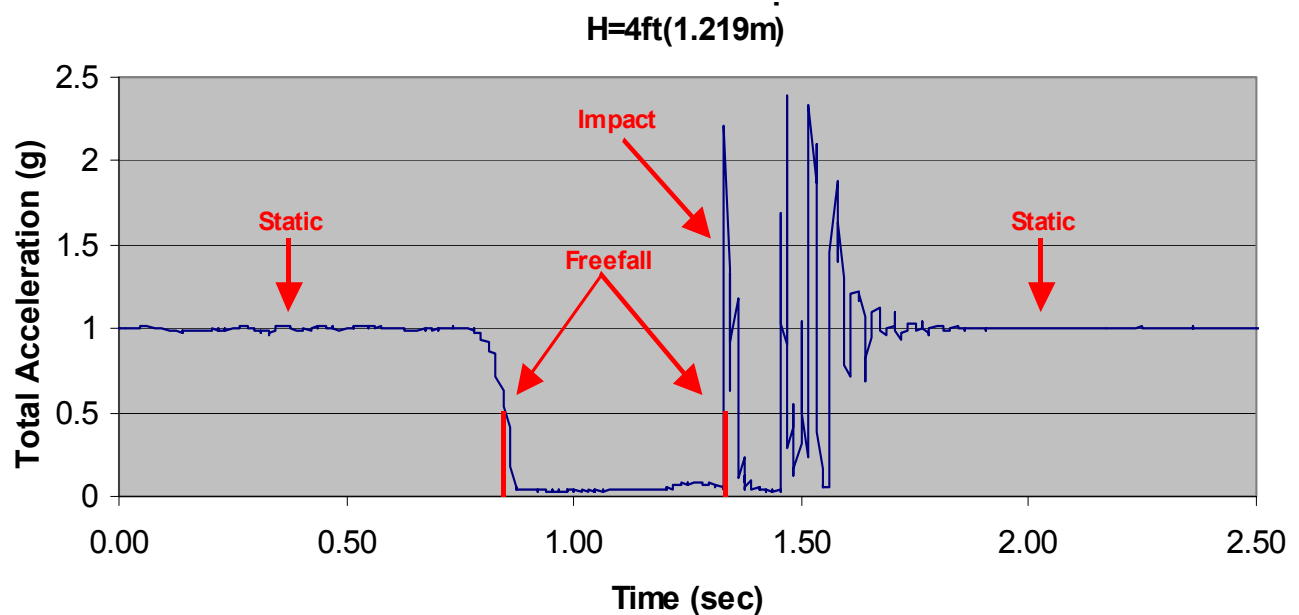

Fig. 3) Drop Signature

Based on the data collected, the free-fall time was .498 seconds. Eq. 1 can be used to calculate the height at which the object was released to free-fall. In this case, the object, in fact, did fall from a height of approximately 1.219m (4ft).

$$h = \frac{(gt^2)}{2}$$

Eq. 1)  $h$  = drop height (m),  $t$  = time (s),  $g = 9.8\text{m/s}^2$

As discussed in application note, "[AN 001 Free-fall Sensing for Drop-Force Modeling Using a Kionix MEMS Tri-Axis Accelerometer](#)", the approximate peak acceleration during this impact was 1700g.

From this data, for example, a claim could be made that a shipping container the unit was in or attached fell from a height of approximately 1.219m (4ft) which broke the fragile contents.

### The Kionix Advantage

A Kionix tri-axis accelerometer can be used successfully to characterize event signatures that may potentially void manufacturers warranties. Kionix technology provides for X, Y, and Z-axis sensing on a single, silicon chip. One accelerometer can be used to enable a variety of simultaneous features including, but not limited to:

Hard Disk Drive protection  
Vibration analysis  
Tilt screen navigation  
Sports modeling  
Theft, man-down, accident alarm  
Image stability, screen orientation & scrolling  
Computer pointer  
Navigation, mapping  
Game playing  
Automatic sleep mode

### **Theory of Operation**

Kionix MEMS linear tri-axis accelerometers function on the principle of differential capacitance. Acceleration causes displacement of a silicon structure resulting in a change in capacitance. A signal-conditioning CMOS technology ASIC detects and transforms changes in capacitance into an analog output voltage, which is proportional to acceleration. These outputs can then be sent to a micro-controller for integration into various applications. For product summaries, specifications, and schematics, please refer to the Kionix MEMS accelerometer product sheets at <http://www.kionix.com/sensors/accelerometer-products.html>.