

User Manual

MB-73310

The MB-73310 is a PC/104-Plus module with onboard Atom processor D2550 or N2600, Intel ICH10R chipset, DDR3 up to 2GB, 2 x Giga LAN, Onboard VGA, LVDS, SATA, CF socket, 4 x USB, 2 x COM, GPIO, DC 5V input.

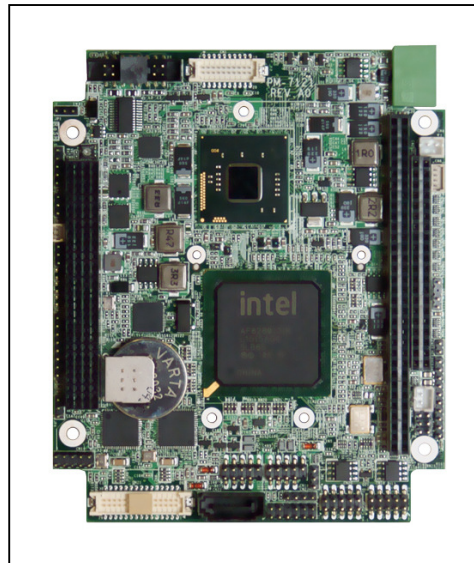

Ver.	Release Date	Update
1.0	2012.06.28	Release
1.1	2012.08.16	



Custom Embedded Solutions

Copyright

The content of this document and software with this product are copyrighted by WIN Enterprises.

This document contains proprietary information protected by copyright. All rights are reserved; no part of this manual may be reproduced, copied, translated or transmitted in any form or by any means without prior written permission of the manufacturer.

The content of this document is intended to be accurate and reliable. The original manufacturer assumes no responsibility for any inaccuracies that may be contained in this manual. The original manufacturer reserves the right to make improvements to the products described in this manual at any time without prior notice.

Trademark

All other product names mentioned herein are used for identification purpose only and may be trademarks and/or registered trademarks of their respective companies.

Limitation of liability

While reasonable efforts have been made to ensure the accuracy of this document, the manufacturer and distributor assume no liability resulting from errors or omissions in this document, or from the use of the information contained herein.

For more information or other WIN Enterprises products, please visit our website <http://www.win-ent.com>.

For technical support send inquiries to sales@win-ent.com.

Packing list

Before using this product make sure the following materials have been shipped.

- ▶ 1 x MB-73310 PC/104-Plus board
- ▶ 1 x CPU cooling Fan (p/n: CB-F000047-0)
- ▶ 1 x VGA cable (p/n: CB IVGA01-00)
- ▶ 1 x COM port cable (p/n: CB -ICOM25-00)
- ▶ 1 x LAN cable (p/n: CB -ILAN10-00)
- ▶ 1 x LAN module (p/n: R214A)
- ▶ 1 x USB cable (p/n: CB -IUSB03-00)
- ▶ 1 x Power cable (p/n: CB-IPOW82-01)
- ▶ 1 x CD Utility (p/n: TBD)

* If any items are missing or damaged contact your sales representative or distributor.

Model Name	Description
MB-7331A	PC/104-Plus with Atom D2550, onboard VGA, LVDS, 2x Giga LAN, COM, USB, SATA, CF socket, DC 5V input
MB-7331B	PC/104-Plus with Atom N2600, onboard VGA, LVDS, 2x Giga LAN, COM, USB, SATA, CF socket, DC 5V input.
MB-7331C	PC/104-Plus with Atom D2550, onboard VGA, LVDS, 2x Giga LAN, COM, USB, SATA, CF socket, DC 5V input. (Pin Down Type)
MB-7331D	PC/104-Plus with Atom N2600, onboard VGA, LVDS, 2x Giga LAN, COM, USB, SATA, CF socket, DC 5V input. (Pin Down Type)

Optional Accessories

- Audio daughter board (p/n: IP-90340)
- Audio cable connect daughter board & MB-73310 (p/n: CB-IDE18-00)



Safety Information

- To prevent electrical shock hazard, disconnect the power cable from the electrical outlet before moving the system.
- When adding or removing devices to or from the system ensure that the power cables for the devices are unplugged before the signal cables are connected. If possible, disconnect all power cables from the existing system before you add a device.
- Before connecting or removing signal cables from the motherboard ensure all power cables are unplugged.
- Seek expert assistance before using an adapter or extension cord. These devices could interrupt the grounding circuit.
- Make sure that your power supply is set to the correct voltage for your area.
- If you are not sure about the voltage of the electrical outlet you are using, contact your local power company.
- If the power supply is broken, do not try to fix it by yourself. Contact a qualified service technician or your retailer.

Operation Safety

- Before installing the motherboard and adding devices to it carefully read all the manuals that came with the package.
- Before using the product make sure all cables are correctly connected and the power cables are not damaged. If you detect any damage contact your dealer immediately.
- To avoid short circuits, keep paper clips, screws and staples away from connectors, slots, sockets and circuitry.
- Avoid dust, humidity, and temperature extremes. Do not place the product in any area where it may become wet.
- Place the product on a stable surface.
- If you encounter technical problems with the product contact a qualified service technician or your retailer.

Contents

Chapter 1	General Information	5
1.1	Introduction	7
1.2	Specifications.....	8
1.3	Block diagram	9
1.4	Board layout dimensions	10
1.5	I/O connectors	11
Chapter 2	Hardware installation	12
2.1	The location of onboard connectors	12
2.2	The location of onboard jumpers	13
2.3	The function list of onboard jumpers setting	14
2.3.1	JP1 for LVDS Panel Vcc select.....	14
2.3.2	JP2 for PCI-104 Vio voltage select.....	15
2.3.3	JP3 for watchdog timer select	15
2.3.4	JP4 for Clean CMOS.....	16
2.3.5	JP5 for COM2 select	17
2.3.6	JP6 for AT & ATX mode select.....	18
2.4	The pin define of onboard pin header	19
2.4.1	CN1 for LVDS connector.....	19
2.4.2	CN2 for VGA pin header	20
2.4.3	CN3 for +5V DC input.....	21
2.4.4	CN4 for +12V DC input.....	21
2.4.5	CN5 for LVDS Backlight control	22
2.4.6	CN6 for +5V_SB DC input & PS_ON.....	22
2.4.7	CN9 for -5V & -12V DC input	23
2.4.8	CN10 for front panel.....	24
	CN11 for power button	24
2.4.9	CN12 for fan connector	25
	CN13 for GPIO.....	25



2.4.10	CN14 for LPC connector.....	26
	CN15 for battery connector	26
2.4.11	CN16 for USB 2/3.....	27
	CN17 for USB 0/1	27
2.4.12	CN18 for COM2 (422/485).....	28
	CN19 for COM1 (RS232)	28
2.4.13	CN20 for COM2 (RS232)	29
2.4.14	CN21 for LAN1 & LAN2.....	30
2.4.15	CN23 for HDA connector.....	31

Chapter 3 Programming WDT & GPIO30

3.1	GPIO DOS sample code	32
3.2	WatchDog timer DOS sample code	39



1.1 Introduction

MB-73310 is a PC/104-Plus with onboard Intel® Atom™ processor and Intel® ICH10R chipset, Intel® Atom™ N2600 is a dual core processor which Clocked at 1.60 GHz, the power consumption of N2600 processor only 3.5 watt (Atom™ D2550 for 10W TDP) and it is good for application which need high-performance at low energy-consumption levels, such as medical devices, Digital Signage, Information Kiosk, Point-of-Sale, Gaming machines and Industrial control systems.

MB-73310 supports dual display for VGA + LVDS, the Atom processor also built-in graphics (GMA 3650) and a video decoding engine for MPEG4 Part2, VC-1, WMV9, and H.264. The integrated 64Bit Single-Channel DDR3-800/1067 memory controller supports one SODIMM and a maximum of 2GB RAM.

Onboard Intel® ICH 10R chipset provides extensive IO ports support, including 1x SATAII interface with 300MB/s transfer rate, 4x USB 2.0, HD Audio, onboard 2x Gigabit Ethernet provided by Intel® 82583V Gigabit Ethernet. 1x RS232/422/485 & 1x RS232, 8-bit GPIO and 1x CompactFlash socket support Type-2 CompactFlash card.

WIN Enterprises' MB-73310 support PC/104-Plus module and accept single DC 5V input for operating.

WIN ENTERPRISES offers reliable and solid products which are produced under Management System Standards: ISO9001-2000 Certificate. The certificate keeps us focused on our quality objectives of management and environmental production. Its willingness to customize standard products for meet unique customer needs makes WIN ENTERPRISES different. All ODM projects are welcome. Years of experiences enables WIN ENTERPRISES to fulfill the customer's vision, by delivering products to exact specifications. WIN ENTERPRISES R&D team is proud of its strong engineering background. R&D professionals account for 25% of the WIN ENTERPRISES workforce. We focus on developing new products for both emerging and established markets

For more information about OEM/ODM, please contact us at:

Email: sales@win-ent.com

TEL: +1 (978) 688-2000



1.2 Specifications

Form Factor	PC/104-Plus
CPU	Onboard Intel® Atom processor D2550 1.86 GHz Onboard Intel® Atom processor N2600 1.60 GHz
Chipset	Intel® ICH10R chipset
Memory	1x DDR3 800/1066 MHz SO-DIMM up to 2GB
BIOS	AMI® SPI BIOS
Watchdog Timer	255 levels timer interval, (1 ~ 255 seconds), setup by software
Integrated graphics	Intel® Cedarview integrated graphic
VGA interface	1x internal VGA connector
LVDS interface	1x 18/24-bit single channel LVDS interface (D2550) 1x 18-bit single channel LVDS interface (N2600)
SATA interface	1x SATAII up to 300 MB/s
SSD interface	1x CompactFlash socket
Ethernet	2x Intel® i211AT or i210AT Gigabit Ethernet
Expansion interface	1x PC/104-Plus
COM	1x RS422/485 , 1 x RS232
USB	4x USB 2.0
Audio	1x HDA audio pin-header (need to purchase Audio module to work with)
GPIO	8-bit programmable GPIO interface
Power Input	Single DC 5V input
Board Size	96 mm x 116 mm
Operating temperature	0°C ~ 60°C

Note: Specifications and photos subject to change without prior notice.

1.3 Block Diagram

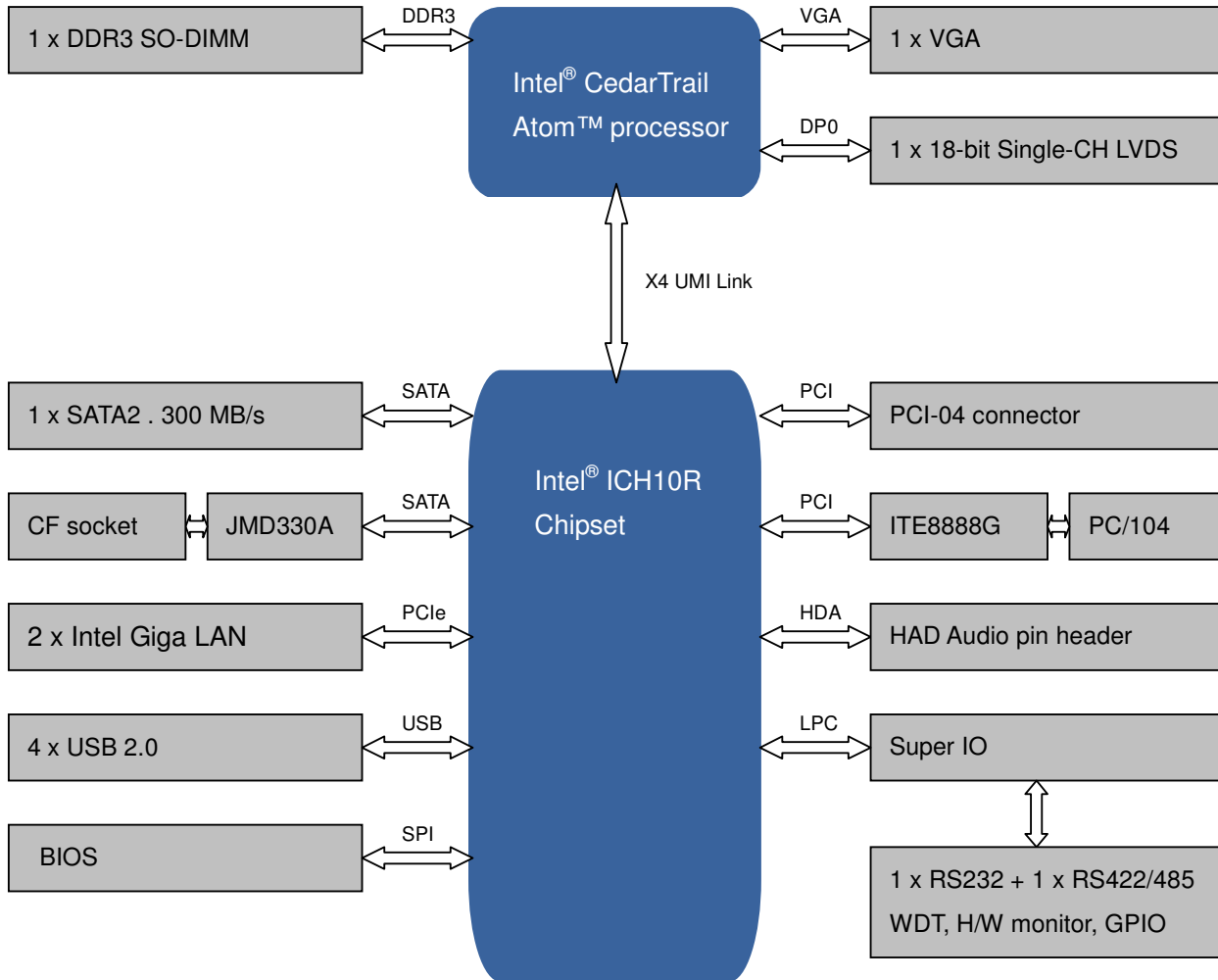

1.4 Board Dimensions

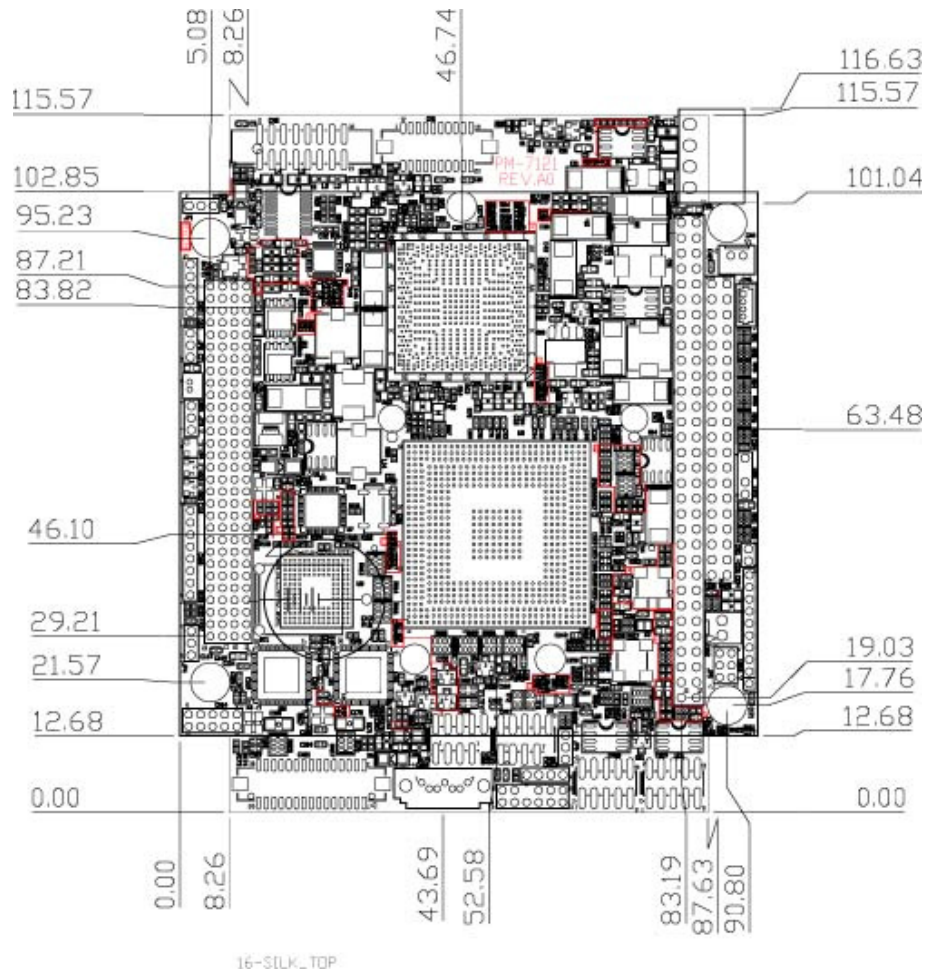

1.5 I/O Ports

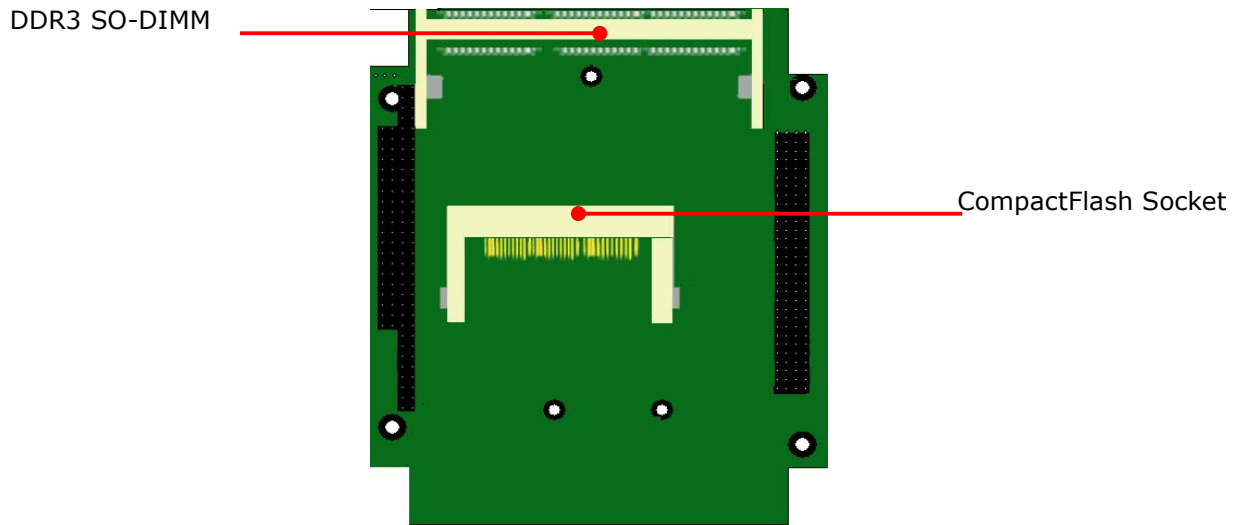
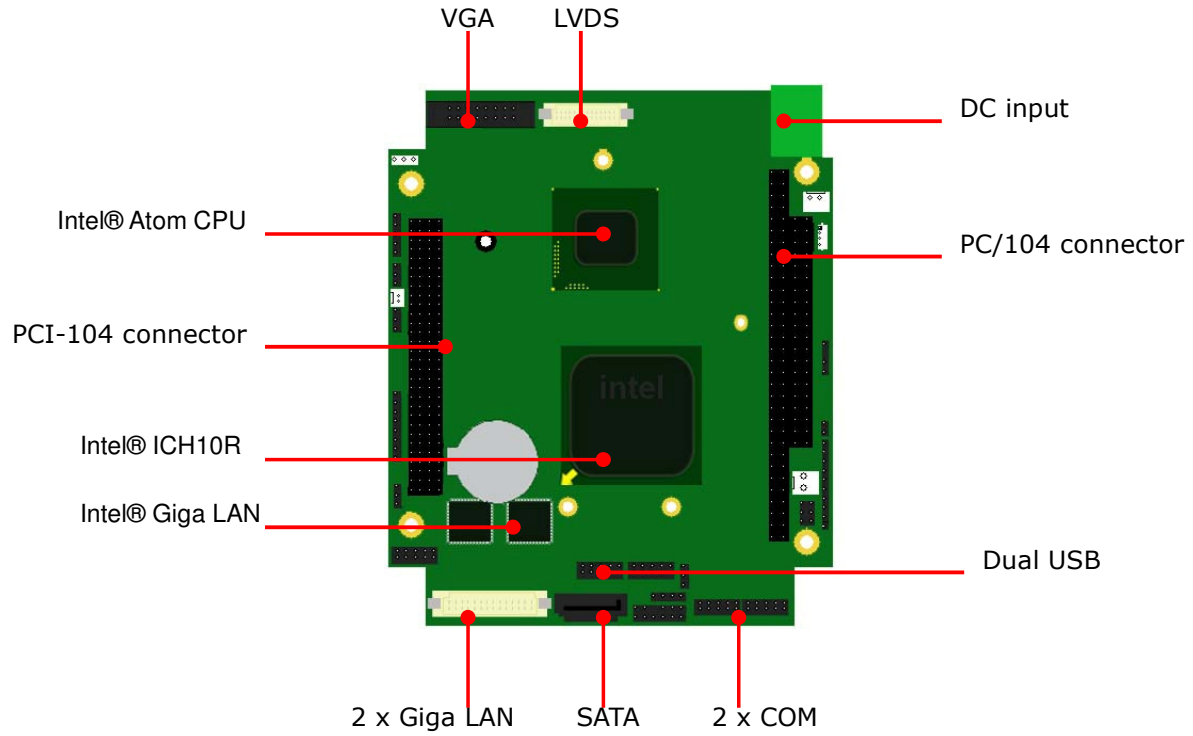

2.1 The location of onboard connectors

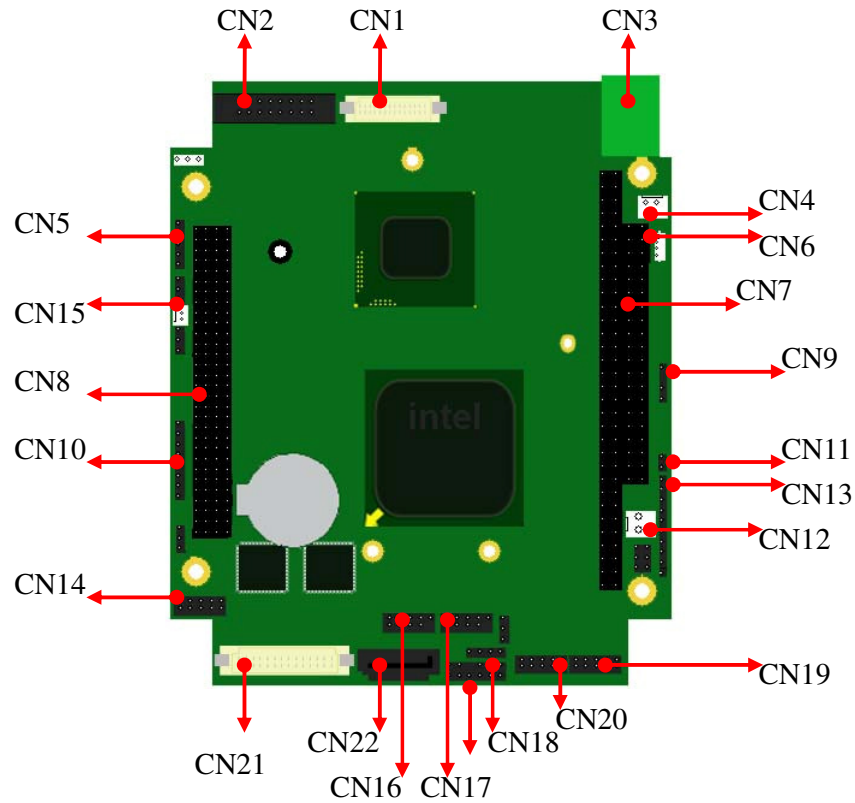

Label	Function	Label	Function
CN1	LVDS connector	CN15	Battery connector
CN2	VGA connector	CN16	USB ports 2/3
CN3	+5V DC input	CN17	USB ports 0/1
CN4	+12V DC input	CN18	COM2 (RS422 / 485) connector
CN5	LVDS backlight control	CN19	COM1 (RS232) connector
CN6	+5V_SB DC input and PS_ON	CN20	COM2 (RS232) connector
CN7	PC/104 connector	CN21	LAN1 , LAN2 connector
CN8	PCI-104 connector	CN22	SATA connector
CN9	-12V / -5V DC input	CN23	HAD connector
CN10	Front Panel	DIMM	1 x SO-DIMM on solder-side
CN11	Power Button	CF1	1 x CompactFlash socket on solder-side
CN12	FAN connector		
CN13	GPIO pin header		
CN14	LPC connector		

2.2 The location of onboard jumpers

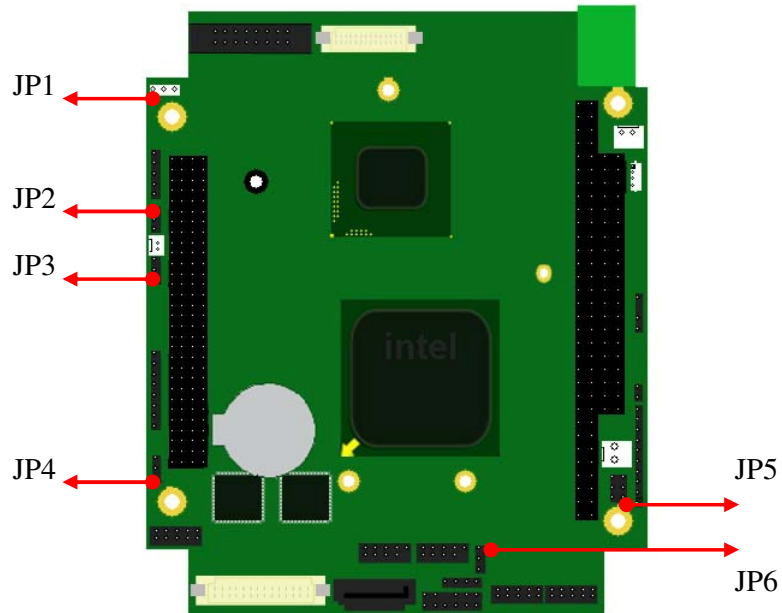

Label	Function
JP1	Panel Voltage (VCC) select
JP2	PCI-104 Vio select
JP3	WDT select
JP4	Clear CMOS
JP5	COM2 select
JP6	AT & ATX mode select

2.3 The function list of onboard jumpers setting

- 2.3.1: JP1 for LVDS Panel Vcc select

JP1	
Closed Pin	Result
1-2 *	+3.3V
2-3	+5V

* Default setting

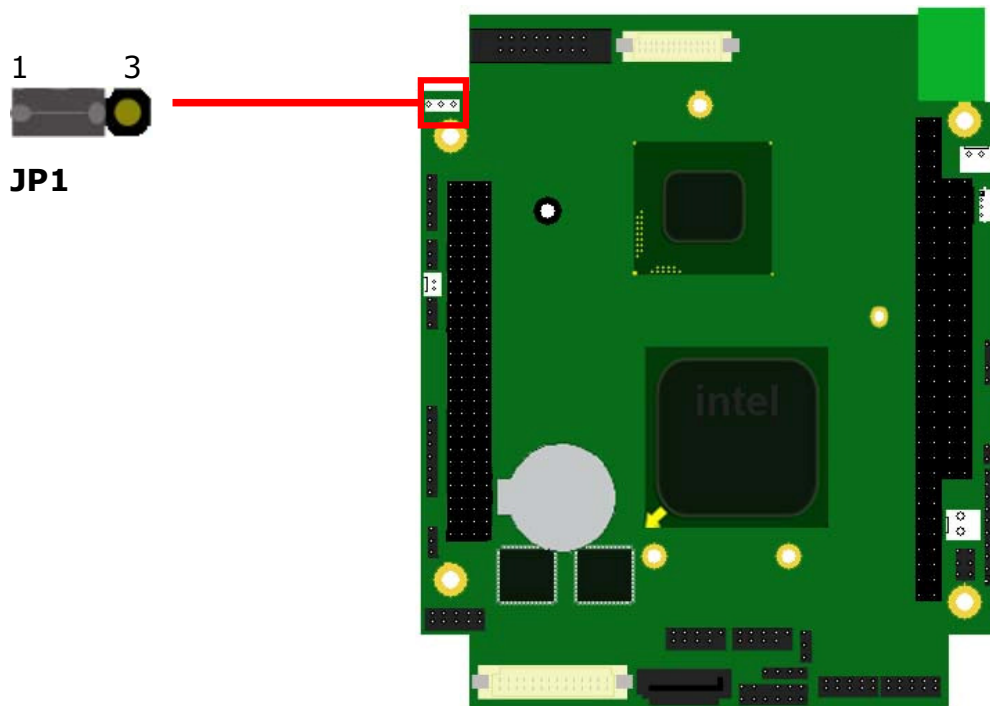

- 2.3.2: JP2 for PCI-104 Vio select

JP2	
Closed Pin	Result
1-2	+5V
2-3 *	+3.3V

* Default setting

- 2.3.3: JP3 for WDT select

JP3	
Closed Pin	Result
1-2	+5V
2-3 *	+3.3V

* Default setting

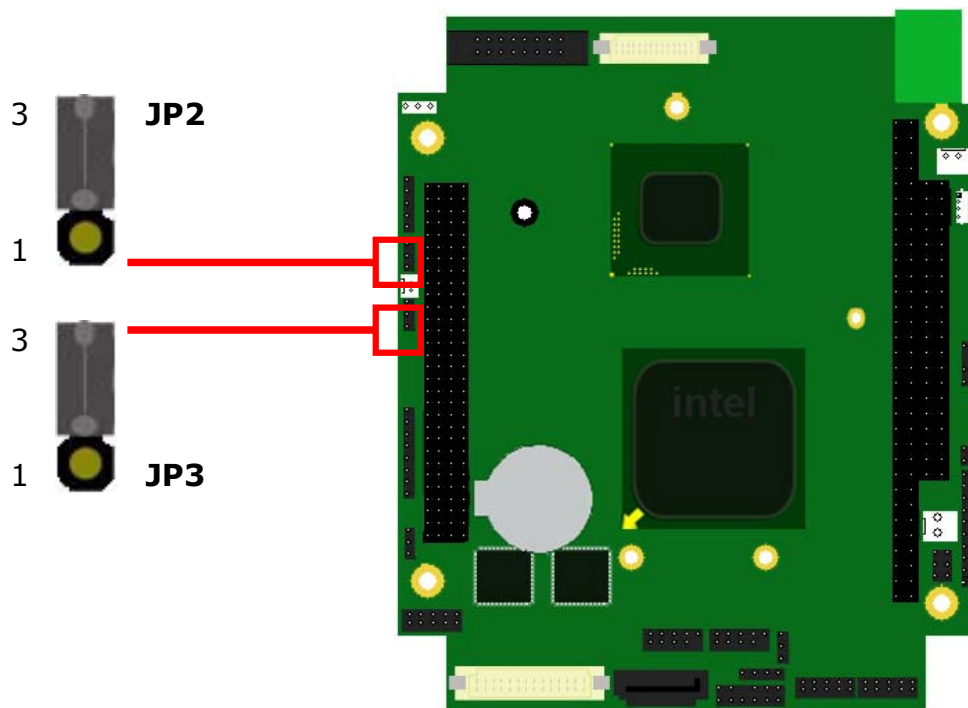

- 2.3.4 : JP4 for Clear CMOS

If you want to clean the CMOS data, set jumper to 2-3 for a few seconds. Then, move the jumper back to 1-2 pin

JP4	
Closed Pin	Result
1-2 *	Normal
2-3	Clear CMOS

* Default setting

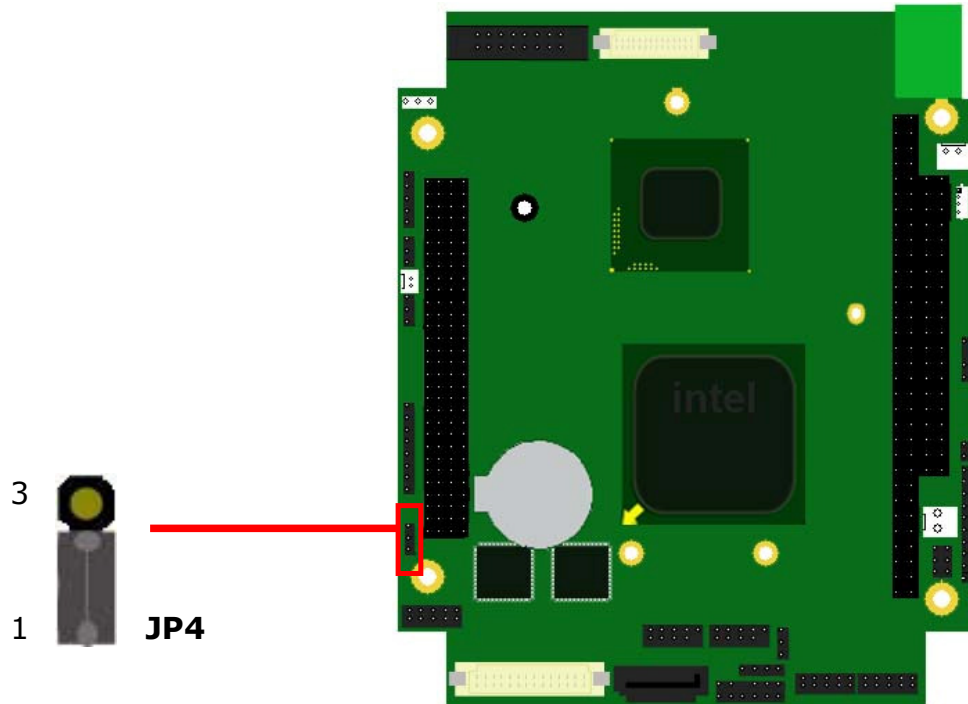

- 2.3.5: JP5 for COM2 select

JP5	
Closed Pin	Result
1-2 *	RS232
2-3	RS422
5-6	RS485

* Default setting

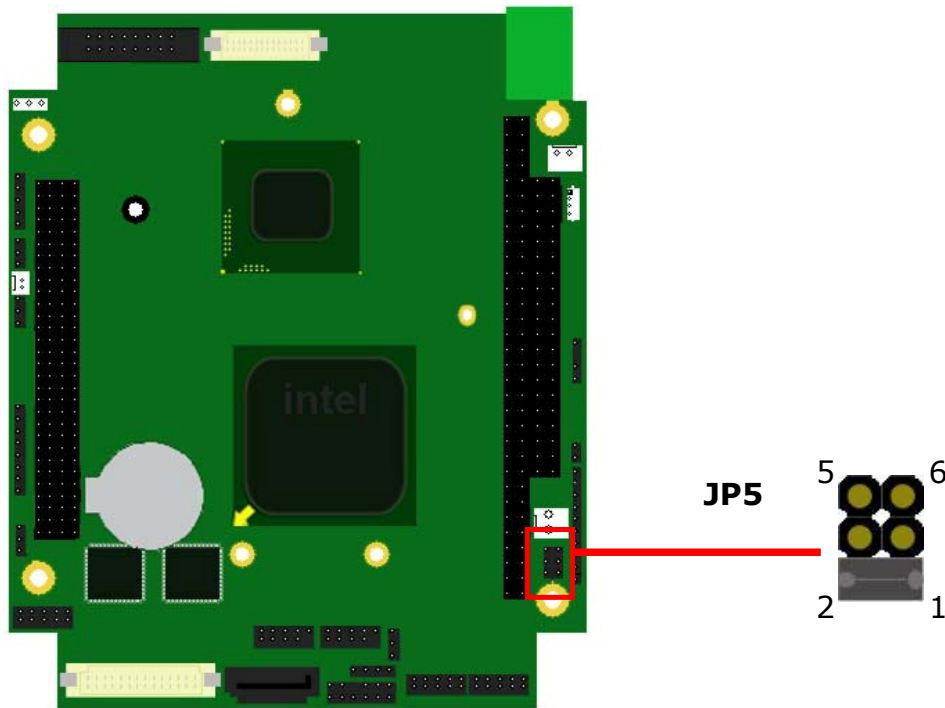

- 2.3.6: JP6 for AT/ATX mode select

JP6	
Closed Pin	Result
1-2 *	ATX mode
2-3	AT mode

* Default setting

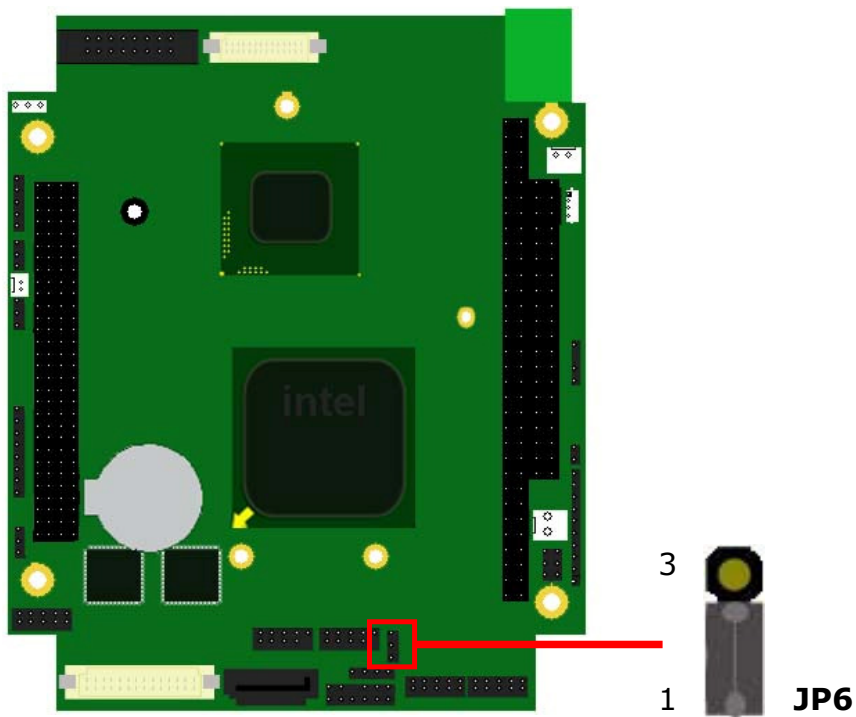

2.4 The pin define of onboard pin header

- 2.4.1: CN1 for LVDS connector

CN6 : 2 x 10 header , connector type : DF13A-20DP-1.25V			
Pin	Signal	Pin	Signal
1	TXP0	2	TXN0
3	GND	4	GND
5	TXP1	6	TXN1
7	GND	8	VCC_LCD
9	TXP2	10	TXN2
11	CLKP	12	CLKN
13	GND	14	GND
15	TXP3	16	TXN3
17	LBKLT_EN_DELAY	18	VCC_LCD
19	DDC_DATA	20	DDC_CLK

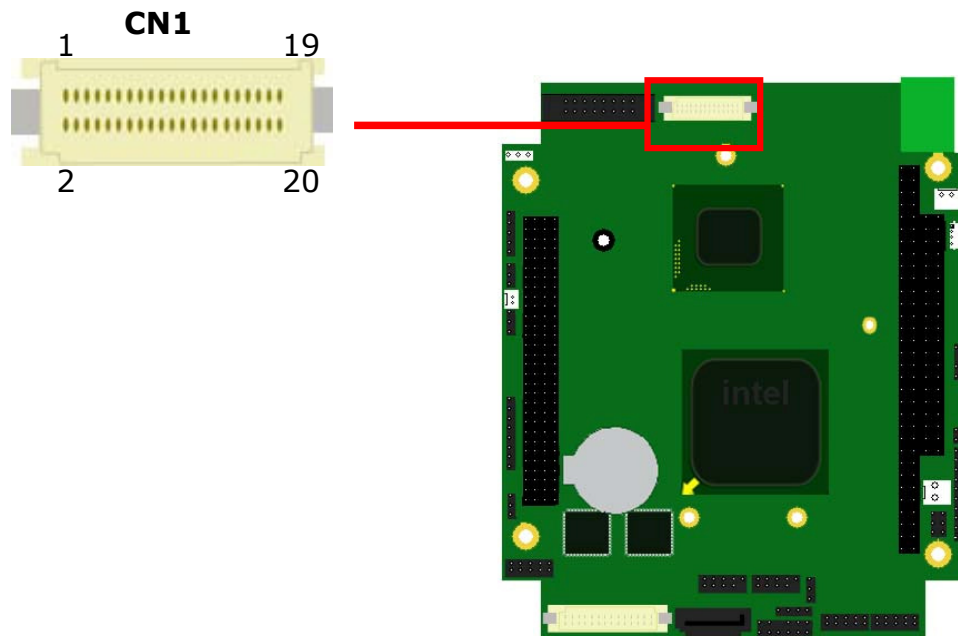

- 2.4.2: CN2 for VGA connector

CN7 : 2 x 8 header , pitch 2.00 mm			
Pin	Signal	Pin	Signal
1	CRT_RED	2	CRT_GREEN
3	CRT_BLUE	4	+5VP0
5	GND	6	GND
7	GND	8	GND
9	+V_CRTCON	10	GND
11	V5P0	12	CRT_DDC_SDA
13	CRT_HSYNC	14	CRT_VSYNC
15	CRT_DDC_SLC	16	N/C

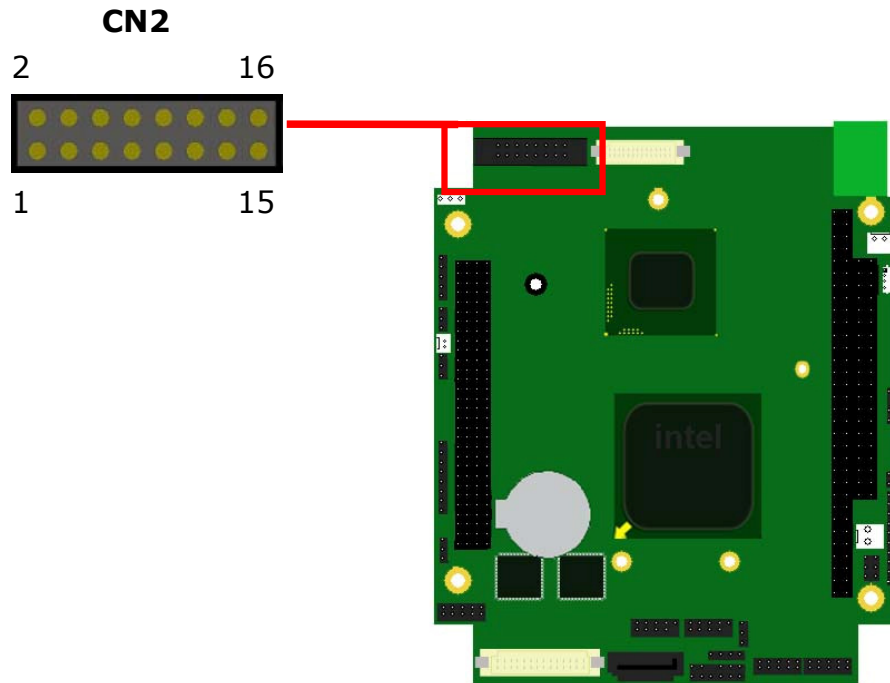

- 2.4.3: CN3 for +5V DC input

CN9 : 1 x 4 header			
Pin	Signal	Pin	Signal
1	+V5P0	2	+V5P0
3	GND	4	GND

- 2.4.4: CN4 for +12V DC input

CN12 : 1 x 2 header , pitch 2.00 mm			
Pin	Signal	Pin	Signal
1	+12VP0	2	GND

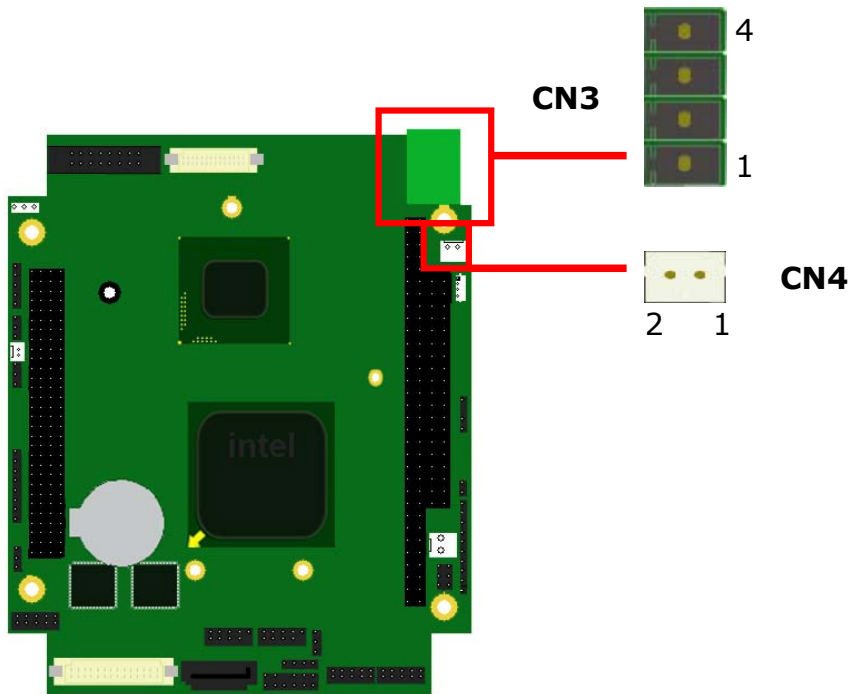

- 2.4.5: CN5 for LVDS Backlight Control

CN12 : 1 x 5 header , pitch 2.00 mm			
Pin	Signal	Pin	Signal
1	+12VP0	2	GND
3	LBKLT_EN_DELAY	4	LCD_BKB_CTRL
5	+5VP0		

- 2.4.6: CN6 for +5V_SB DC input and PS_ON

CN13 : 1 x 4 header , pitch 2.0 mm			
Pin	Signal	Pin	Signal
1	+V5P0	2	+V5P0
3	GND	4	PS_ON

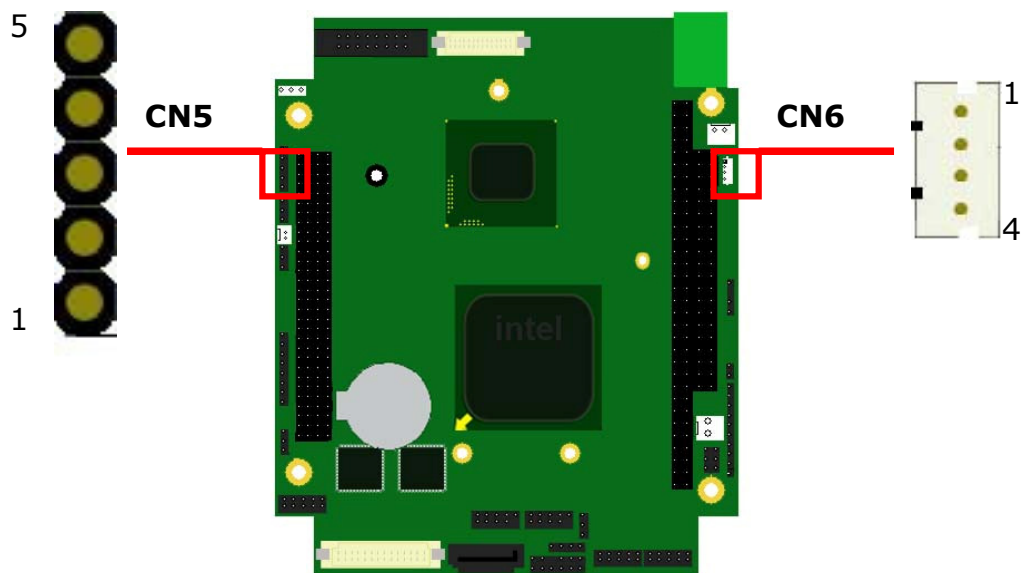

- 2.4.7 : CN9 for -5V & -12V DC input

CN13 : 1 x 4 header , pitch 2.0 mm			
Pin	Signal	Pin	Signal
1	-V5P0	2	GND
3	N/C	4	-V12P0

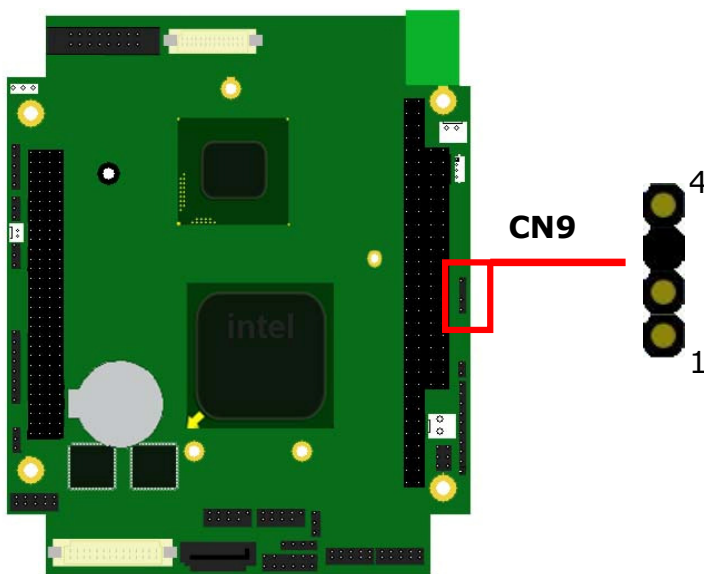

- 2.4.8: CN10 for Front Panel

CN14 : 1 x 8 header , pitch 2.0 mm			
Pin	Signal	Pin	Signal
1	PWR_LED_N	2	GND
3	HDD_LED+	4	HDD_LE-
5	SYSRST_N	6	GND
7	SPKR_PU	8	BEEP_SPKR_R_N

CN11 for Power Button

CN15 : 1 x 2 header , pitch 2.0 mm			
Pin	Signal	Pin	Signal
1	PWRSW	2	GND

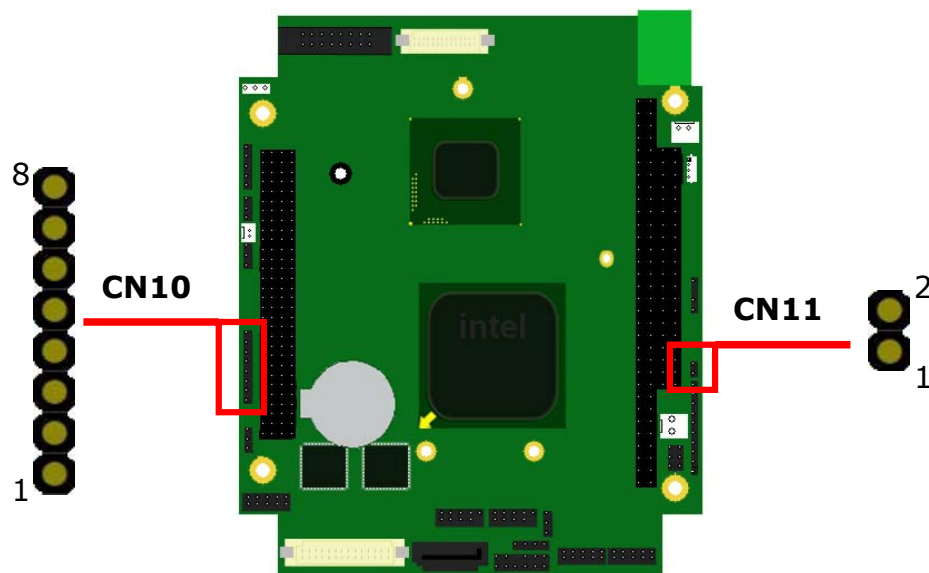

- 2.4.9 : CN12 for Fan connector

CN17 : 1 x 2 header , pitch 2.0 mm			
Pin	Signal	Pin	Signal
1	+V5P0	2	GND

CN13 for GPIO ports

CN15 : 1 x 10 header , pitch 2.0 mm			
Pin	Signal	Pin	Signal
1	+V3P3	2	GPIO10
3	GPIO11	4	GPIO12
5	GPIO13	6	GPIO14
7	GPIO15	8	GPIO16
9	GPIO17	10	GND

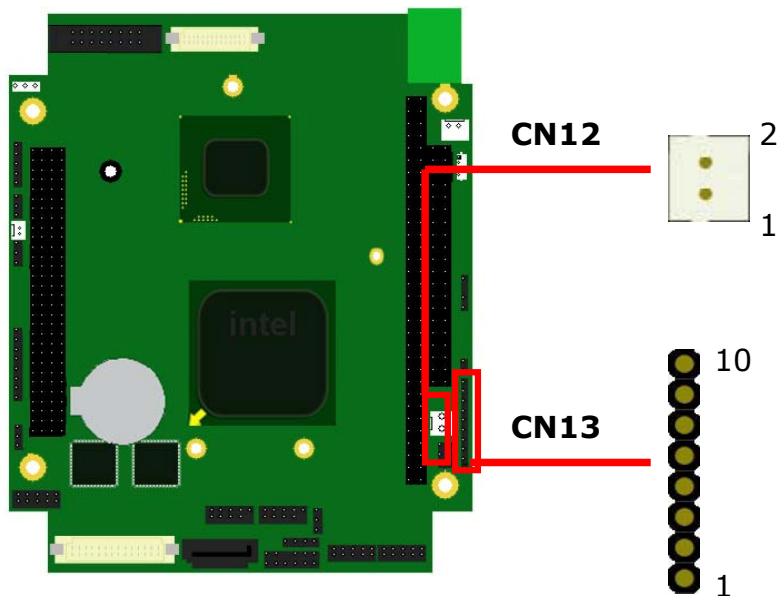

- 2.4.10 : CN14 for LPC connector

CN19 : 2 x 5 header , pitch 2.0 mm			
Pin	Signal	Pin	Signal
1	+V3P3	2	LAD0
3	LAD1	4	LAD2
5	LAD3	6	LFRAME_N
7	PLTRST_N	8	+5VP0
9	PORT80_PCLK	10	GND

CN15 for Battery connector

CN19 : 1 x 2 header , pitch 2.0 mm			
Pin	Signal	Pin	Signal
1	BAT2_R	2	GND

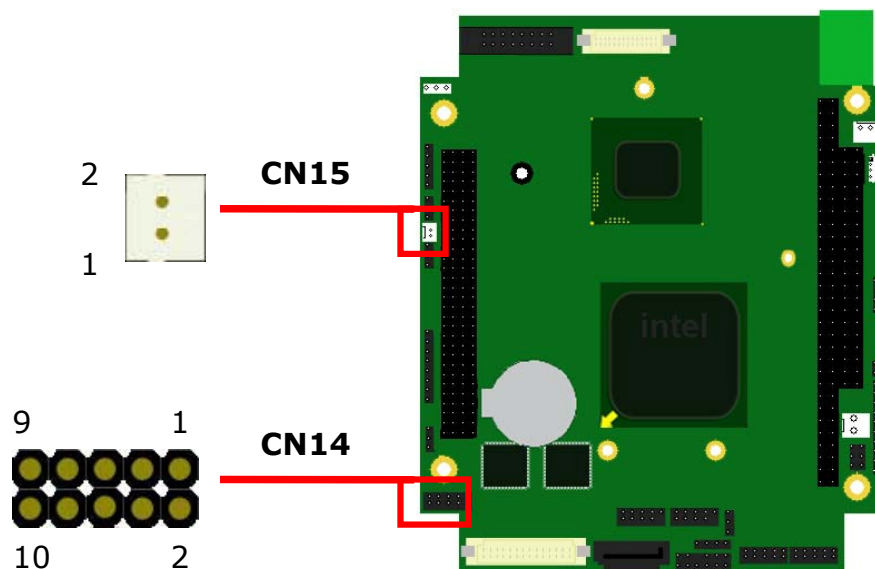

- 2.4.11: CN16 for USB2 & USB3

CN20 : 2 x 5 header , pitch 2.0 mm			
Pin	Signal	Pin	Signal
1	USBV23	2	USBV23
3	USB_PN_2	4	USB_PN_3
5	USB_PP_2	6	USB_PP_3
7	GND	8	GND
9	N/C	10	GND

CN17 for USB0 & USB1

CN20 : 2 x 5 header , pitch 2.0 mm			
Pin	Signal	Pin	Signal
1	USBV01	2	USBV01
3	USB_PN_0	4	USB_PN_1
5	USB_PP_1	6	USB_PP_1
7	GND	8	GND
9	N/C	10	GND

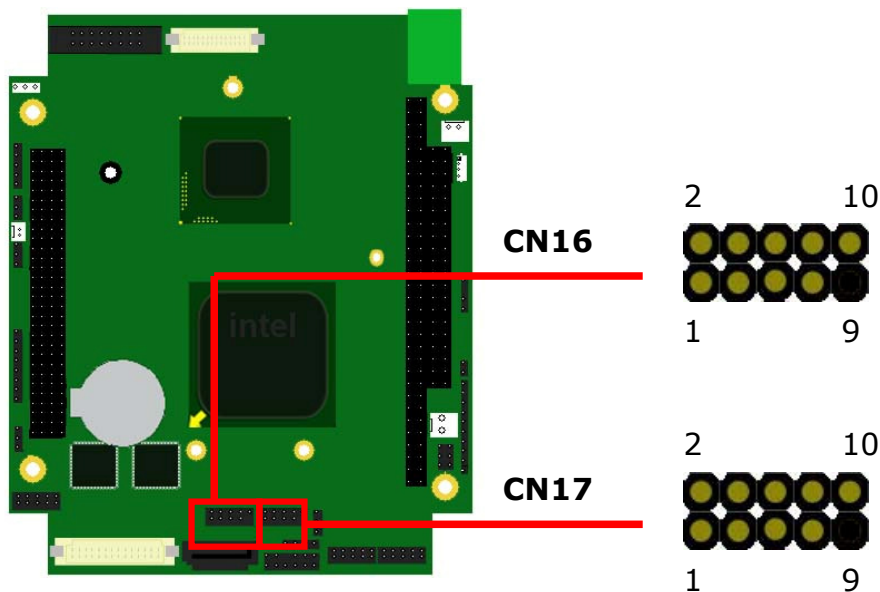

- 2.4.12: CN18 for COM2 (RS422/485) Connector

CN21 : 1 x 4 header , pitch 2.00 mm			
Pin	Signal	Pin	Signal
1	485_RXD-	2	485RXD+
3	485TXD+	4	485TXD-

CN19 for COM1 (RS232) Connector

CN21 : 2 x 5 header , pitch 2.00 mm			
Pin	Signal	Pin	Signal
1	DCD_N_CON	2	DSR_N_CON
3	_SIN_CON	4	RTS_N_CON
5	SOUT_CON	6	CTS_N_CON
7	DTR_N_CON	8	RI_N_CON
9	GND	10	N.C

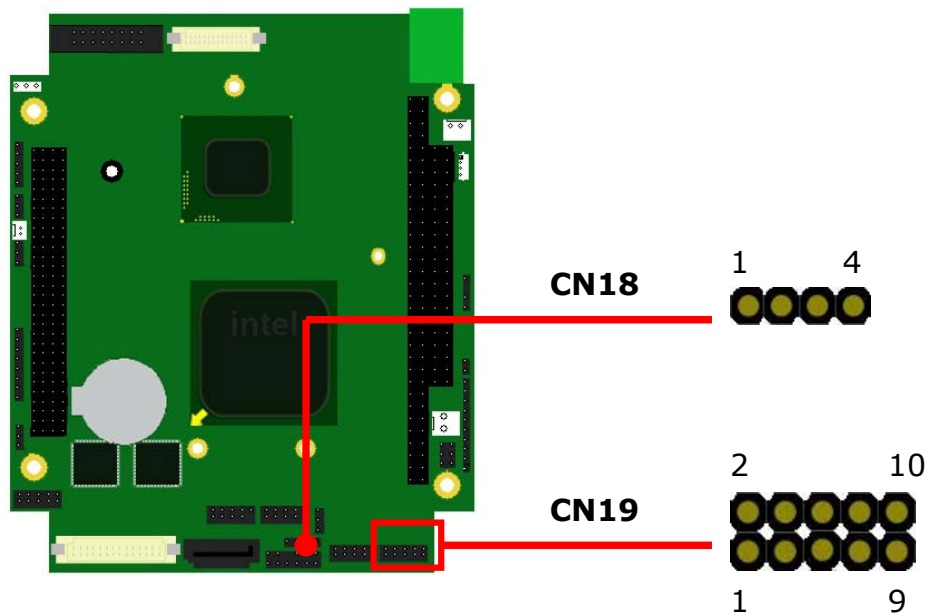

- 2.4.13: CN20 for COM2 (RS232) Connector

CN20 : 2 x 5 header , pitch 2.00 mm			
Pin	Signal	Pin	Signal
1	DCD_N_CON	2	DSR_N_CON
3	SIN_CON	4	RTS_N_CON
5	SOUT_CON	6	CTS_N_CON
7	DTR_N_CON	8	RI_N_CON
9	GND	10	N/C

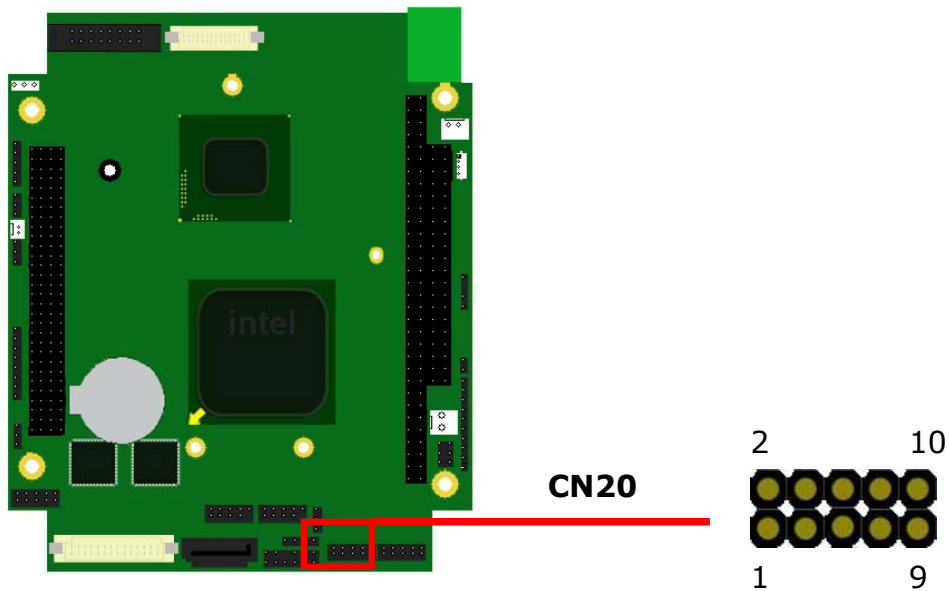

- 2.4.14: CN21 for LAN1, LAN2 Connector

CN20 : 2 x 15 header , connector type : DF13A-30DP-1.25V			
Pin	Signal	Pin	Signal
1	LAN1_L_MDIP2	2	LAN1_L_MDIP0
3	LAN1_L_MDIN2	4	LAN1_L_MDIN0
5	LAN1_L_MDIP3	6	LAN1_L_MDIP1
7	LAN1_L_MDIN3	8	LAN1_L_MDIN1
9	+V3P3	10	GND
11	LAN1_ACT_N_R	12	LAN1_LINK_N
13	LAN1_LINK100_N_R	14	LAN1_LINK1000_N
15	GND	16	GND
17	LAN2_L_MDIP0	18	LAN2_L_MDIP2
19	LAN2_L_MDIN0	20	LAN2_L_MDIN2
21	LAN2_L_MDIP1	22	LAN2_L_MDIP3
23	LAN2_L_MDIN1	24	LAN2_L_MDIN3
25	LAN2_ACT_N_R	26	LAN2_LINK_N
27	LAN2_LINK100_N	28	LAN2_LINK1000_N
29	GND	30	GND

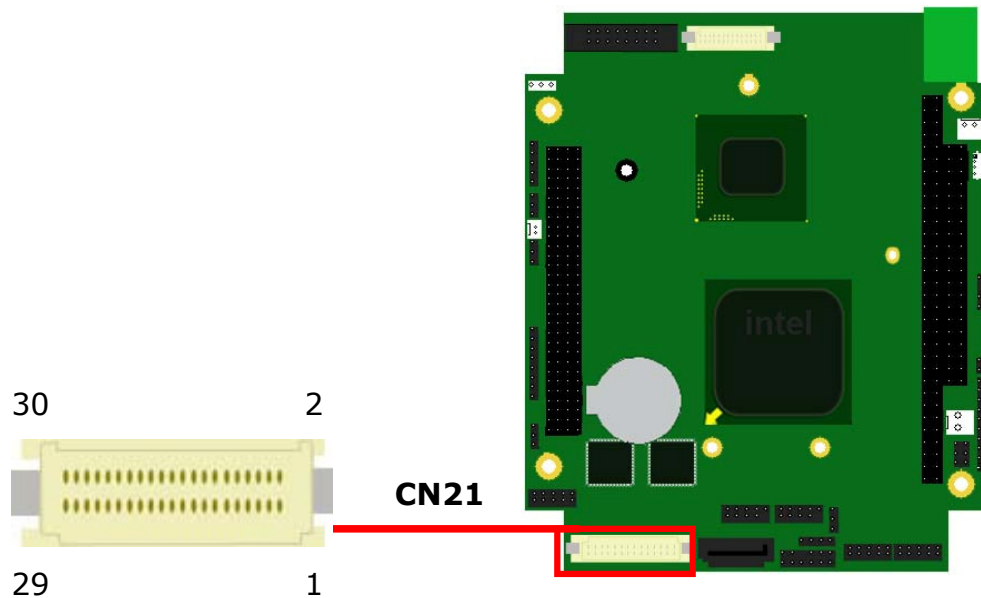

- 2.4.15: CN23 for HDA Connector

Note: You will need to purchase WIN Enterprises's audio module & cable to make audio function work

CN20 : 2 x 6 header , pitch 2.00 mm			
Pin	Signal	Pin	Signal
1	+V5P0	2	GND
3	GND	4	HDA_BIT_CLK
5	+V3P3	6	N/C
7	HDA_SDIN0	8	HDA_SYNC
9	GND	10	HDA_RST_N
11	HDA_SDOUT	12	HDA_SDIN1

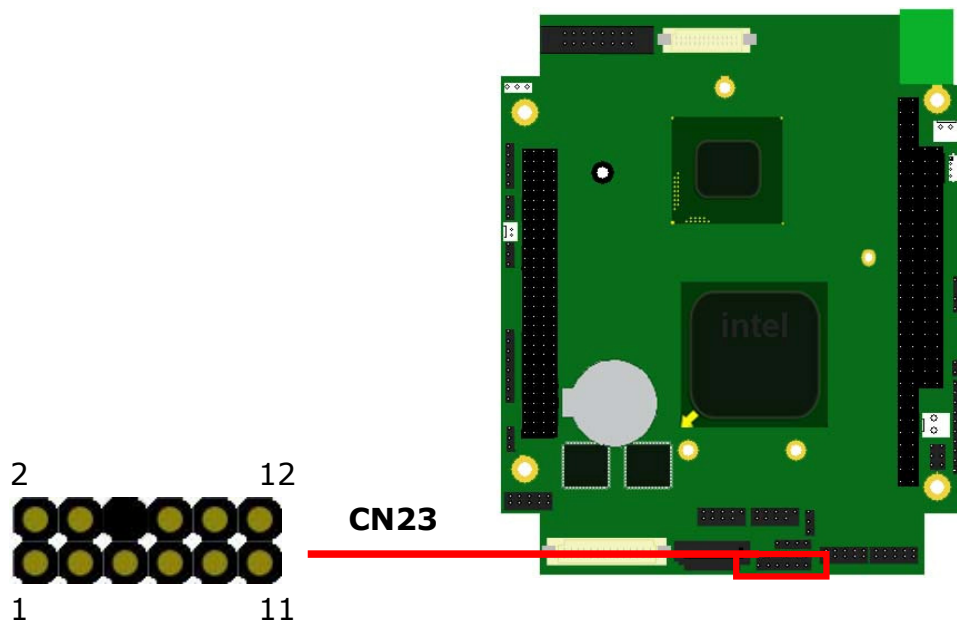



3.1 GPIO Sample Program for DOS environment

```
#include <stdio.h>
#include <string.h>
#include <dos.h>
#include <stdlib.h>
#include <inlines/pc.h>

#define index_port 0x2E           //Super IO Index port address
#define data_port 0x2F          //Super IO Data port address
#define GPIO_port 0x378
#define GPIO_read_port GPIO_port + 3

void Enter_sio_config();
void Exit_sio_config();
void ENABLE_GPIO();
void Input_mode();
void Output_mode();
void help();

int main(int argc, char *argv[])
{
    int data_rw8;

    if (argc<2){
        help();
        return;
    }

    ENABLE_GPIO();

    if(strcmp(argv[1], "-i") == 0){
        Input_mode();
        data_rw8 = inportb(GPIO_read_port);
        if ((data_rw8&0x01) == 0x00)
            printf("GPIO -> Low\n");
        else
```



Custom Embedded Solutions

```
printf("GPIO -> High\n");

if ((data_rw8&0x02) == 0x00)
    printf("GPI1 -> Low\n");
else
    printf("GPI1 -> High\n");

if ((data_rw8&0x04) == 0x00)
    printf("GPI2 -> Low\n");
else
    printf("GPI2 -> High\n");

if ((data_rw8&0x08) == 0x00)
    printf("GPI3 -> Low\n");
else
    printf("GPI3 -> High\n");

if ((data_rw8&0x10) == 0x00)
    printf("GPI4 -> Low\n");
else
    printf("GPI4 -> High\n");

if ((data_rw8&0x20) == 0x00)
    printf("GPI5 -> Low\n");
else
    printf("GPI5 -> High\n");

if ((data_rw8&0x40) == 0x00)
    printf("GPI6 -> Low\n");
else
    printf("GPI6 -> High\n");

if ((data_rw8&0x80) == 0x00)
    printf("GPI7 -> Low\n");
else
    printf("GPI7 -> High\n");

}
```

```
else if(strcmp(argv[1], "-h0") == 0){
    printf("GPO0 -> High\n");
    Output_mode();
    data_rw8 = inportb(GPIO_port)&0xFE;
    data_rw8 |= 0x01;
    outportb(GPIO_port, data_rw8);
}
else if(strcmp(argv[1], "-l0") == 0){
    printf("GPO0 -> Low\n");
    Output_mode();
    data_rw8 = inportb(GPIO_port)&0xFE;
    outportb(GPIO_port, data_rw8);
}

else if(strcmp(argv[1], "-h1") == 0){
    printf("GPO1 -> High\n");
    Output_mode();
    data_rw8 = inportb(GPIO_port)&0xFD;
    data_rw8 |= 0x02;
    outportb(GPIO_port, data_rw8);
}
else if(strcmp(argv[1], "-l1") == 0){
    printf("GPO1 -> Low\n");
    Output_mode();
    data_rw8 = inportb(GPIO_port)&0xFD;
    outportb(GPIO_port, data_rw8);
}

else if(strcmp(argv[1], "-h2") == 0){
    printf("GPO2 -> High\n");
    Output_mode();
    data_rw8 = inportb(GPIO_port)&0xFB;
    data_rw8 |= 0x04;
    outportb(GPIO_port, data_rw8);
}
else if(strcmp(argv[1], "-l2") == 0){
    printf("GPO2 -> Low\n");
```



Custom Embedded Solutions

```
Output_mode();
data_rw8 = inportb(GPIO_port)&0xFB;
outportb(GPIO_port, data_rw8);
}

else if(strcmp(argv[1], "-h3") == 0){
    printf("GPO3 -> High\n");
    Output_mode();
    data_rw8 = inportb(GPIO_port)&0xF7;
    data_rw8 |= 0x08;
    outportb(GPIO_port, data_rw8);
}

else if(strcmp(argv[1], "-l3") == 0){
    printf("GPO3 -> Low\n");
    Output_mode();
    data_rw8 = inportb(GPIO_port)&0xF7;
    outportb(GPIO_port, data_rw8);
}

else if(strcmp(argv[1], "-h4") == 0){
    printf("GPO4 -> High\n");
    Output_mode();
    data_rw8 = inportb(GPIO_port)&0xEF;
    data_rw8 |= 0x10;
    outportb(GPIO_port, data_rw8);
}

else if(strcmp(argv[1], "-l4") == 0){
    printf("GPO4 -> Low\n");
    Output_mode();
    data_rw8 = inportb(GPIO_port)&0xEF;
    outportb(GPIO_port, data_rw8);
}

else if(strcmp(argv[1], "-h5") == 0){
    printf("GPO5 -> High\n");
    Output_mode();
    data_rw8 = inportb(GPIO_port)&0xDF;
    data_rw8 |= 0x20;
```



Custom Embedded Solutions

```
    outportb(GPIO_port, data_rw8);
}
else if(strcmp(argv[1], "-l5") == 0){
    printf("GPO5 -> Low\n");
    Output_mode();
    data_rw8 = inportb(GPIO_port)&0xDF;
    outportb(GPIO_port, data_rw8);
}

else if(strcmp(argv[1], "-h6") == 0){
    printf("GPO6 -> High\n");
    Output_mode();
    data_rw8 = inportb(GPIO_port)&0xBF;
    data_rw8 |= 0x40;
    outportb(GPIO_port, data_rw8);
}
else if(strcmp(argv[1], "-l6") == 0){
    printf("GPO6 -> Low\n");
    Output_mode();
    data_rw8 = inportb(GPIO_port)&0xBF;
    outportb(GPIO_port, data_rw8);
}

else if(strcmp(argv[1], "-h7") == 0){
    printf("GPO7 -> High\n");
    Output_mode();
    data_rw8 = inportb(GPIO_port)&0x7F;
    data_rw8 |= 0x80;
    outportb(GPIO_port, data_rw8);
}
else if(strcmp(argv[1], "-l7") == 0){
    printf("GPO7 -> Low\n");
    Output_mode();
    data_rw8 = inportb(GPIO_port)&0x7F;
    outportb(GPIO_port, data_rw8);
}

else{
```



```
        help();
        return;
    }

    return;
}

void Enter_sio_config()                //Enter F81865 Configuration
{
    outportb(index_port, 0x87);
    delay(1);                          //Delay some time
    outportb(index_port, 0x87);
    outportb(index_port, 0x07);        //Super IO Selct Bank Register Number
    outportb(data_port , 0x03);       //Select logical device 7
    outportb(index_port, 0x30);
    outportb(data_port , 0x01);
}

void Exit_sio_config()                //Exit F81865 Configuration
{
    outportb(index_port, 0xAA);
}

void ENABLE_GPIO()
{
    int BusNum   = 0x00; //bus0
    int DevFunc  = 0xA3; //device20, function3
    int RegNum   = 0x44; //reg44
    long int data_rw32;

    data_rw32 = (BusNum << 8) + (DevFunc << 8);
    data_rw32 += (RegNum & 0xFC);
    data_rw32 |= 0x80000000;
    outportl(0xCF8, data_rw32);
    outportb(0xCFC, 0xC1);
}

void Input_mode()
```



```
{
    Enter_sio_config();
    outportb(index_port, 0xF0);
    outportb(data_port, 0x41);
    Exit_sio_config();
}

void Output_mode()
{
    Enter_sio_config();
    outportb(index_port, 0xF0);
    outportb(data_port, 0x40);
    Exit_sio_config();
}

void help()
{
    printf("WIN ENTERPRISES GPIO Program\n");
    printf("Usage: GPIO -i (Show GPI Settings)\n");
    printf("Usage: GPIO -hx (Set GPO Value to high)\n");
    printf("           x = 0 ~ 7\n");
    printf("Usage: GPIO -lx (Set GPO Value to low)\n");
    printf("           x = 0 ~ 7\n");
}
```

3.2 Watchdog timer Sample Program for DOS environment

```
#include <stdio.h>
#include <string.h>
#include <dos.h>
#include <stdlib.h>
#include <inlines/pc.h>

#define index_port 0x2E           //Super IO Index port address
#define data_port  0x2F         //Super IO Data port address

void Enter_sio_config();
void Exit_sio_config();
void help();

int main(int argc, char *argv[])
{
    int data_rw8;

    if (argc<2){
        help();
        return;
    }

    if(strcmp(argv[1], "-s") == 0){
        //Show Watchdog Register Settings
        Enter_sio_config();
        outportb(index_port, 0xF5);
        data_rw8 = inportb(data_port)&0x08;
        if(data_rw8 == 0x00){
            //second mode
            outportb(index_port, 0xF6);
            data_rw8 = inportb(data_port);
            printf("Second mode: %d second\n", data_rw8);
        }
    }
    else{
        //minute mode
```



Custom Embedded Solutions

```
    outportb(index_port, 0xF6);
    data_rw8 = inportb(data_port);
    printf("Minute mode: %d minute\n", data_rw8);
}
}
else if(strcmp(argv[1], "-t") == 0 ){
    //Set Time-out Value
    if(argv[2] == NULL){
        help();
        return;
    }
    else{
        Enter_sio_config();
        outportb(index_port, 0xFA);
        data_rw8 = inportb(data_port)|0x01;
        outportb(data_port, data_rw8);

        outportb(index_port, 0xF5);
        data_rw8 = inportb(data_port)&0xF7|0x31;
        outportb(data_port, data_rw8);
        sscanf(argv[2], "%d", &data_rw8);
        outportb(index_port, 0xF6);
        outportb(data_port, data_rw8);
        printf("Watchdog Timer will count down for %d second(s)\n", data_rw8);
    }
}
else if(strcmp(argv[1], "-m") == 0 ){
    //Set Time-out Value
    if(argv[2] == NULL){
        help();
        return;
    }
    else{
        Enter_sio_config();
        outportb(index_port, 0xFA);
        data_rw8 = inportb(data_port)|0x01;
        outportb(data_port, data_rw8);
```



Custom Embedded Solutions

```
    outportb(index_port, 0xF5);
    data_rw8 = inportb(data_port)&0xF7|0x31;
    data_rw8 |= 0x08;
    outportb(data_port, data_rw8);
        sscanf(argv[2], "%d", &data_rw8);
    outportb(index_port, 0xF6);
    outportb(data_port, data_rw8);
        printf("Watchdog Timer will count down for %d minute(s)\n", data_rw8);
    }
}
Exit_sio_config();
return;
}

void Enter_sio_config()                //Enter F81865 Configuration
{
    outportb(index_port, 0x87);
    delay(1);                          //Delay some time
    outportb(index_port, 0x87);
    outportb(index_port, 0x07);         //Super IO Selct Bank Register Number
    outportb(data_port , 0x07);        //Select logical device 7
    outportb(index_port, 0x30);
    outportb(data_port , 0x01);
}

void Exit_sio_config()                //Exit F81865 Configuration
{
    outportb(index_port, 0xAA);
}

void help()
{
    printf("WIN ENTERPRISES Watchdog Timer Program\n");
    printf("Usage: WDT -s      (Show Watchdog Register Settings)\n");
    printf("Usage: WDT -t xxx (Set Time-out Value)\n");
    printf("                xxx = 1 ~ 255 seconds\n");
    printf("                xxx = 0 : Time-out Disable \n");
    printf("Usage: WDT -m xxx (Set Time-out Value)\n");
}
```



Custom Embedded Solutions

```
printf("          xxx = 1 ~ 255 minutes\n");  
printf("          xxx = 0 : Time-out Disable \n");  
}
```

