

# MB-73240 Embedded Board

PC/104+ module with Intel © Atom™ 1.8GHz D525, LVDS, 2 LAN, SATA, CFast

## User's Manual

Version 1.0



[sales@win-ent.com](mailto:sales@win-ent.com) +1 (978) 688-2000

**© Copyright 2012. All Rights Reserved  
Manual Edition 1.0, March, 2012**

This document contains proprietary information protected by copyright. All rights are reserved; no part of this manual may be reproduced, copied, translated or transmitted in any form or by any means without prior written permission of the manufacturer.

The content of this document is intended to be accurate and reliable; the original manufacturer assumes no responsibility for any inaccuracies that may be contained in this manual. The original manufacturer reserves the right to make improvements to the products described in this manual at any time without prior notice.

## **Trademarks**

IBM, EGA, VGA, XT/AT, OS/2 and PS/2 are registered trademarks of International business Machine Corporation

Award is a trademark of Award Software International, Inc

Intel is a trademark of Intel

RTL is a trademark of Realtek

VIA is a trademark of VIA Technologies, Inc

Microsoft, Windows, Windows NT and MS-DOS are either trademarks or registered trademarks of Microsoft Corporation

All other product names mentioned herein are used for identification purpose only and may be trademarks and/or registered trademarks of their respective companies

## **Limitation of Liability**

While reasonable efforts have been made to ensure the accuracy of this document, the manufacturer and distributor assume no liability resulting from errors or omissions in this document, or from the use of the information contained herein.

For more information on MB-73240 or other WIN Enterprises products, please visit our website <http://www.win-ent.com>.

For technical support please send your inquiry to [consultants@win-ent.com](mailto:consultants@win-ent.com)

## Table of Contents

Safety information .....	5
<i>Electrical safety</i> .....	5
<i>Operation safety</i> .....	5
<i>Statement</i> .....	6
<i>Packing list</i> .....	6
Chapter 1 Product Information.....	7
1.1 <i>Block Diagram</i> .....	7
1.2 <i>Key Features</i> .....	8
1.3 <i>Board Placement</i> .....	10
Chapter 2 Jumpers and Connectors.....	12
2.1 <i>Connector</i> .....	12
CN1: VGA Connector (Pin Header) .....	12
CN2: LVDS CONNECTOR .....	13
CN3: AT POWER CONNECTOR.....	13
CN4: AUX POWER CONNECOTR .....	13
CN5: Flat Panel Inverter Connector .....	13
CN6: ATX POWER CONNECOTR .....	13
CN7: PC/104 Plus Connector .....	14
CN8: Auxiliary Power Connector .....	14
CN9: Power LED /HDD LED/Reset/Speak Out Connector .....	15
CN10: ATX Power Control Connector .....	15
CN12: FAN Connector .....	15
CN13 GPIO Connector .....	15
CN14, CN15: USB1/2, USB3/4 Connector (Pin Header) .....	16
CN16: COM2 –RS422/RS485 Connector (Pin Header).....	16
CN18: CN17: COM1, COM2 RS-232 Pin-Header .....	16
CN19: LAN1, LAN2 Interface.....	16
CN20: SATA connector .....	17
CN21: Audio Interface.....	17
CN22: CFAST .....	17
CN23: PC/104 Connector .....	18
2.2 Jumper setting.....	19
Chapter 3 BIOS Setup .....	20
3.1 <i>Entering the CMOS Setup Program</i> .....	20
3.2 <i>Menu Options</i> .....	22
3.3 <i>Advanced Menu</i> .....	23

# User's Manual

---

3.3.1 CPU Configuration.....	24
3.3.2 IDE Configuration .....	25
3.3.3 Super IO Configuration .....	26
3.3.4 Hardware Health Configuration .....	27
3.3.5 ACPI Configuration .....	28
3.3.6 AHCI Configuration .....	32
3.3.7 ISA Configuration.....	34
3.3.8 USB Configuration .....	36
3.4 PCIPnP Menu .....	37
3.5 Boot Menu.....	39
3.5.1 Boot Settings Configuration.....	40
3.6 Security Menu.....	41
3.7 Chipset Menu.....	43
3.7.1 North Bridge Configuration .....	44
3.7.2 South Bridge Configuration .....	46
3.8 Exit.....	47

## Safety information

### Electrical safety

- To prevent electrical shock hazard disconnect the power cable from the electrical outlet before relocating the system.
- When adding or removing devices to or from the system ensure that the power cables for the devices are unplugged before the signal cables are connected. If possible, disconnect all power cables from the existing system before you add a device.
- Before connecting or removing signal cables from the motherboard make sure that all the power cables are unplugged.
- Seek professional assistance before using an adapter or extension cord. These devices could interfere with the grounding circuit.
- Make sure that your power supply is set to the correct voltage in your area.
- If you are not sure about the voltage of the electrical outlet you are using contact your local power company.
- If the power supply is broken do not try to fix it by yourself. Contact a qualified service technician or your retailer.

### Operational safety

- Before installing the motherboard and adding devices carefully read all the manuals that came with the package.
- Before using the product make sure all cables are correctly connected and the power cables are not damaged. If you detect any damage contact your dealer immediately.
- To avoid short circuits keep paper clips, screws, and staples away from connectors, slots, sockets and circuitry.
- Avoid dust, humidity, and temperature extremes. Do not place the product in an area where it may become wet.
- Deploy the product on a stable surface.
- If you encounter technical problems with the product contact a qualified service technician or your retailer.

## Statement

- All rights reserved. No part of this publication may be reproduced in any form or by any means, without prior written permission from the publisher.
- All trademarks are the properties of the respective owners.
- All product specifications are subject to change without prior notice

## Packing list

- 1 x MB-73240
- 1 x CD (Driver & User's Manual)
- 1 x Dual RJ-45 connector adaptor card (optional)
- 1 x Cable Kit (optional)
  - 1 x ATX power cable
  - 1 x RS-232 cable
  - 1 x VGA cable
  - 1 x USB cable

## Chapter 1. Product Information

### 1.1 Block Diagram

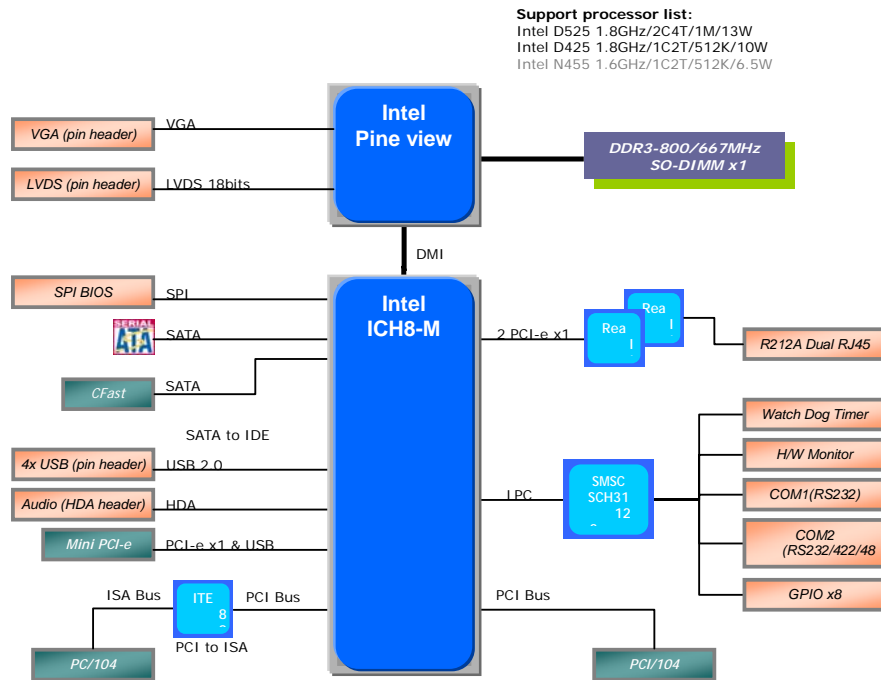

## 1.2 Key Features

### ■ Features:

- Supports powerful dual-core Intel® Atom™ D525 processors
- Dual 10/100/1000Mbps ethernet
- Supports One cFast, Two serial ports and four USB 2.0 ports
- One DDR3 SO-DIMM socket supports up to 2GB memory
- Supports SM bus w/ Alert

### ■ System

CPU	Intel® Atom D525, D425
BIOS	AMI® SPI BIOS
System Chipset	Intel® ICH8M
System Memory	1 x DDR3 SO-DIMM socket supports 667/800MHz memory max. up to 2GB w/o ECC registered
SSD	1 x CFast
Watchdog Timer	255 levels timer interval, (1sec. to 255min.), setup by software.
Expansion Interface	1 x PCI104, 1 x PC104
Battery	Lithium 3V/220mAH

### ■ I/O

I/O Interface	1 x SATA, 1 x RS-232, 1 x RS-232/422/485
USB	4 x USB 2.0
Audio	High definition audio interface
GPIO	Onboard programmable 8-bit Digital I/Os

### ■ Ethernet

Speed	10/100/1000Mbps
Interface	2 x RJ-45
Ethernet Interface	IEEE 802.3 10/100/1000 Mbps compliant physical layer

### ■ Display

Chipset	Intel® Pineview-D processor Integrated
Memory Size	TBD
Resolution	VGA: 2048 x 1536
LCD/LVDS Interface	LVDS: 1366 x 768 18-bit LVDS
Dual Simultaneous Displays	VGA + LVDS

### ■ Mechanical and Environment

Dimension ( L x W )	96mm (L) x 116mm (W) (3.8" L x 4.6" W) PC/104+ Form Factor
Operating Temperature	0°C ~ 60°C ( 32°F ~ 140°F )
Operating Humidity	10% ~ 85% relative humidity, non-condensing
Storage Temperature	-20°C ~ 85°C ( -4°F ~ 185°F )
Storage Humidity	10% ~ 85% relative humidity, non-condensing



# User's Manual

## ■ Power

Power Supply Voltage	+5V DC in
Power Consumption	TBD

## ■ Packing List

<ul style="list-style-type: none"><li>• 1 x MB-73240 SBC</li><li>• 1 x CD (Manual, Quick installation guide, Utility driver)</li></ul>
--

## ■ Ordering Information

Standard	
MB-7324A	PC/104+ module with Intel Atom 1.8GHz D525, LVDS, 2 LAN, SATA, CFast
MB-7324B	PC/104+ module with Intel Atom 1.8GHz D425, LVDS, 2 LAN, SATA, CFast
MB-7324C	PC/104+ module with Intel Atom 1.8GHz D525, LVDS, 2 LAN, SATA, CFast (pin down)
MB-7324D	PC/104+ module with Intel Atom 1.8GHz D425, LVDS, 2 LAN, SATA, CFast (pin down)

All specifications and photos are subject to change without notice\*

## 1.3 Board Placement

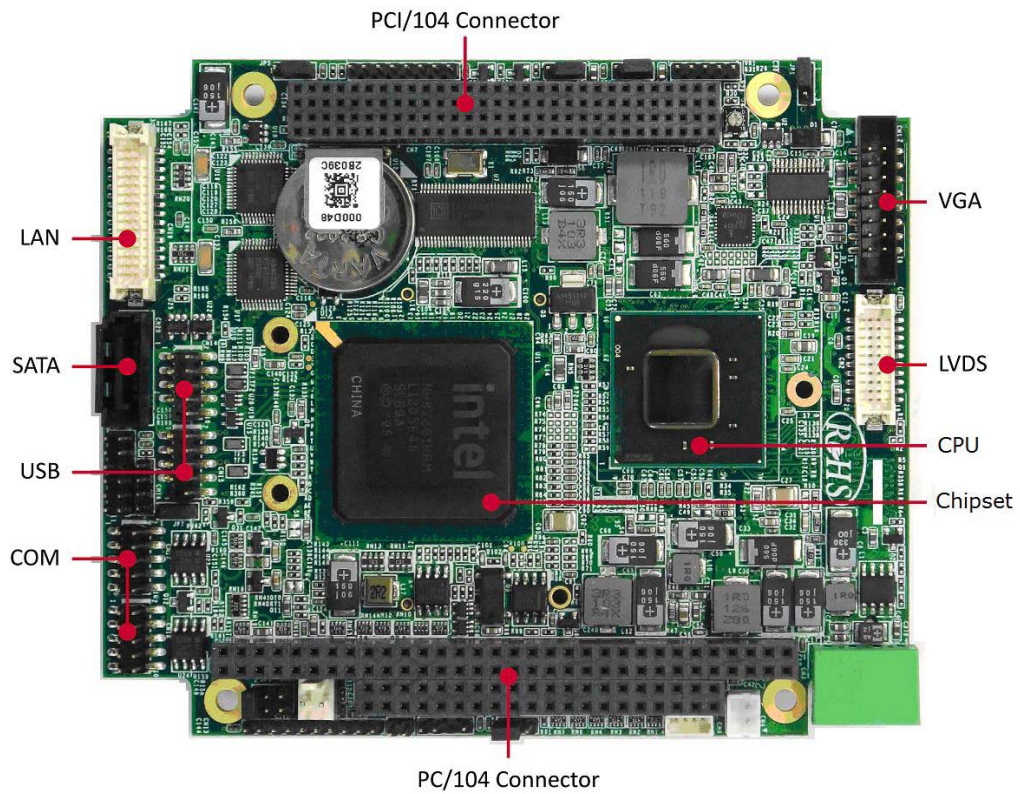

# User's Manual

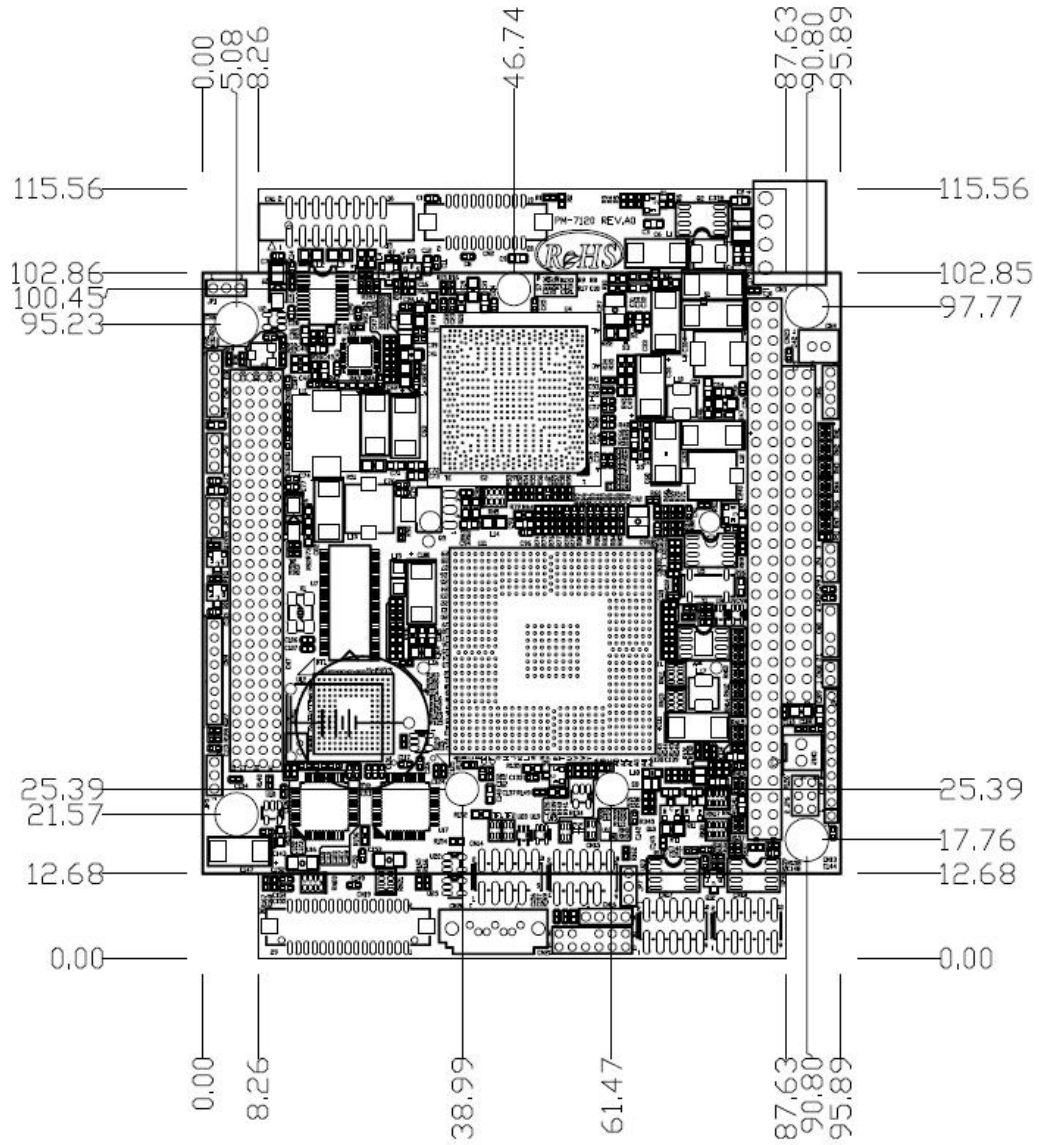

## Chapter 2. Jumpers and Connectors

### 2.1 Connector

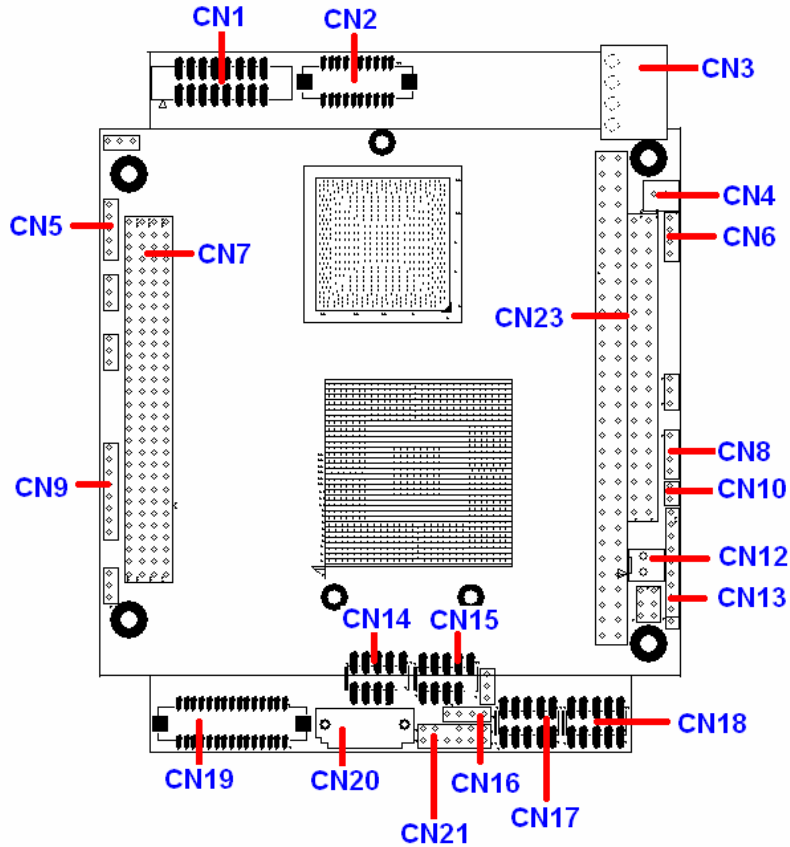

**CN1: VGA Connector (Pin Header)**

Pin	Signal	Pin	Signal
1	RED	2	GREEN
3	BLUE	4	+5V
5	GND	6	GND
7	GND	8	GND
9	+5V	10	GND
11	+5V	12	DDC Data
13	H-SYNC	14	V-SYNC
15	DDC Clock	16	NC

## CN2: LVDS CONNECTOR

Pin	Define	Pin	Define
1	LVDS_D0+	2	LVDS_D0-
3	GND	4	GND
5	LVDS_D1+	6	LVDS_D1-
7	GND	8	PANEL POWER
9	LVDS_D2+	10	LVDS_D2-
11	LVDS_CLK+	12	LVDS_CLK-
13	GND	14	GND
15	NC	16	NC
17	LVDS_BKTEN	18	PANEL POWER
19	LVDS_SDA	20	LVDS_SCL

## CN3: AT POWER CONNECTOR

Pin	Define	Pin	Define
1	+5V	2	+5V
3	GND	4	GND

## CN4: AUX POWER CONNECTOR

Pin	Define	Pin	Define
1	GND	2	+12V

## CN5: Flat Panel Inverter Connector

Pin	Assignment
1	+12V
2	GND
3	FPBKLEN
4	VR
5	+5V

## CN6: ATX POWER CONNECTOR

Pin	Define	Pin	Define
1	+5Vstby	2	+5Vstby
3	GND		PSON#

## CN7: PC/104 Plus Connector

Signal	Pin	Signal	Pin	Signal	Pin	Signal	Pin	D30	C30	B30	A30
GND	A1	NC	B1	+5V	C1	AD00	D1				
VIO	A2	AD02	B2	AD01	C2	+5V	D2				
AD05	A3	GND	B3	AD04	C3	AD03	D3				
C/BE0#	A4	AD07	B4	GND	C4	AD06	D4				
GND	A5	AD09	B5	AD08	C5	GND	D5				
AD11	A6	VIO	B6	AD10	C6	M66EN	D6				
AD14	A7	AD13	B7	GND	C7	AD12	D7				
+3.3V	A8	C/BE1#	B8	AD15	C8	+3.3V	D8				
SERR#	A9	GND	B9	SBO#	C9	PAR	D9				
GND	A10	PERR#	B10	+3.3V	C10	SDONE	D10				
STOP#	A11	+3.3V	B11	LOCK#	C11	GND	D11				
+3.3V	A12	TRDY#	B12	GND	C12	DEVSEL#	D12				
FRAME#	A13	GND	B13	IRDY#	C13	+3.3V	D13				
GND	A14	AD16	B14	+3.3V	C14	C/BE2#	D14				
AD18	A15	+3.3V	B15	AD17	C15	GND	D15				
AD21	A16	AD20	B16	GND	C16	AD19	D16				
+3.3V	A17	AD23	B17	AD22	C17	+3.3V	D17				
IDSEL0	A18	GND	B18	IDSEL1	C18	IDSEL2	D18				
AD24	A19	C/BE3#	B19	VIO	C19	IDSEL3	D19				
GND	A20	AD26	B20	AD25	C20	GND	D20				
AD29	A21	+5V	B21	AD28	C21	AD27	D21				
+5V	A22	AD30	B22	GND	C22	AD31	D22				
REQ0#	A23	GND	B23	REQ1#	C23	VIO	D23				
GND	A24	REQ2#	B24	+5V	C24	GNT0#	D24				
GNT1#	A25	VIO	B25	GNT2#	C25	GND	D25				
+5V	A26	CLK0	B26	GND	C26	CLK1	D26				
CLK2	A27	+5V	B27	CLK3	C27	GND	D27				
Ground	A28	INTD#	B28	+5V	C28	RST#	D28				
+12V	A29	INTA#	B29	INTB#	C29	INTC#	D29				
-12V	A30	REQ3#	B30	GNT3#	C30	GND	D30				

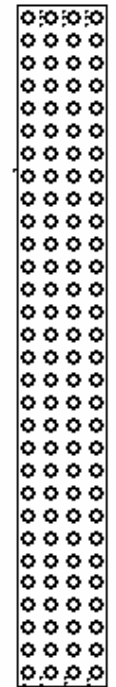

D30 C30 B30 A30

D1 C1 B1 A1

## CN8: Auxiliary Power Connector

Pin	Assignment		
1	-5V		<b>4</b>
2	GND		
3	Key pin		
4	-12V		<b>1</b>

## CN9: Power LED /HDD LED/Reset/Speak Out Connector

Pin	Assignment
1	Power LED+
2	Power LED-
3	HDD LED+
4	HDD LED-
5	Reset +
6	Reset -
7	Speak Out+
8	Speak Out-

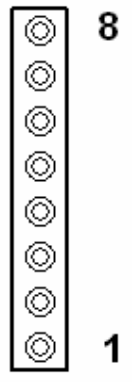

## CN10: ATX Power Control Connector

Pin	Assignment
1	PANSW-
2	PANSW+

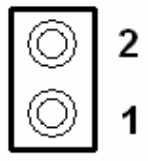

## CN12: FAN Connector

Pin	Define	Pin	Define
1	+5V	2	GND

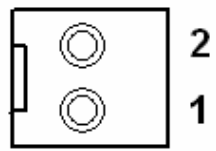

## CN13 GPIO Connector

Pin	Assignment
1	+3.3V
2	GPIO0
3	GPIO1
4	GPIO2
5	GPIO3
6	GPIO4
7	GPIO5
8	GPIO6
9	GPIO7
10	GND



# User's Manual

## CN14, CN15: USB1/2, USB3/4 Connector (Pin Header)

Pin	Assignment	Pin	Assignment
1	+5V	2	+5V
3	Data0-	4	Data1-
5	Data0+	6	Data1+
7	GND	8	GND
9	Key Pin	10	GND

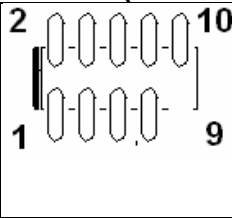

## CN16: COM2 –RS422/RS485 Connector (Pin Header)

Pin	Assignment
1	485RXD-
2	485RXD+
3	485TXD+
4	485TXD-

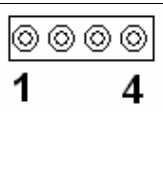

## CN18: CN17: COM1, COM2 RS-232 Pin-Header

Pin	Assignment	Pin	Assignment
1	DCD	2	DSR
2	RXD	4	RTS
3	TXD	6	CTS
4	DTR	8	RI
5	GND	10	NC

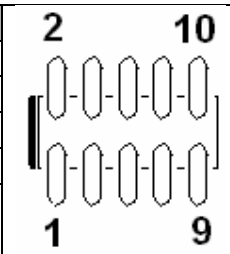

## CN19: LAN1, LAN2 Interface

Pin	Signal	Pin	Signal
1	LAN1-D2+	2	LAN1-D0+
3	LAN1-D2-	4	LAN1-D0-
5	LAN1-D3+	6	LAN1-D1+
7	LAN1-D3-	8	LAN1-D1-
9	+3.3V	10	GND
11	LAN1-ACT	12	LAN1-LINK
13	LAN1_LINK100	14	LAN1-LINK1000
15	GND	16	GND
17	LAN2-D0+	18	LAN2-D2+
19	LAN2-D0-	20	LAN2-D2-
21	LAN2-D1+	22	LAN2-D3+
23	LAN2-D1-	24	LAN2-D3-
25	LAN2-ACT	26	LAN2-LINK
27	LAN2_LINK100	28	LAN2-LINK1000
29	GND	30	GND

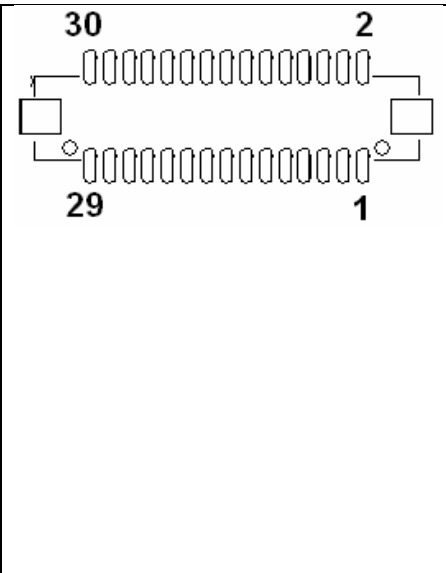



## CN20: SATA connector

Pin	Signal Name
1	GND
2	TX+
3	TX-
4	GND
5	RX-
6	RX+
7	GND

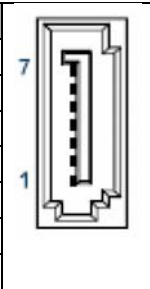

## CN21: Audio Interface

Pin	Assignment	Pin	Assignment
1	+5V	2	GND
3	GND	4	CLKBIT
5	+3.3V	6	Key Pin
7	SDTAIN	8	SYNC
9	GND	10	PRST#
11	SDATAOUT	12	NC

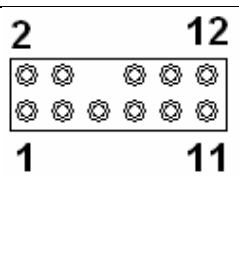

## CN22: CFAST

Signal segment		Power segment	
Pin	Name	Pin	Name
S1	GND	PC1	CDI
S2	A+	PC2	GND
S3	A-	PC3	TBD
S4	GND	PC4	TBD
S5	B-	PC5	TBD
S6	B+	PC6	TBD
S7	GND	PC7	GND
		PC8*	LED1
		PC9*	LED2
		PC10	IO1
		PC11	IO2
		PC12	IO3
		PC13	PWR
		PC14	PWR
		PC15	PGND
		PC16	PGND
		PC17	CDO

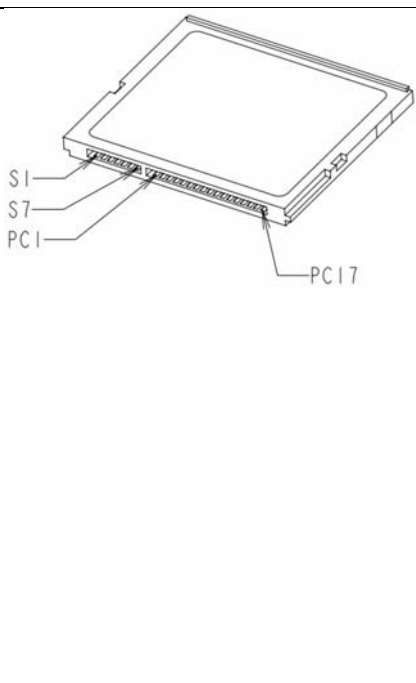

\*Refer above for LED output design guide

# User's Manual

## CN23: PC/104 Connector

Signal	Pin	Signal	Pin	Signal	Pin	Signal	Pin
GND	C0	GND	D0	IOCHCHK	A1	GND	B1
SBHE*	C1	MEMCS16*	D1	SD7	A2	RESET	B2
LA23	C2	IOSC16*	D2	SD6	A3	+5V	B3
LA22	C3	IRQ10	D3	SD5	A4	IRQ9	B4
LA21	C4	IRQ11	D4	SD4	A5	-5V	B5
LA20	C5	IRQ12	D5	SD3	A6	NC	B6
LA19	C6	IRQ15	D6	SD2	A7	-12V	B7
LA18	C7	IRQ14	D7	SD1	A8	0 wait state	B8
LA17	C8	NC	D8	SD0	A9	+12V	B9
MEMR*	C9	NC	D9	IOCHRDY	A10	NC	B10
MEMW*	C10	NC	D10	AEN	A11	SMEMW#	B11
SD8	C11	NC	D11	SA19	A12	SMEMR*	B12
SD9	C12	NC	D12	SA18	A13	IOW*	B13
SD10	C13	NC	D13	SA17	A14	IOR*	B14
SD11	C14	NC	D14	SA16	A15	NC	B15
SD12	C15	NC	D15	SA15	A16	NC	B16
SD13	C16	+5V	D16	SA14	A17	NC	B17
SD14	C17	MASTER*	D17	SA13	A18	NC	B18
SD15	C18	GND	D18	SA12	A19	REFRESH*	B19
NC	C19	GND	D19	SA11	A20	SYSCLK	B20
				SA10	A21	IRQ7	B21
				SA9	A22	IRQ6	B22
				SA8	A23	IRQ5	B23
				SA7	A24	IRQ4	B24
				SA6	A25	IRQ3	B25
				SA5	A26	NC	B26
				SA4	A27	TC	B27
				SA3	A28	BALE	B28
				SA2	A29	+5V	B29
				SA1	A30	OSC	B30
				SA0	A31	GND	B31
				GND	A32	GND	B32

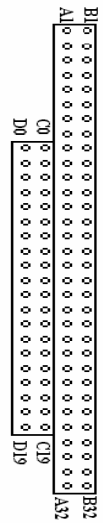

## 2.2 Jump setting

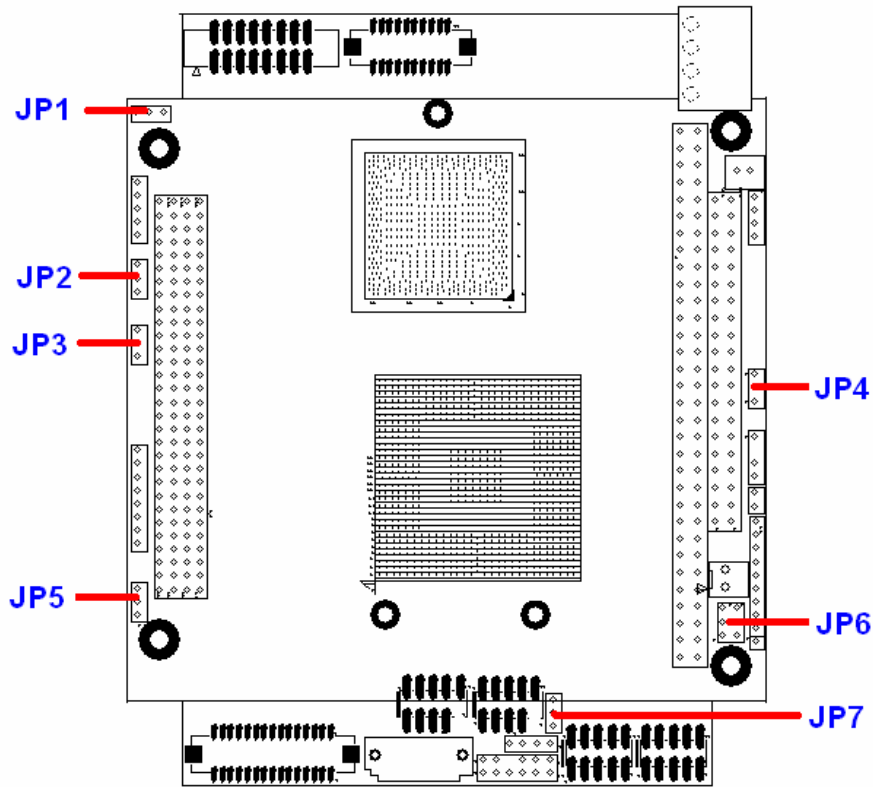

JP1	LCD Power Select. (1-2: +3.3V ; 2-3: +5V)
JP2	PCI VIO Voltage Select (1-2: +5V ; 2-3: +3.3V)
JP3	WDT Function Select. (1-2: IRQ11 ; 2-3: Reset)
JP4	Clear CMOS (1-2: Hold CMOS; 2-3: Clear CMOS)
JP5	AT & ATX MODE SELECT (1-2:AT MODE ; 2-3: ATX MODE)
JP6	COM2 MODE SELECT (1-2: RS232 ; 3-4: RS485 4-Wire ; 5-6: RS485 2-Wire)
JP7	PSON# Signal Souce Select. (1-2: ICH8M ; 2-3: SIO)

## Chapter 3. BIOS Setup

### 3.1 Entering the CMOS Setup Program

Use the CMOS Setup program to modify the system parameters to reflect the options installed in your system and to customize your system. For example, you should run the Setup program after you:

1. Received an error code at startup
2. Install another disk drive
3. Use your system after not having used it for a long time
4. Find the original setup missing
5. Replace the battery
6. Change to a different type of CPU
7. Run the Flash program to update the system BIOS

Run the CMOS Setup program after you turn on the system. On-screen instructions explain how to use the program.

↓ Enter the CMOS Setup program's main menu as follows:

1. Turn on or reboot the system. After the BIOS performs a series of diagnostic checks, the following message appears:  
"Press DEL to enter SETUP"
2. Press the <DEL> key to enter CMOS Setup program. The main menu appears:

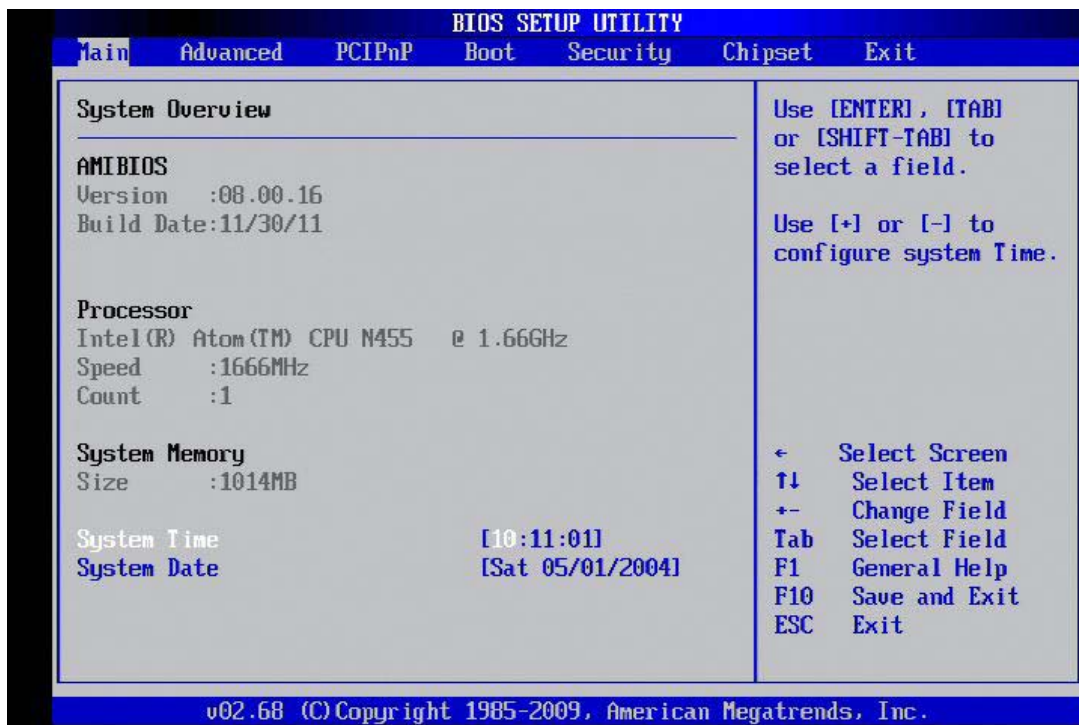

3. Choose a setup option with the arrow keys and press <Enter>. See the following sections for a brief description of each setup option.

## User's Manual

---

**AMIBIOS:** Displays the auto-detected BIOS information.

**Processor:** Displays the auto-detected CPU specification.

**System Memory:** Displays the auto-detected system memory.

**SystemTime: [hour:min:sec]**

This item allows you to set the system time.

**System Date: [Day mm/dd/yyyy]**

This item allows you to set the system date.

In the main menu, press F10 ("Save Changes and Exit") to save your changes and reboot the system. Choosing "Discard Changes and Exit" ignores your changes and exits the program. Pressing <ESC> anywhere in the program returns you to the main menu.

## 3.2 Menu Options

The main menu options of the CMOS Setup program are described in the following and the following sections of this chapter.

**Main:** For changing the basic system configurations.

**Advanced:** For changing the advanced system settings.

**PCIPnP:** For changing the advanced PCI/PnP Settings.

**Boot:** For changing the system boot configurations.

**Security:** Use this menu to set User and Supervisor Passwords.

**Chipset:** For changing the chipset settings.

**Exit:** For selecting the exit options and loading default settings.

## 3.3 Advanced Menu

The Advanced menu items allow you to change the settings for the CPU and other system devices.

↓ Use the **Advanced Setup** option as follows:

1. Choose "Advanced" from the main menu. The following screen appears:

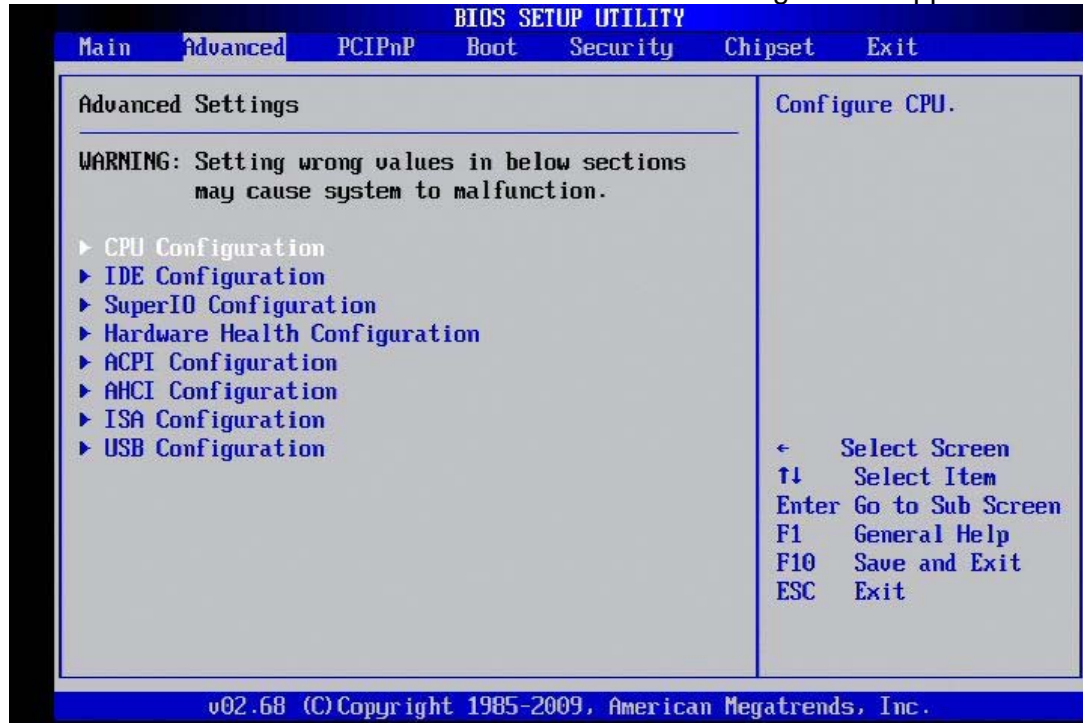

2. Use the arrow keys to move between fields. Modify the selected field using the PgUP/PgDN/+/- keys. Some fields let you enter numeric values directly.
3. After you have finished with the Advanced setup, press the <ESC> key to return to the main menu.

# User's Manual

## 3.3.1 CPU Configuration

This sub menu shows the CPU-related information which is automatically detected by BIOS.

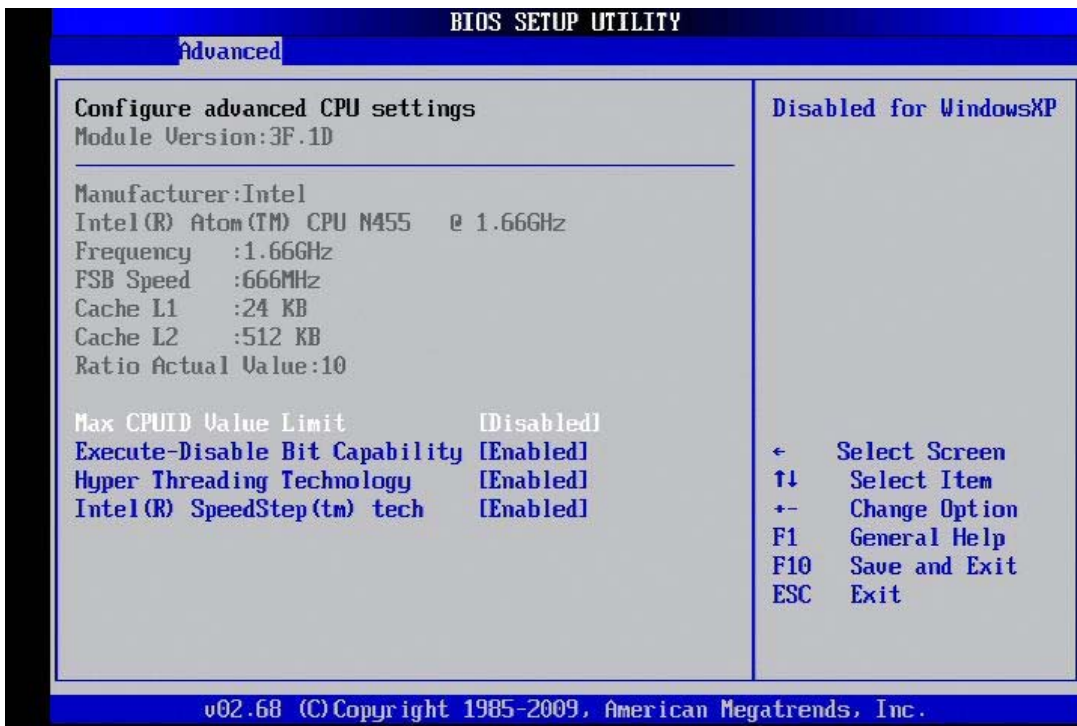



## 3.3.2 IDE Configuration

This sub menu allows you to set or change the configurations for the IDE devices installed in the system.



### Primary \* IDE Master

This information is auto-detected by BIOS and is not user-configurable. It will show "Not Detected" if no IDE device is installed in the system.

### Primary IDE Slave

This information is auto-detected by BIOS and is not user-configurable. It will show "Not Detected" if no IDE device is installed in the system.

## 3.3.3 Super IO Configuration

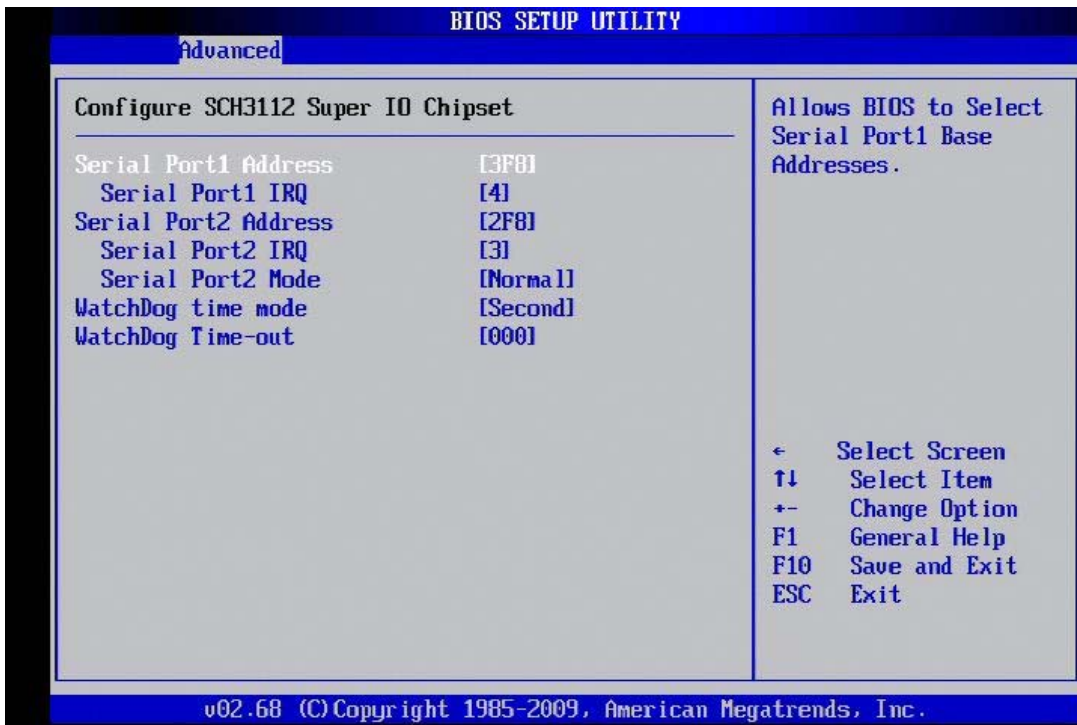

### **Serial Port1 Address: [3F8/IRQ4]**

Selects the Serial Port1 base address and IRQ.

### **Serial Port2 Address: [2F8/IRQ3]**

Selects the Serial Port2 base address and IRQ.

### **Serial Port2 Mode: [Normal]**

Selects the Serial Port mode.

# User's Manual

## 3.3.4 Hardware Health Configuration

This screen shows you the CPU core voltage, System voltage, System temperature.

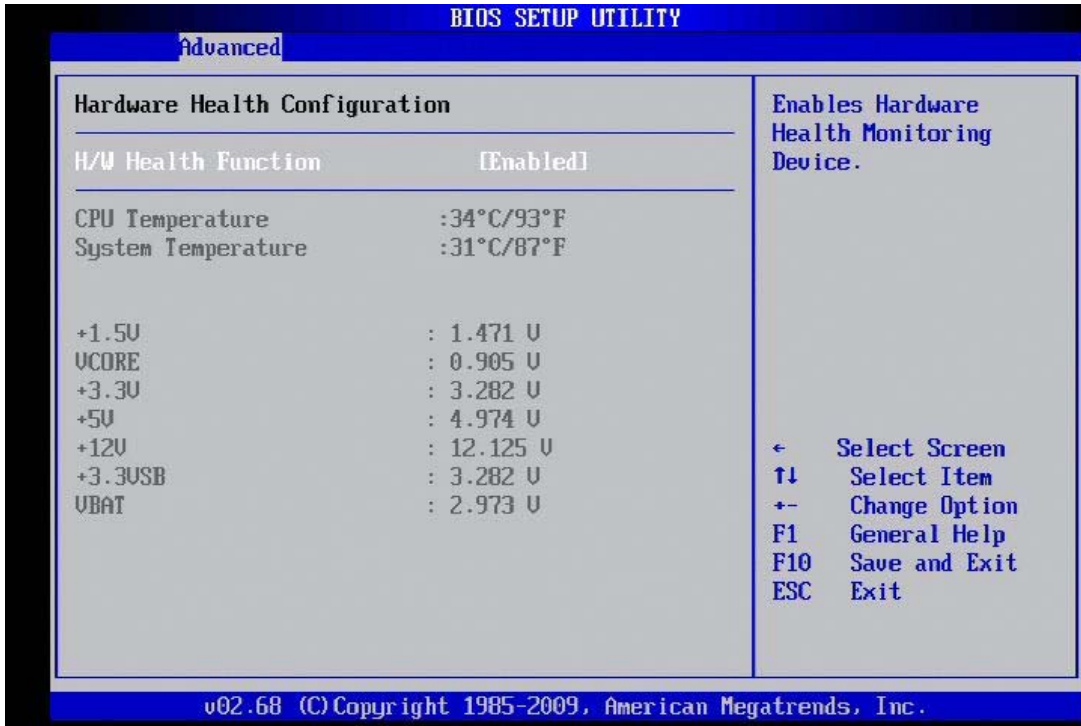

## 3.3.5 ACPI Configuration

This sub menu is used to change the settings for the ACPI.

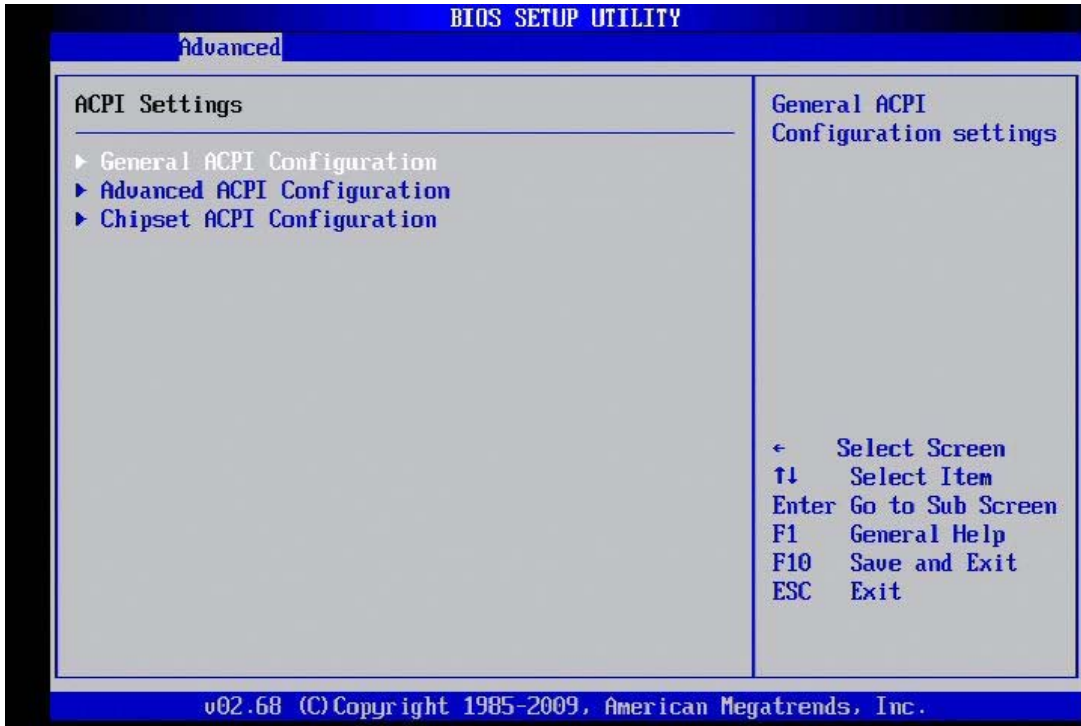

# User's Manual

## General ACPI Configuration

This sub menu is used to change the General ACPI Configuration for the ACPI.

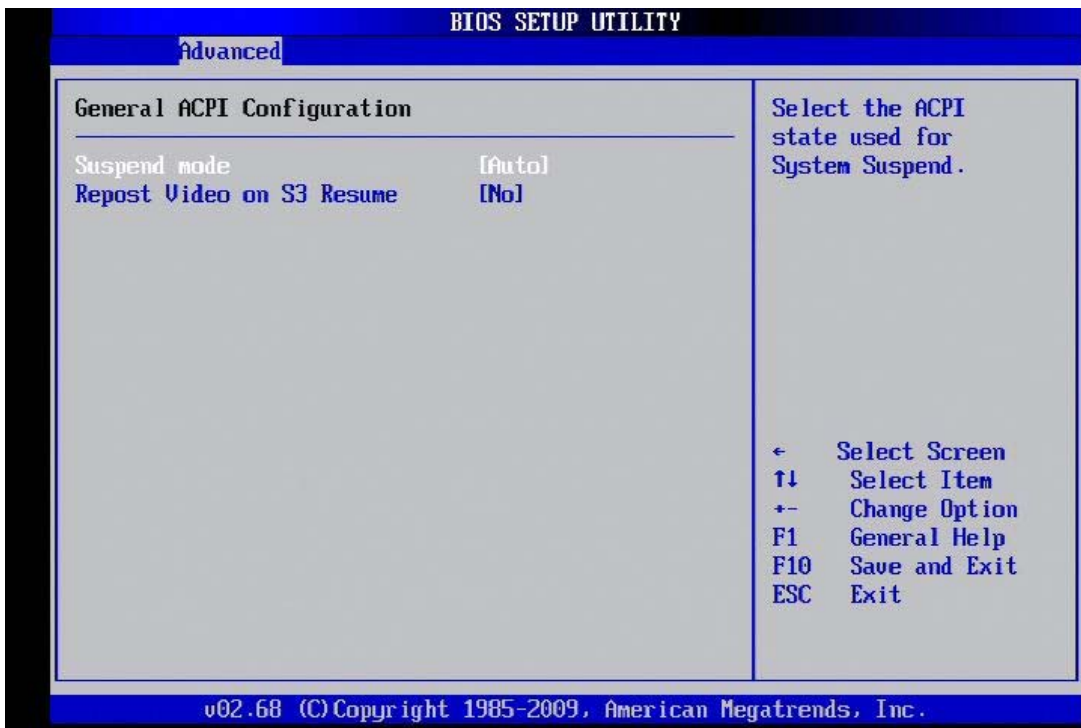

# User's Manual

## Advanced ACPI Configuration

This sub menu configures additional ACPI options. It contains below sub-menus

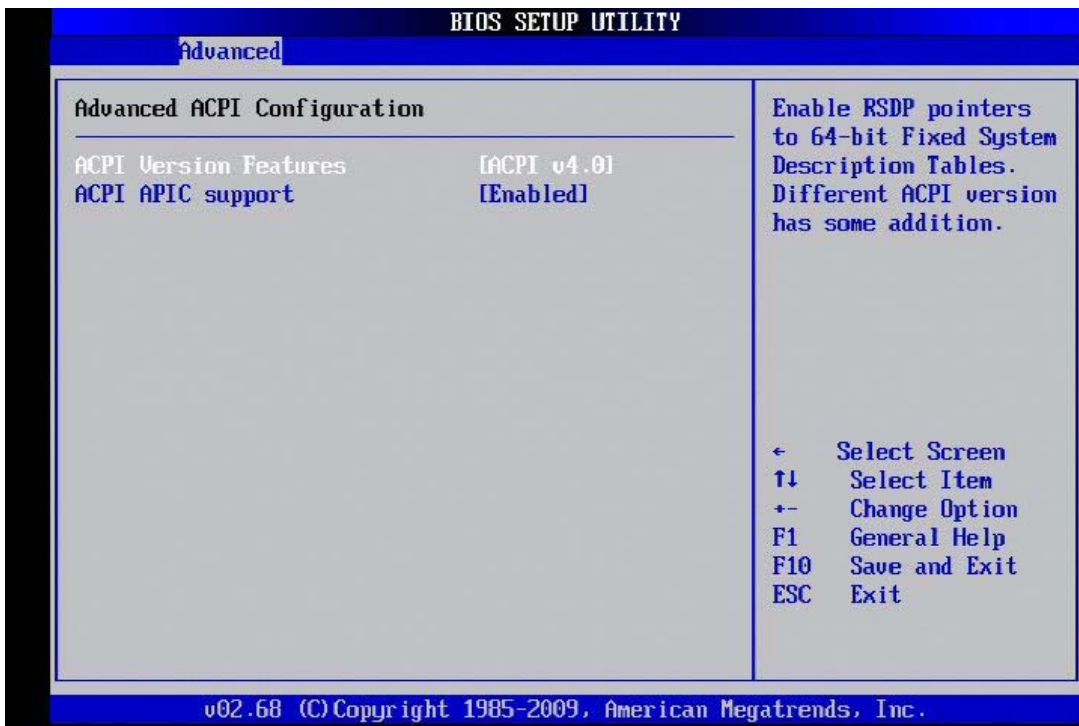

### ACPI Version Features: [ACPI v4.0]

This item allows you to enable or disable RSPD pointers to 64-bit Fixed System Description Tables.

### ACPI APIC support: [Enabled]

This item allows you to enable or disable APIC features.

# User's Manual

## South Bridge ACPI Configuration

This sub menu is used to change the bridge settings for the ACPI.

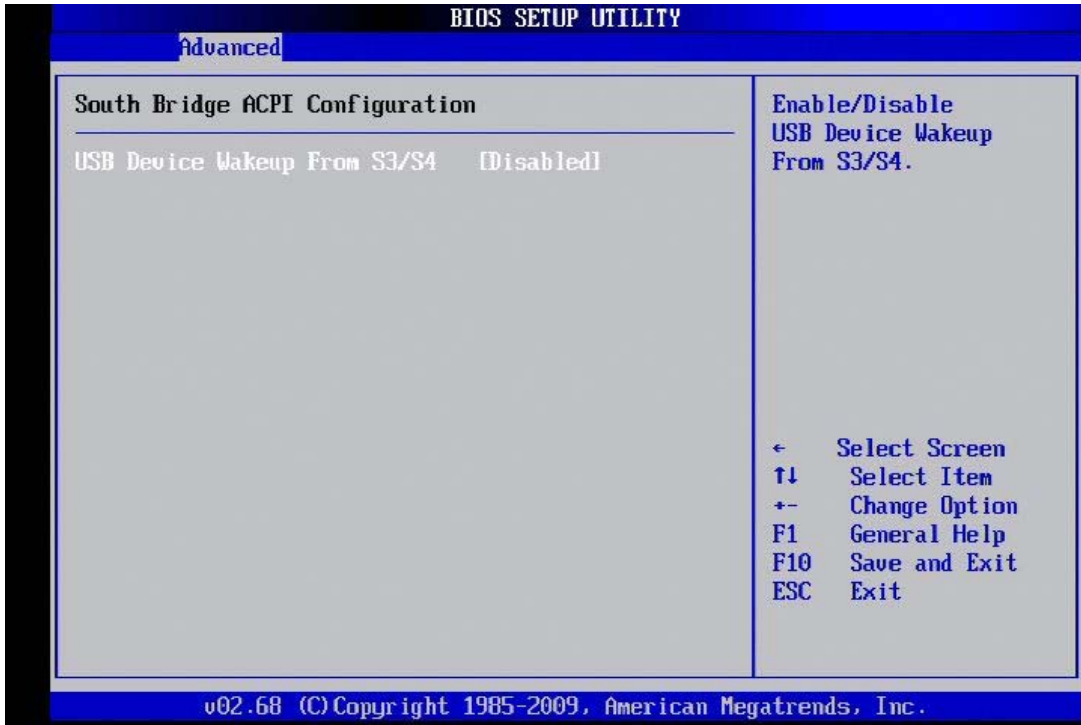

# User's Manual

## 3.3.6 AHCI Configuration

This sub menu is used to change the settings for the AHCI.

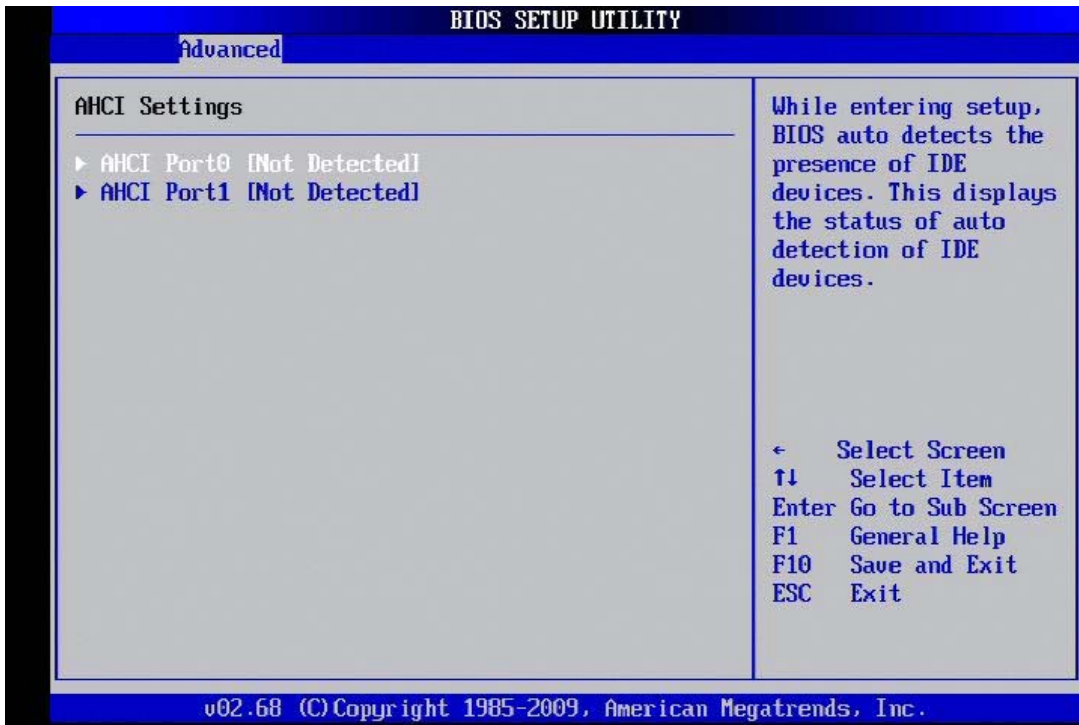

## AHCI Port0

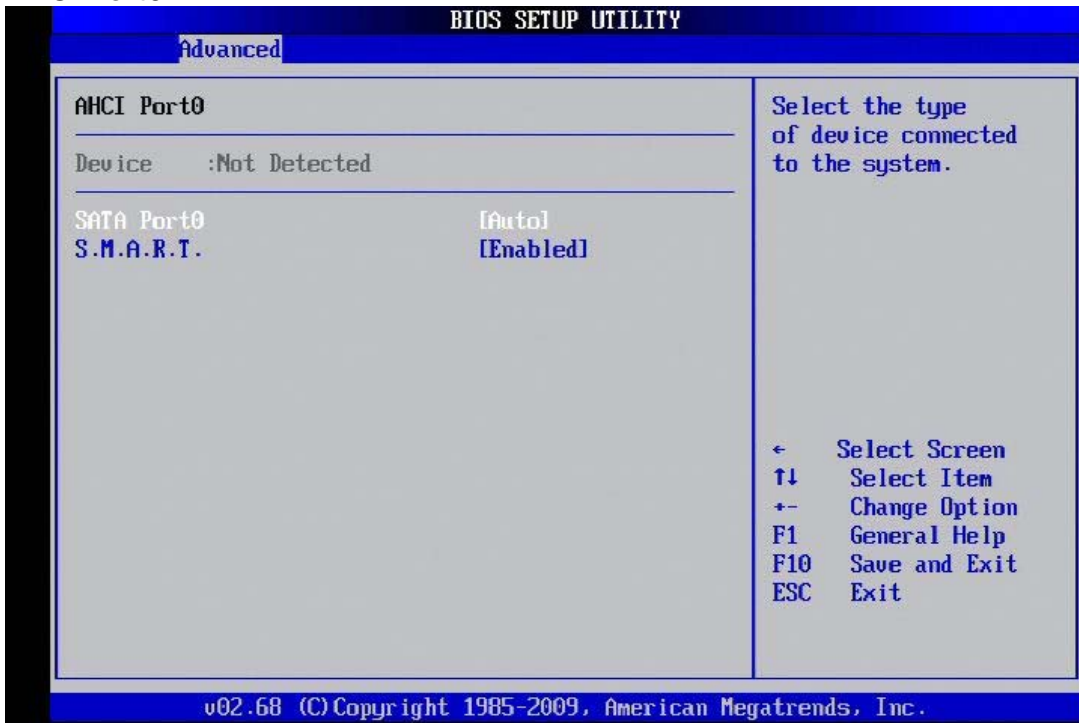



# User's Manual

## AHCI Port1

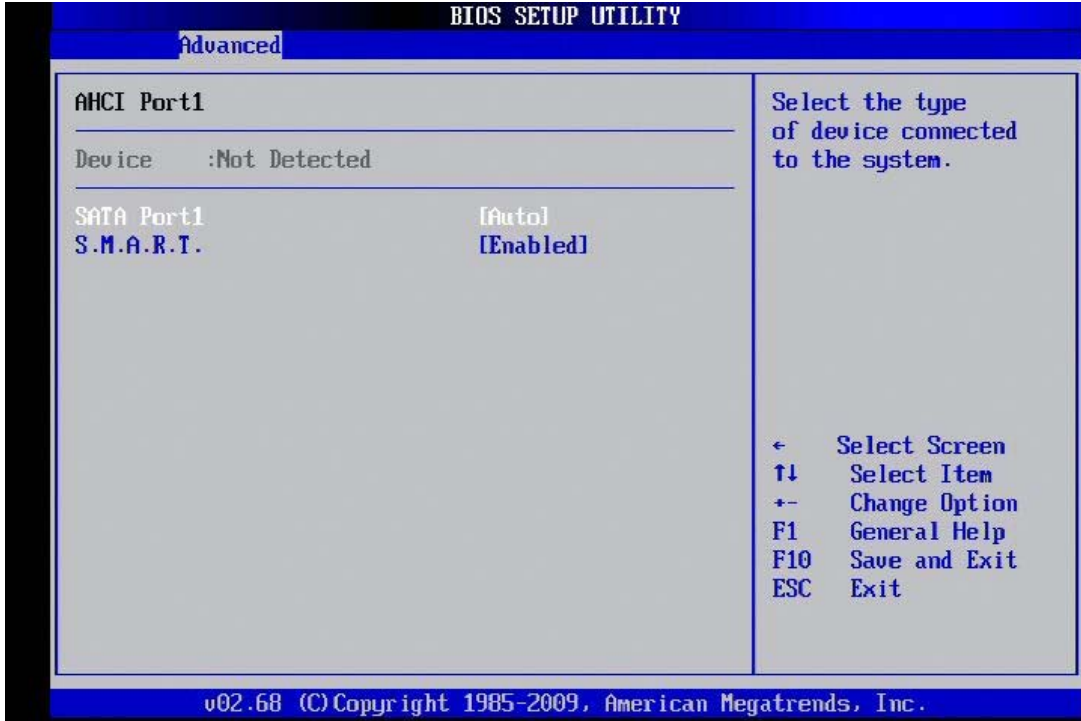

# User's Manual

## 3.3.7 ISA Configuration

This sub menu is used to change the settings for the ISA.

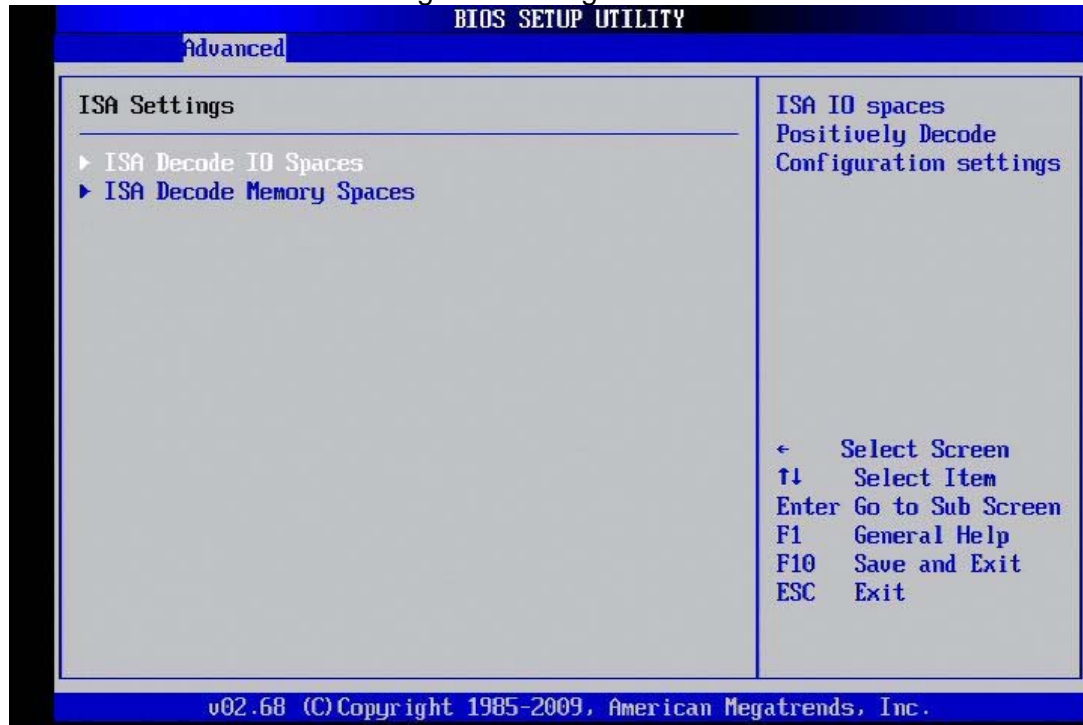

## ISA Decode IO Spaces



# User's Manual

## ISA Decode Memory Spaces

BIOS SETUP UTILITY

Advanced

ISA Decode Memory Spaces

Decode Memory Space 0	[Enabled]	Positively Decode Memory Space Window 0.
Memory Decoding Speed	[Medium Speed]	
Memory Decoding Base Addr.	[ D00]	
Memory Decoding Size	[ 64 KBI]	
Decode Memory Space 1	[Enabled]	
Memory Decoding Speed	[Medium Speed]	
Memory Decoding Base Addr.	[ 0]	
Memory Decoding Size	[ 32 KBI]	
Decode Memory Space 2	[Enabled]	
Memory Decoding Speed	[Medium Speed]	
Memory Decoding Base Addr.	[ 0]	
Memory Decoding Size	[ 32 KBI]	
Decode Memory Space 3	[Enabled]	
Memory Decoding Speed	[Medium Speed]	
Memory Decoding Base Addr.	[ 0]	
Memory Decoding Size	[ 32 KBI]	

← Select Screen  
↑↓ Select Item  
+- Change Option  
F1 General Help  
F10 Save and Exit  
ESC Exit

v02.68 (C) Copyright 1985-2009, American Megatrends, Inc.

## 3.3.8 USB Configuration

This sub menu allows you to change the USB-related features.



## 3.4 PCIPnP Menu

This PCIPnP menu items allow you to change the settings for the advanced PCI/PnP.

↓ Use the PCIPnP Setup option as follows:

1. Choose "PCIPnP" from the main menu. The following screen appears:

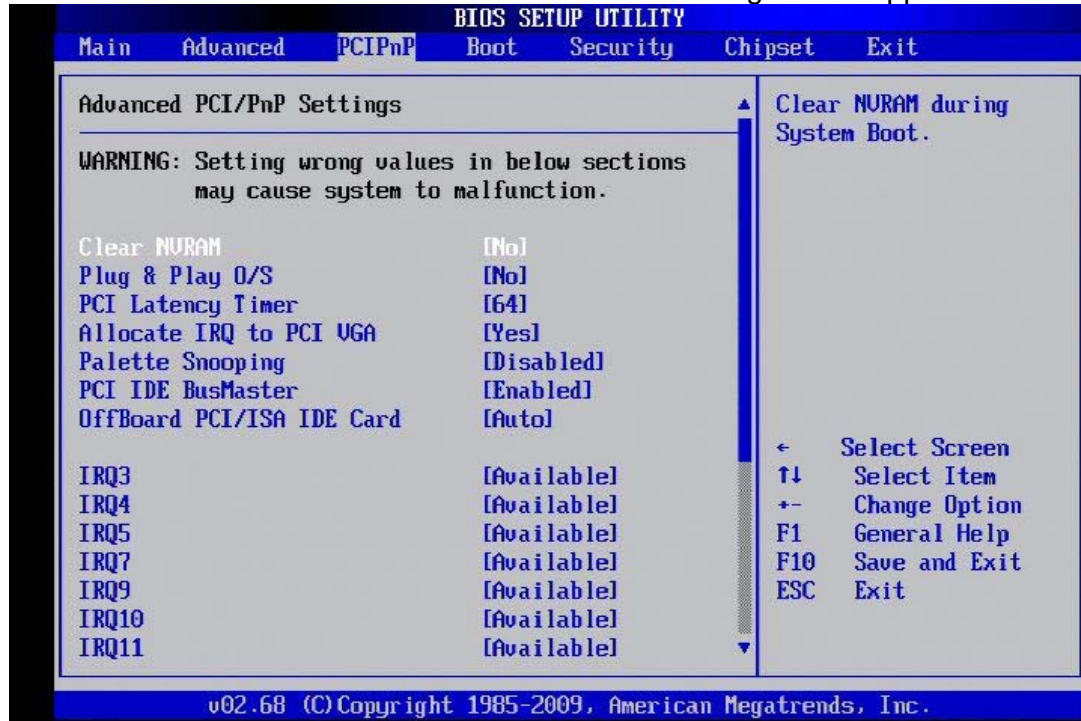

2. Use the arrow keys to move between items and to select values. Modify the selected fields using the PgUP/PgDN keys. Press the <F1> "Help" key for information on the available options:
3. After you have finished with the PCIPnP Setup, press the <ESC> key to return to the main menu.

### Clear NVRAM: [No]

This item allows you to clear the BIOS setting

### Plug & Play O/S: [No]

No: lets the BIOS configure all the devices in the system.

Yes: lets the OS configure Plug & Play devices not required for boot if your system has a Plug & Play operating system.

### PCI Latency Timer: [64]

This item allows you to select the value in units of PCI clocks for the PCI device latency timer register. This setting controls how many PCI clocks each PCI device can hold the bus before another PCI device takes over.

**Allocate IRQ to PCI VGA: [Yes]**

BIOS assigns an IRQ to PCI VGA card if the card requests for an IRQ.

**Palette Snooping: [Disabled]**

This item allows you to enable or disable the feature. When set to [Enabled], the palette snooping feature informs the PCI devices that an ISA graphics device is installed in the system so that the device can function correctly.

**PCI IDE BusMaster: [Enabled]**

This item allows you to enable or disable the feature.

Enable: BIOS uses PCI bus mastering for reading/writing to IDE devices.

**OffBoard PCI/ISA IDE Card: [Auto]**

This item allows you to configure the setting of OffBoard PCI/ISA IDE Card.

## 3.5 Boot Menu

↓ Use the **Boot Setup** option as follows:

1. Choose "Boot" from the main menu. The following screen appears:

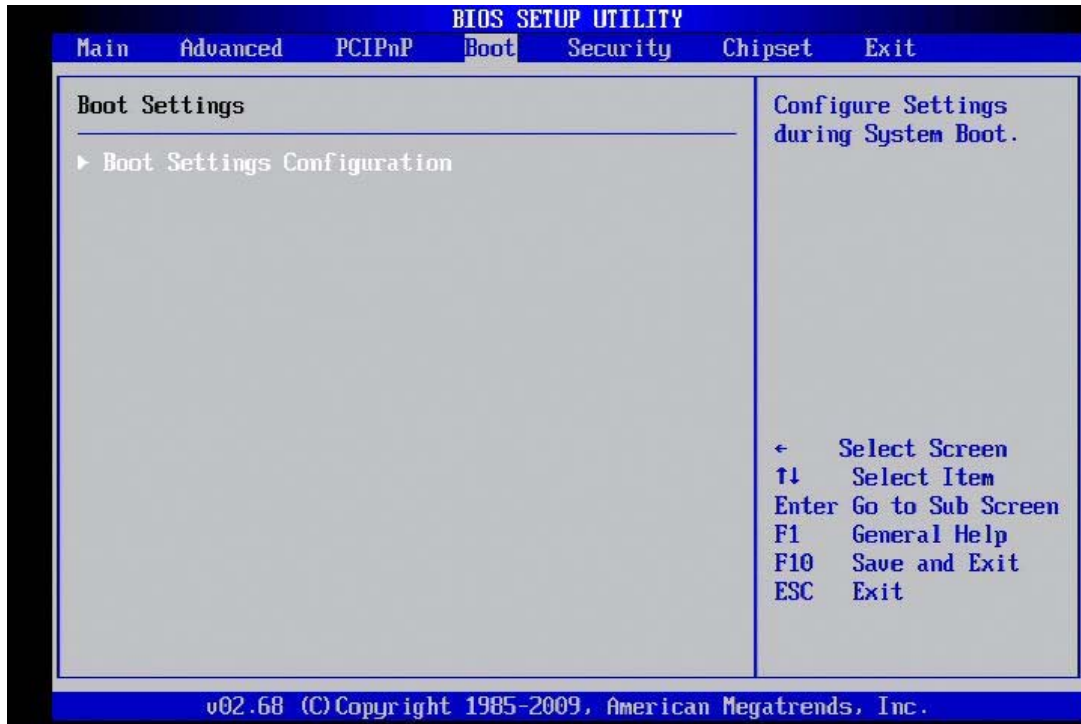

2. Move between items and select values by using the arrow keys. Modify the selected fields using the PnUP/PgDN Keys. For information on the various options, press <F1> key .
3. After you have finished with the Boot setup, press the <ESC> key to return to the main menu.

## 3.5.1 Boot Settings Configuration

This item is used to configure system boot setting with below sub menus:

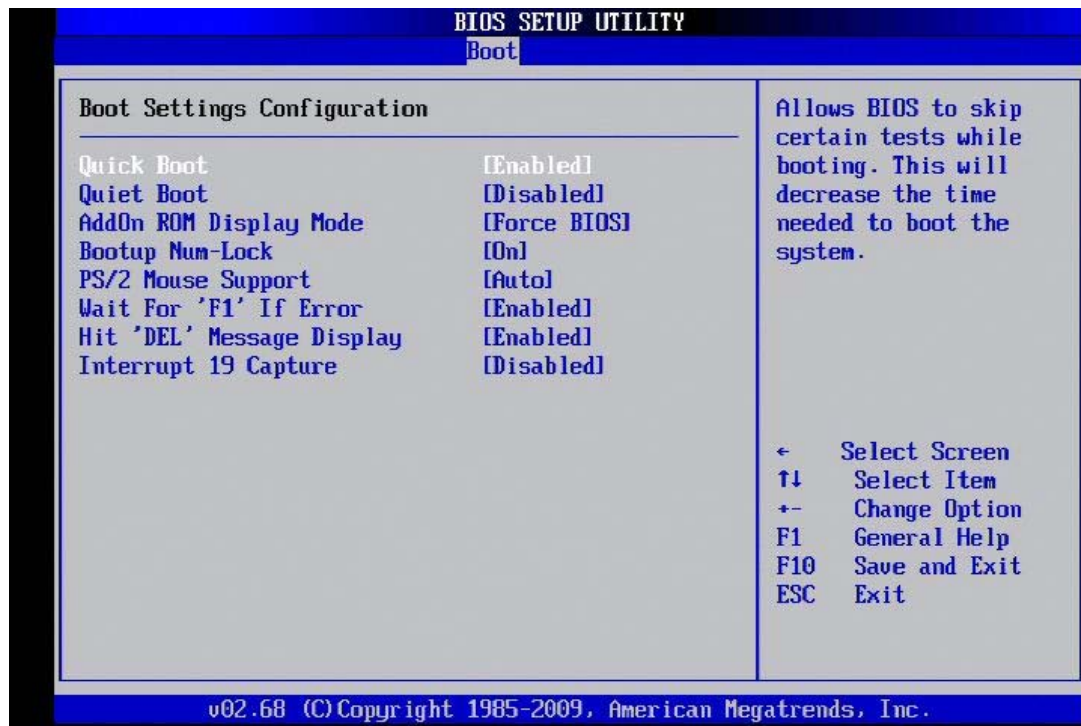

### Quick Boot: [Enabled]

This item allows BIOS to skip certain tests (POST, Power On Self Tests) while booting. This will decrease the time needed to boot the system.

### Quiet Boot: [Disabled]

This item allows you to enable or disable the full screen logo display feature. Disabled: displays normal POST messages.

### Bootup Num-Lock: [On]

Allows you to select the Power-on state for the Num-Lock.

### PS/2 Mouse Support: [Auto]

Select support for PS/2 Mouse.

### Wait for 'F1' If Error: [Enabled]

Wait for F1 key to be pressed if error occurs.

### Hit 'DEL' Message Display: [Enabled]

Displays "Press DEL to run Setup" in Post.

### Interrupt 19 Capture: [Disabled]

This item allows the option ROMs to trap Interrupt 19.



## 3.6 Security Menu

↓ Use the Security Setup option as follows:

1. Choose "Security" from the main menu. The following screen appears:

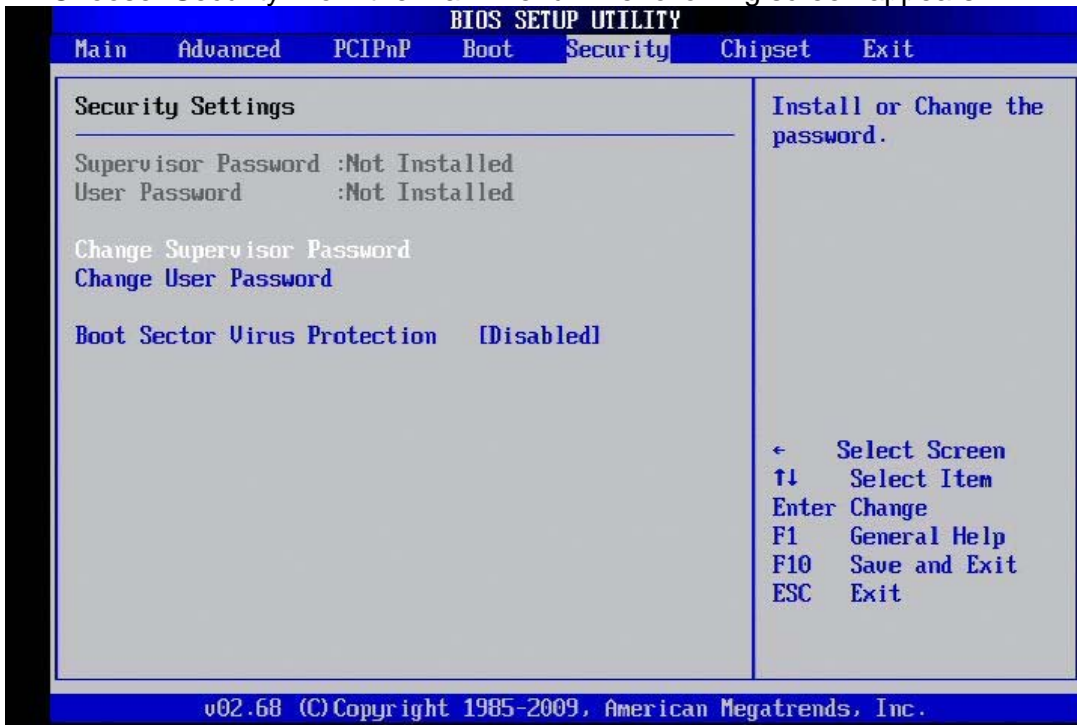

2. Move between items and select values by using the arrow keys. Modify the selected fields using the PgUP/PgDN keys. Please press the <F1> key for information on the various options.
3. After you have finished with the Security setup, press the <ESC> key to return to the main menu.

### Change Supervisor Password:

This item allows you to set or change the supervisor password. The Supervisor Password item on top of the screen shows the default Not Installed. After you have set a password, this item shows Installed.

### Change User Password:

This item allows you to set or change the user password. The User Password item on top of the screen shows the default Not Installed. After you have set a password, this item shows Installed.

### Clear User Password:

This item allows you to clear the user password.

### Boot Sector Virus Protection: [Disabled]

This item allows you to enable or disable the boot sector virus protection. If enabled, AMI BIOS will issue a warning when a virus or program attempts

to write to the hard disk's boot sector or attempts to execute disk format command.

## 3.7 Chipset Menu

↓ Use the Chipset Setup option as follows:

1. Choose "Chipset" from the main menu. The following screen appears.

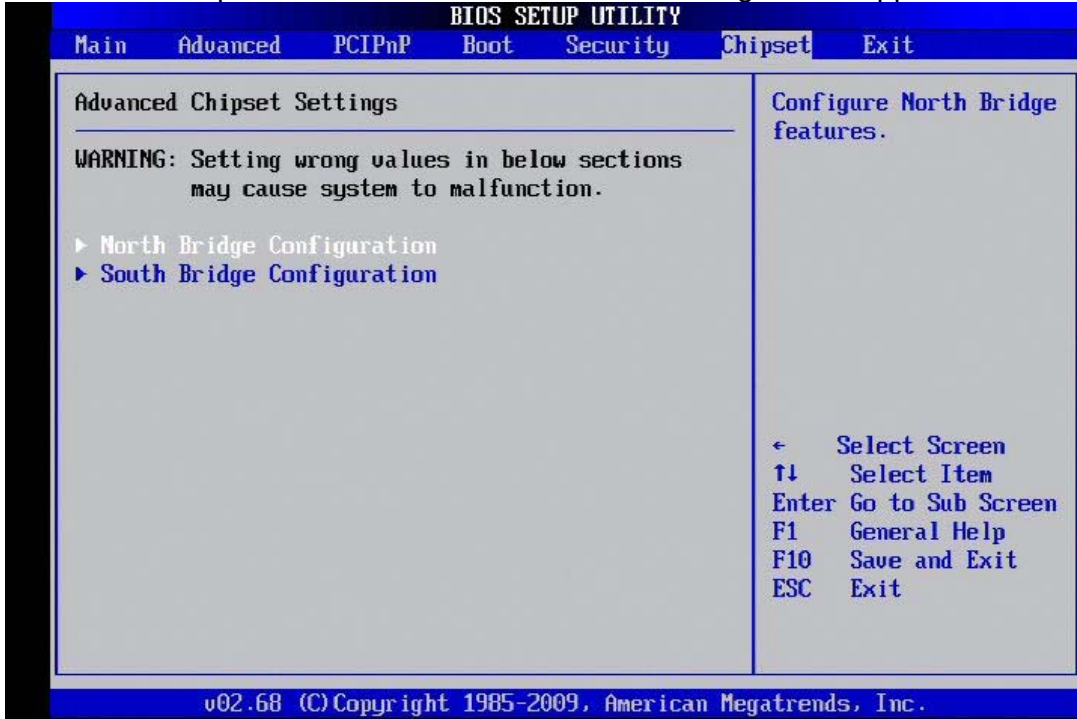

2. Move between items and select values by using the arrow keys. Modify the selected field the PgUP/PgDN keys. For information on the various options, press <F1> key.

After you have finished with the Chipset Setup, press the <ESC> key to return to the main menu.

## 3.7.1 North Bridge Configuration

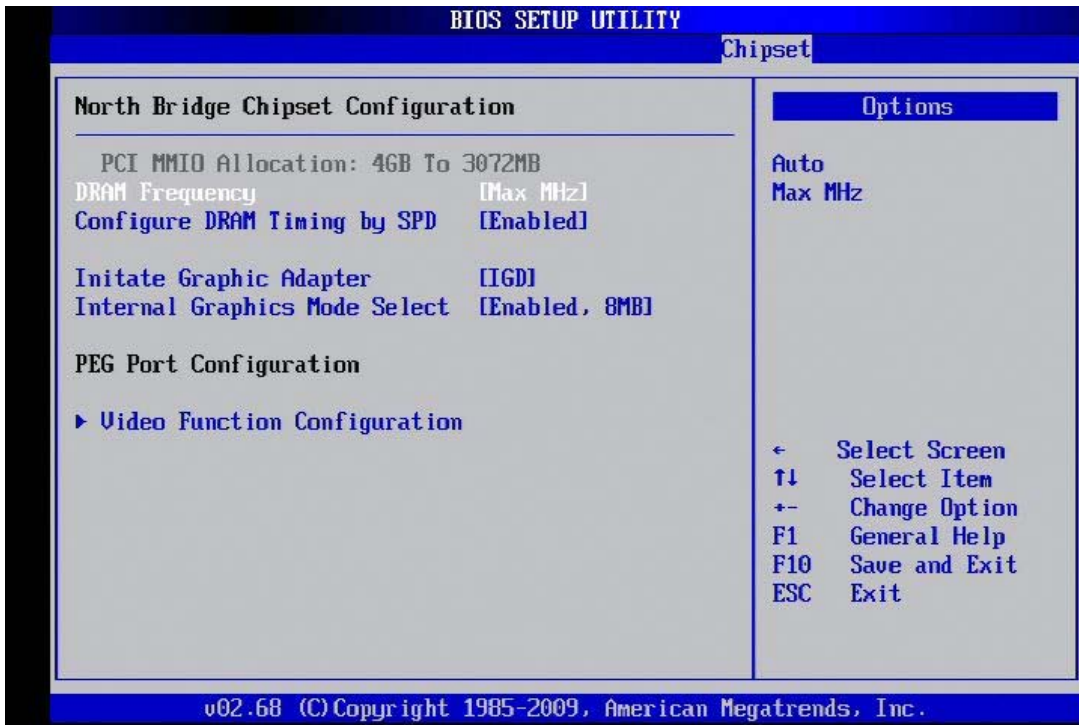

### **Initiate Graphic Adapter: [IGD]**

This item allows you to set the graphic adapter.

### **Internal Graphics Mode Select: [Enabled, 8MB]**

Select the amount of system memory used by the internal graphics device.

# User's Manual

## Video Function Configuration

The screenshot displays the BIOS SETUP UTILITY interface, specifically the Chipset menu. The main area is titled "Video Function Configuration" and lists several settings with their current values in brackets. To the right, there is an "Options" section with a legend for navigation keys.

Video Function Configuration		Options
DUMT Mode Select	[DUMT Mode]	Fixed Mode
DUMT/FIXED Memory	[256MB]	DUMT Mode
Boot Display Device	[VBIOS-Default]	
Flat Panel Type	[1366*768]	
Backlight Control Support	[VBIOS-Default]	
BIA Control	[VBIOS-Default]	
TU Standard	[VBIOS-Default]	
Spread Spectrum Clock	[Disabled]	

Key	Action
←	Select Screen
↑↓	Select Item
+ -	Change Option
F1	General Help
F10	Save and Exit
ESC	Exit

v02.68 (C) Copyright 1985-2009, American Megatrends, Inc.

## 3.7.2 South Bridge Configuration

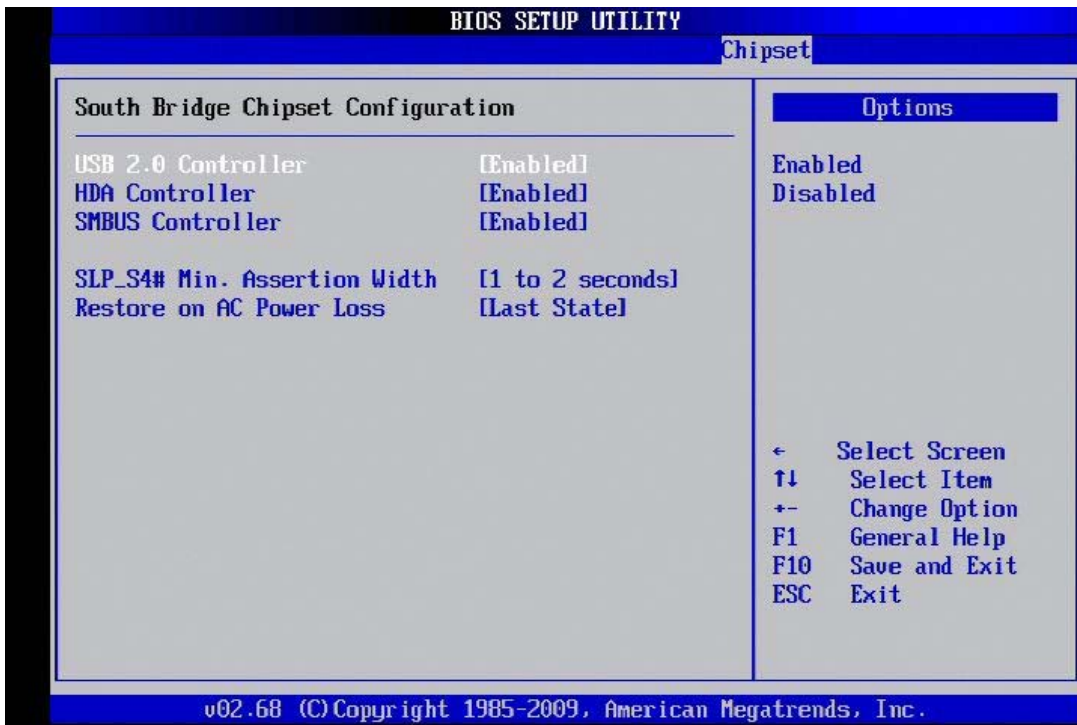

### **USB 2.0 Controller: [Enabled]**

This item allows you to enable or disable the USB 2.0 controller.

### **HAD Controller: [Enabled]**

This item allows you to enable or disable the HAD Controller.

### **SMBUS Controller: [Enabled]**

This item allows you to enable or disable the SMBUS Controller.

## 3.8 Exit

The item allows you to save or discard your changes to the BIOS items, and load the optimal defaults or failsafe defaults for the BIOS items.

↓ Use the Exit option as follows:

1. Choose "Exit" from the main menu, the following screen appears.

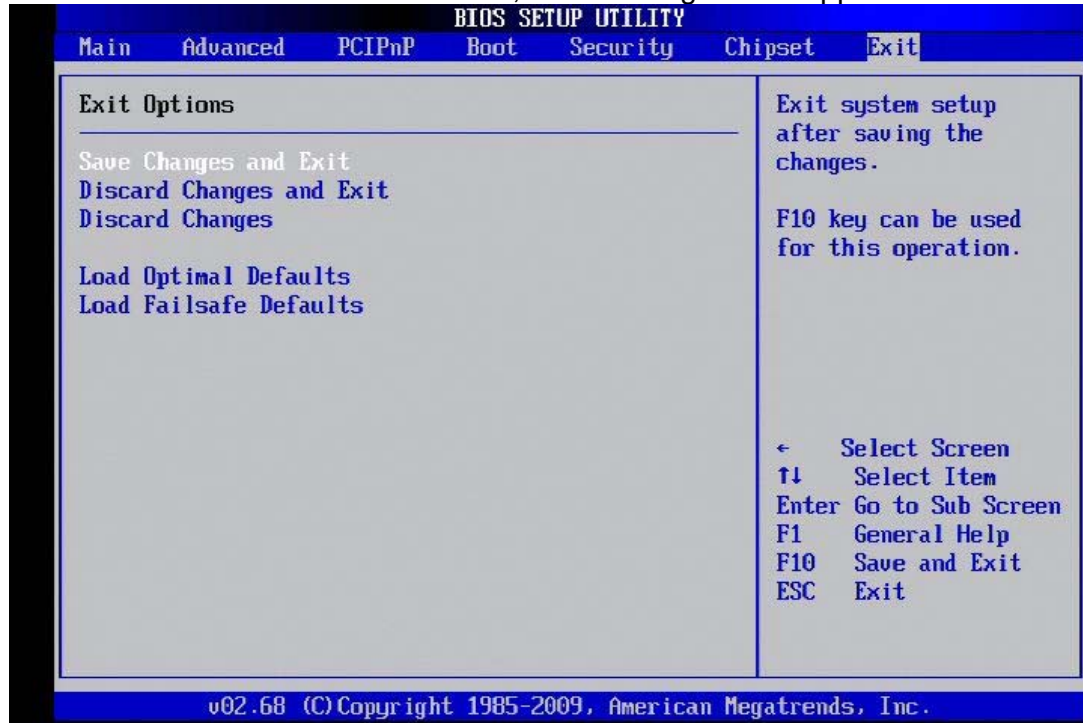

2. Move between items and select values by using the arrow keys. Modify the selected fields using the PgUP/PgDN keys. For information on the various options, please press <F1> key.
3. Please press the <ESC> key to return the main menu after finishing with the Exit Options.

### Save Changes and Exit:

Save changes of values to CMOS and exit the CMOS setup program. F10 key can be used for this operation.

### Discard Changes and Exit:

Discard all CMOS changes and exit the CMOS setup program. ESC key can be used for this operation.

### Discard Changes:

Discard all CMOS changes and load the previously saved values. F7 key can be used for this operation.

**Load Optimal Defaults:**

This item allows you to load optimal defaults for each of the parameters on the Setup menus, which will provide the best performance settings for your system. F9 key can be used for this operation.

**Load Failsafe Defaults:**

This item allows you to load failsafe defaults for each of the parameters on the Setup menus, which will provide the most stable performance settings. F8 key can be used for this operation.



[sales@win-ent.com](mailto:sales@win-ent.com) +1 (978) 688-2000