

Surface Mount Aluminum Electrolytic Capacitors NACH Series

FEATURES

- CYLINDRICAL V-CHIP CONSTRUCTION
- WIDE TEMPERATURE -40° ~+105°C
- LONG LIFE (+105°C, 2000 HOURS)
- 6.3 mm MAXIMUM HEIGHT
- DESIGNED FOR REFLOW SOLDERING

**RoHS
Compliant**
includes all homogeneous materials

*See Part Number System for Details

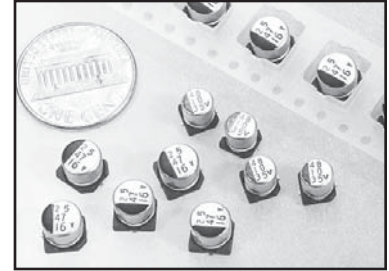

CHARACTERISTICS

Rated Voltage Range	4 ~ 50Vdc							
Rate Capacitance Range	0.1 ~ 220μF							
Operating Temp. Range	-40°C ~ +105°C							
Capacitance Tolerance	±20% (M)							
Max. Leakage Current After 2 Minutes @ 20°C	0.01CV or 3μA whichever is greater							
Working Voltage/Surge Voltage Max. Tan δ @ 120Hz/20°C	W.V. (Vdc)	4	6.3	10	16	25	35	50
	S.V. (Vdc)	5	8.0	13	20	32	44	63
	Dissipation Factor	0.50	0.30	0.22	0.16	0.14**	0.12	0.12
Low Temperature Stability Impedance Ratio @ 120Hz	Z-40°C/Z+20°C	7	4	3	2	2	2	2
	Z-55/Z+20°C	12	8	6	4	4	3	3
Load Life Test @ 105°C 2,000 Hours	Capacitance Change	Within ±25% of initial measured value						
	Tan δ	Less than 200% of specified value						
	Leakage Current	Less than specified value						

STANDARD VALUES AND CASE SIZES (mm)

Cap (μF)	Code	Working Voltage (Vdc)						
		4.0	6.3	10	16	25	35	50
0.1	R10	-	-	-	-	-	-	4x6.3
0.22	R22	-	-	-	-	-	-	4x6.3
0.33	R33	-	-	-	-	-	-	4x6.3
0.47	R47	-	-	-	-	-	-	4x6.3
1.0	1R0	-	-	-	-	-	-	4x6.3
2.2	2R2	-	-	-	-	-	-	4x6.3
3.3	3R3	-	-	-	-	-	-	4x6.3
4.7	4R7	-	-	-	-	4x6.3	-	5x6.3
10	100	-	-	-	4x6.3	-	5x6.3	6.3x6.3
22	220	-	4x6.3	-	5x6.3	-	6.3x6.3	-
33	330	-	4x6.3	5x6.3	-	6.3x6.3	-	-
47	470	4x6.3	5x6.3	-	6.3x6.3	-	-	-
100	101	5x6.3	6.3x6.3	-	--	-	-	-
220	221	6.3x6.3	-	-	-	-	-	-

PART NUMBER SYSTEM

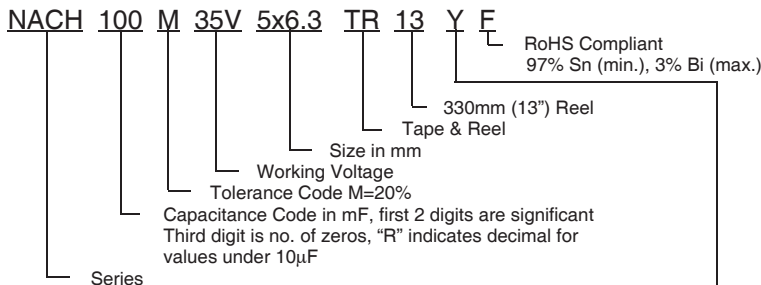

Optional: Suitable for automotive equipment, sourced to special production and inspection at TS-16949 certified production site

PRECAUTIONS

Please review the notes on correct use, safety and precautions found on pages T10 & T11 of NIC's Electrolytic Capacitor catalog.
Also found at www.niccomp.com/precautions
If in doubt or uncertainty, please review your specific application - process details with NIC's technical support personnel: tpmg@niccomp.com



Surface Mount Aluminum Electrolytic Capacitors NACH Series

STANDARD VALUES, CASE SIZES AND SPECIFICATIONS

NIC Part Number	Cap. (μF)	W.V. (Vdc)	Dissipation Factor (Tan δ)	Max. Ripple Current (mA) +105°C/120Hz	Maximum ESR (Ω) +20°C/120Hz	Load Life Hours @ +105°C
NACH470M4V4x6.3TR13F	47	4.0	0.50	34	17.7	2,000
NACH101M4V5x6.3TR13F	100		0.50	61	8.31	2,000
NACH221M4V6.3x6.3TR13F	220		0.50	82	3.77	2,000
NACH220M6.3V4x6.3TR13F	22	6.3	0.30	26	22.6	2,000
NACH330M6.3V4x6.3TR13F	33		0.30	29	15.1	2,000
NACH470M6.3V5x6.3TR13F	47		0.30	46	10.6	2,000
NACH101M6.3V6.3x6.3TR13F	100	10	0.30	71	4.98	2,000
NACH330M10V5x6.3TR13F	33		0.22	43	11.1	2,000
NACH100M16V4x6.3TR13F	10		16	0.16	28	26.6
NACH220M16V5x6.3TR13F	22	0.16		39	12.1	2,000
NACH470M16V6.3x6.3TR13F	47	0.16		70	5.66	2,000
NACH4R7M25V4x6.3TR13F	4.7	25	0.14	22	49.5	2,000
NACH330M25V6.3x6.3TR13F	33		0.14	65	7.05	2,000
NACH100M35V5x6.3TR13F	10	35	0.12	28	19.9	2,000
NACH220M35V6.3x6.3TR13F	22		0.12	55	9.05	2,000
NACHR10M50V4x6.3TR13F	0.1	50	0.12	1.0	1993	2,000
NACHR22M50V4x6.3TR13F	0.22		0.12	2.0	906	2,000
NACHR33M50V4x6.3TR13F	0.33		0.12	3.0	604	2,000
NACHR47M50V4x6.3TR13F	0.47		0.12	5.0	424	2,000
NACH1R0M50V4x6.3TR13F	1.0		0.12	10	199	2,000
NACH2R2M50V4x6.3TR13F	2.2		0.12	16	90.6	2,000
NACH3R3M50V4x6.3TR13F	3.3		0.12	16	60.4	2,000
NACH4R7M50V5x6.3TR13F	4.7		0.12	23	42.4	2,000
NACH100M50V6.3x6.3TR13F	10		0.12	35	19.9	2,000

For Automotive Equipment see part number system

RIPPLE CURRENT FREQUENCY CORRECTION FACTOR

Frequency Hz	50 < f < 100	100 < f < 1K	1K < f < 10K	10K < f < 100K
Correction Factor	0.8	1.0	1.3	1.5

DIMENSIONS (mm)

Case Size	Dφ ±0.5	L max.	A ±0.2	B ±0.2	I ±0.2	W	P ±0.2
4 x 6.3	4.0	6.3	4.3	4.3	1.8	0.5 ~ 0.8	1.0
5 x 6.3	5.0	6.3	5.3	5.3	2.2	0.5 ~ 0.8	1.5
6.3 x 6.3	6.3	6.3	6.6	6.6	2.5	0.5 ~ 0.8	2.2

RECOMMENDED LAND PATTERN DIMENSIONS (mm)

Case Size	a	b	c
4 φ	1.0	2.6	1.8
5 φ	1.4	3.0	1.8
6.3 φ	1.8	3.6	1.8

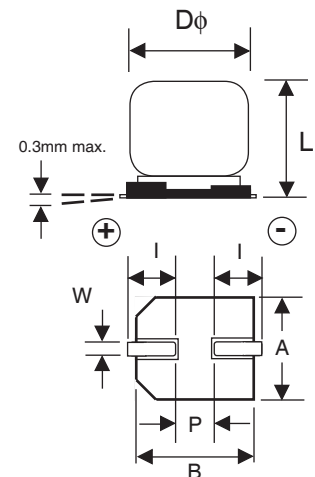
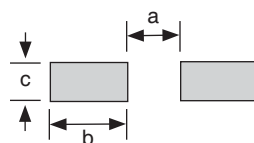

Review & Compare Reflow Soldering Heat Limits
V-chip SMT Aluminum Electrolytic Capacitors
www.niccomp.com/RSL



EMBOSED CARRIER DIMENSIONS (mm)

Case Size	A ± 0.5	B ± 0.5	C ± 0.3	D ± 0.1	P ± 0.1	T ± 0.2	t ± 0.2
4 x 6.3	4.7	4.7	12.0	5.5	8.0	6.4	0.6
5 x 6.3	5.7	5.7	12.0	5.5	12.0	6.4	0.6
6.x x 6.3	7.0	7.0	16.0	7.5	12.0	6.5	0.6

TAPING SPECIFICATIONS (mm)

- Both Leader and Trailer tape: Minimum 40mm (1.57") empty carrier tape pockets.
- Leader tape: Approximately 20cm of cover tape at leader.
- Connection: Maximum 3 connections (slices) per reel.

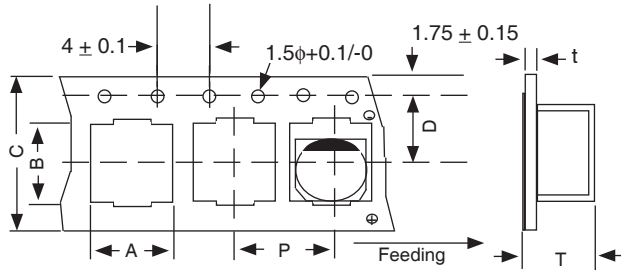

REEL DIMENSIONS AND QUANTITIES

Case Size	W ± 1.0	Reel Quantity 330mm	Reel Quantity 380mm
4 x 6.3	14	1,200	1,000
5 x 6.3	14	800	1,000
6.x x 6.3	18	800	1,000

